

**CAPACITOR SWITCHING TRANSIENT ANALYSIS ON  
A TRANSMISSION GRID SUBSTATION  
(CASE STUDY: THULHIRIYA GSS)**

Don Lishan Prasanga Munasinghe

(119131 H)



University of Moratuwa, Sri Lanka.  
Electronic Theses & Dissertations  
[www.lib.mrt.ac.lk](http://www.lib.mrt.ac.lk)

Dissertation submitted in partial fulfillment of the requirement for the  
Degree of Master of Science

Department of Electrical Engineering

University of Moratuwa  
Sri Lanka

June 2015

## DECLARATION

I declare that this is my own work and this dissertation does not incorporate without acknowledgement any material previously submitted for a Degree or Diploma in any other University or institute of higher learning and to the best of my knowledge and belief it does not contain any material previously published or written by another person except where the acknowledgement is made in the text.

Also, I hereby grant to University of Moratuwa the non-exclusive right to reproduce and distribute my dissertation, in whole or in part in print, electronic or other medium. I retain the right to use this content in whole or part in future works (such as articles or books).

Signature: \_\_\_\_\_

Date: \_\_\_\_\_



D.L.P. Munasinghe

University of Moratuwa, Sri Lanka.

Electronic Theses & Dissertations

[www.lib.mrt.ac.lk](http://www.lib.mrt.ac.lk)

The above candidate has carried out research for the Masters Dissertation under our supervision.

Signatures of the supervisors:

\_\_\_\_\_  
Dr. K.T.M.U. Hemapala

Date: \_\_\_\_\_

Dr. U.N. Gnanarathna  
(University of Manitoba – Canada)

## ACKNOWLEDGEMENT

I sincerely thank my supervisor, Dr. K.T.M.U. Hemapala for his great supervision and guidance offered for the successful completion of this study. I extend my sincere thanks to lecturers of Electrical Engineering Department, University of Moratuwa, who gave me the theoretical knowledge and the support during the study period to make the study practical and meaningful.

My special thanks go to Dr. U.N. Gnanarathna, University of Manitoba, Canada, who spent his valuable time to guide me and providing valuable information required for this study.

I am also grateful to Centralized section and Kandy region of Transmission Operation and maintenance branch and my colleagues in Ceylon Electricity Board, who supported and encourages me in numerous ways to successful completion of this study.



University of Moratuwa, Sri Lanka.  
Electronic Theses & Dissertations  
[www.lib.mrt.ac.lk](http://www.lib.mrt.ac.lk)

It is also with great pleasure that I remember the encouragement and support extended by the colleagues in the post graduate program and specially my parents and my wife. May be I could not have completed this research without their valuable support.

## ABSTRACT

The quality of electric power system has a great concern and also it has been a constant topic of study. A transient originated from capacitor bank switching are main reason which affects the power quality. The analysis, simulation and optimal use of capacitor banks under harmonic conditions are required in a power network to optimally locate and sizing of a capacitor bank. If the capacitor banks are not properly selected and placed in the power system they could amplify and propagate harmonics, deteriorate the power quality to unacceptable levels and the transients produce under different conditions will be negatively affected to the switchgears in the substation.

The breaker switched capacitor (BSC) banks are commonly used for power factor correction, reactive power requirement and voltage support by many utilities in the world. Ceylon electricity board (CEB) has also installed total of 370 Mvar capacitor banks island-wide in transmission grid substations (GSS) in 33 kV level.

The motivation for the study is the failure of 100 Mvar BSC banks installed at the Pannipitiya GSS after putting in to operations. After this incident the Thulhiriya GSS and Athurugitriya GSS BSC banks were switched off since they also came under same project with same equipment. In this study the Thulhiriya GSS was selected as the case study to analyze the switching transients of the 33 kV BSC banks to the system.



University of Moratuwa, Sri Lanka  
Electronic Theses & Dissertations  
www.lib.mrt.ac.lk

Data for the selected substation were recorded and analyzed and the selected substation was modeled using PSCAD simulation program to analyze the transients and harmonics. The objective of the study is to investigate the particular BSC bank is safe for operations without under utilizing by comparing the obtained simulated results with the standards and specifications, observe the switching transients and harmonics, introduce a safe region for closing of the BSC banks, introduce a proper sequence for closing of the BSC banks and introduce time delays for back to back switching of the BSC banks with minimum effect to the quality of the waveform.

The results obtained for the particular substation are expected to be extrapolated to a general concept to suit the whole substations in the CEB network.

## TABLE OF CONTENT

Declaration	i
Acknowledgment	ii
Abstract	iii
Table of Content	iv
List of Figures	vii
List of Tables	x
List of Abbreviations	xi
1. Introduction	1
1.1. Back ground	1
1.2. Motivation of the study and Objectives	2
1.3. Scope of work	2
2. Capacitor banks in power systems	3
2.1. Active, reactive, apparent and power triangle	3
2.2. Power factor correction	3
2.3. Capacitor size and location	6
2.4. Application standards	7
2.5. The capacitor unit	7
2.6. Fuse technologies	9
2.7. Different types of capacitor banks	10
2.8. Capacitor bank configurations	11
2.9. Capacitor bank installation	12
2.10. Controlling philosophy	14
2.11. Problems with the capacitor banks	15
2.12. Capacitor bank switching equipment	15
2.13. CEB capacitor bank specification	15
2.14. CEB capacitor bank network	16
3. Power quality issues	17
3.1. Power quality problems	17
3.2. Different abnormal conditions in the power system	18
4. The case study	20

4.1.	Failure of capacitor banks at Pannipitiya substation	20
4.2.	Thulhiriya substation details	20
4.3.	Capacitor controller at Thulhiriya substation	21
4.4.	Data collection	22
	4.4.1. Log Sheets	23
	4.4.2. Power Quality Analyzer (PQA)	25
4.5.	Power factor variation	27
4.6.	Mvar requirement	27
4.7.	Harmonics in the system	29
4.8.	Capacitor switching pattern in an average day	30
4.9.	CBT 400 Measurements	30
5.	Methodology	32
	5.1. PSCAD modeling and simulation tool	32
	5.2. Grid model	33
	5.3. Capacitor bank model	35
	5.4. Control panel	36
	5.5. Harmonic model	37
	5.6. Fast Fourier transform	38
	5.7. Model validation	38
	5.8. Measured parameter from the simulation	39
	5.9. Step by step simulation	40
6.	Results and analysis	41
	6.1. Separate witching of capacitor banks	41
	6.1.1. Capacitor bank No 01	41
	6.1.2. Capacitor bank No 02	43
	6.1.3. Switching with different 33kV loading	45
	6.2. Back to back switching	47
	6.2.1. Sequence Capacitor bank 01, 02	47
	6.2.2. Sequence Capacitor bank 02, 01	48
	6.3. Fast switching	51
	6.3.1. Sequence Capacitor bank 01, 02	51
	6.3.2. Sequence Capacitor bank 02, 01	52

6.3.3.	Switching with different 33kV loading	54
6.4.	Harmonics present in the system	55
6.5.	Harmonics and Total Harmonic Distortion	57
6.5.1.	After energizing capacitor bank 01	57
6.5.2.	After energizing capacitor bank 02	57
6.5.3.	After energizing both capacitor banks	58
6.6.	Summary of analysis and results (for the model)	59
7.	Conclusions and recommendations	62
	Reference List	65
Appendix 1	Single line diagram of Thulhiriya substation	67
Appendix 2	Technical Specification of 132 kV Areva Circuit Breaker	70
Appendix 3	Technical Specification of Alsthom power transformer	72
Appendix 4	132 kV conductor data sheet	75
Appendix 5	Manual of Joslyn Circuit Breaker	76
Appendix 6	Installation of capacitor bank at Thulhiriya GSS	84
Appendix 7	Technical Specification of Novar 300 Controller	85
Appendix 8	Waveforms obtained for model validation	88
Appendix 9	Simulated waveforms for capacitor bank one closing	89
Appendix 10	Simulated waveforms for capacitor bank two closing	92
Appendix 11	Switching of capacitor bank one for randomly selected loads at voltage peak	95
Appendix 12	Switching of capacitor bank two for randomly selected loads at voltage peak	98
Appendix 13	Fast switching of capacitor banks sequence of bank one to two with 1 ms delay time increasing	101
Appendix 14	Fast switching of capacitor banks sequence of bank two to one with 1 ms delay time increasing	103
Appendix 15	Fast switching for selected loading	105

## LIST OF FIGURES

Figure 2.1	The power triangle	3
Figure 2.2	Relationship of Capacitance, Reactance and working power	6
Figure 2.3	The capacitor unit and cross section	9
Figure 2.4	Fuse technologies	10
Figure 2.5	Multiple units Grounded single Wye	11
Figure 2.6	Multiple units in series phase to ground double Wye	11
Figure 2.7	Multiple units ungrounded single Wye	12
Figure 2.8	Multiple units ungrounded double Wye	12
Figure 2.9	Metal Enclosed types	13
Figure 2.10	Pad mounted	13
Figure 2.11	Stacked rack mounted	13
Figure 2.12	Pole mounted	14
Figure 3.1	Types of power disturbances	17
Figure 3.2	Switching Transient	18
Figure 4.1	Novar 300 Controllers	22
Figure 4.2	Novar 300 block Diagram	22
Figure 4.3	Mvar Requirement in Bus Section 01	23
Figure 4.4	Mvar Requirement in Bus Section 02	23
Figure 4.5	Power Factor variation in Bus Section 01	24
Figure 4.6	Power Factor variation in Bus Section 02	24
Figure 4.7	Set up of Power Quality Analyzer	25
Figure 4.8:	Voltage waveform	26
Figure 4.9	Current Waveform	26
Figure 4.10	Active power measurement	26
Figure 4.11	Power Factor Variation	27
Figure 4.12	Reactive Power Requirement	28
Figure 4.13	Harmonics in Current waveform	29
Figure 4.14	Harmonics in Voltage waveform	29
Figure 4.15	Switching pattern for Capacitor Banks at Thulhiriya GSS	30



Figure 4.16	Capacitor Breaker of bank one closing	31
Figure 4.17	Capacitor Breaker of bank one opening	31
Figure 4.18	Capacitor Breaker of bank one close opening	31
Figure 4.19	Capacitor Breaker of bank two closing	31
Figure 4.20	Capacitor Breaker of bank two opening	31
Figure 4.21	Capacitor Breaker of bank two close open	31
Figure 5.1	Typical working window of PSCAD software	33
Figure 5.2	Grid Model	34
Figure 5.3	Configuration of 132 kV incomers	34
Figure 5.4	Configuration of 132/ 33 kV transformer	35
Figure 5.5	Capacitor Bank 01	36
Figure 5.6	Capacitor Bank 02	36
Figure 5.7	Time Delay Blocks for switching	36
Figure 5.8	Control Panel of Circuit Breakers	37
Figure 5.9	Addition of Harmonics	37
Figure 5.10	Online Fast Fourier Transformer	38
Figure 6.1	Average loading configuration	41
Figure 6.2	Energizing of capacitor bank one at zero crossing	42
Figure 6.3	Energizing of capacitor bank one at voltage peak	42
Figure 6.4	Energizing of capacitor bank two at zero crossing	44
Figure 6.5	Energizing of capacitor bank two at voltage peak	44
Figure 6.6	Back to back switching sequence of capacitor bank one to two at zero crossing	47
Figure 6.7	Back to back switching sequence of capacitor bank one to two at voltage peak	48
Figure 6.8	Back to back switching sequence of capacitor bank two to one at zero crossing	49
Figure 6.9	Back to back switching sequence of capacitor bank two to one at voltage peak	50
Figure 6.10	Fast switching sequence of bank one to two at 3ms delay	51
Figure 6.11	Fast switching sequence of bank one to two at 10ms delay	52
Figure 6.12	Fast switching sequence of bank one to two at 17ms delay	52

Figure 6.13	Fast switching sequence of bank two to one at 12ms delay	53
Figure 6.14	Fast switching sequence of bank two to one at 38ms delay	53
Figure 6.15	Fast switching sequence of bank two to one at 12ms delay	54
Figure 6.16	Harmonic present in the system without capacitor banks	56
Figure 6.17	Harmonics in the system after switching capacitor bank one	57
Figure 6.18	Harmonics in the system after switching capacitor bank two	58
Figure 6.19	Harmonics in the system after switching both the capacitor banks	58
Figure 6.20	Implementation of RTU and PLC	63
Figure 6.21	Flow chart	64



University of Moratuwa, Sri Lanka.  
Electronic Theses & Dissertations  
[www.lib.mrt.ac.lk](http://www.lib.mrt.ac.lk)

## LIST OF TABLES

Table 2.1	Capacitor banks in Sri Lankan network	16
Table 4.1	Major equipment available at Thulhiriya Substation	21
Table 4.2	Unserved peak reactive power more than 5 Mvar in bus section one	28
Table 5.1	Comparison between measured and simulated data	39
Table 6.1	Voltage and current transient percentage for different switching time of bank one	43
Table 6.2	Voltage and current transient percentage for different switching time of bank two	44
Table 6.3	Randomly selected real loads for sensitivity analysis	45
Table 6.4	Voltage and current transient percentage for different switching time of bank one for randomly selected loads	46
Table 6.5	Voltage and current transient percentage for different switching time of bank two for randomly selected loads	46
Table 6.6	Minimum fast switching time delays to avoid transient	55
Table 6.7	Measured harmonics in the system	56
Table 6.8	Comparison of harmonic magnitudes with different capacitor energizing	59

## LIST OF ABBREVIATIONS

AIS	Air Insulated Switchgear
BSC	Breaker Switched Capacitor
CEB	Ceylon Electricity Board
CBT	Circuit Breaker Tester
EMTP	Electro Magnetic Transient Program
FFT	Fast Fourier Transform
GIS	Gas Insulated Switchgear
GUI	Graphical User Interphase
GSS	Grid Substation
IEEE	Institute of Electrical and Electronic Engineers
IEC	International Electrotechnical Commission
PCB	Poly Chlorinated Biphenyl
PQA	Power Quality Analyzer
PSCAD	Power System Computer Aided Design
PLC	Programmable Logic Controller
RTU	Remote Terminal Unit
RMS	Root Mean Square
THD	Total Harmonic Distortion



University of Moratuwa, Sri Lanka.  
Electronic Theses & Dissertations  
[www.lib.mrt.ac.lk](http://www.lib.mrt.ac.lk)

# 1 Introduction

## 1.1 Back Ground

Most of the apparatus used in the power system requires active power as well as certain amount of reactive power (VAR loads). Magnetic fields of motors/transformers maintained by reactive current, reactors, florescent lamps, and all inductive circuits requires certain amount of reactive power. The series inductance of transmission lines consumes reactive power. Compensation devices are used for offset reactive loads, they should be capable of generating reactive power. In power systems, the following devices are used to supply reactive power.

- Capacitors
- Synchronous condensers
- Conventional generators
- Static VAR compensators

From the above devices, power capacitors are the most commonly used device in the power network since they are comparatively economical and easy to install. Since the reactive power occupies a proportion of available transmission capacity and increases the system losses, it is important to make the distance between the compensating device and the apparatus to be compensated as short as possible. Also shunt capacitor banks help to reduce the losses in the transmission network and improve the system performance.

Shunt capacitors can be introduced in end customer premises, distribution network as well as transmission grid substations. For end customer, shunt capacitors are used as power factor correction device which helps to reduce demand and to avoid penalties from the utility. For distribution network and transmission network, they are used to reduce line losses and hence increase the line capacities and improve the bus voltage. If shunt capacitor banks are not properly selected and placed in the power system, they could amplify and propagate the harmonics, deteriorate the power quality to unacceptable level and the transients produced under different conditions will be negatively affected to switchgears in a Grid Substation (GSS) [4]. Therefore analysis, simulation and optimal use of capacitor banks under harmonic conditions are required in a power network to optimally locate and sizing of a capacitor bank.

A huge amount of money is invested in the power sector for constructing Grid Substations [4]. The invested amount for the power capacitor bank is a high portion of the total amount invested for a GSS. Therefore placing and sizing of a capacitor bank is vital in a grid substation to have reliable, efficient operation and optimal utilization of capacitor banks. Wrongly located and sized capacitor banks will negatively affect to major switchgears in a GSS.

## **1.2 Motivation of the study and Objectives**

Main objective of this study is to analyze the effect of switching of the BSC banks to the power quality and also to identify solutions for existing power quality issues with capacitor bank energizing.

100Mvar installed at Pannipitya substation in Sri Lanka which is owned by Ceylon Electricity Board (CEB) was failed after putting into commercial operation. Because of that the 10 Mvar capacitor bank installed at Thulhiriya substation and 20 Mvar capacitor bank installed at Athurugiriya substation were switched off and kept de energized even without any failure since all the three capacitor banks came to Sri Lankan network under same project with same equipment. This results in under utilization of available resources with an existing requirement. This scenario made the motivation for this study.



University of Moratuwa, Sri Lanka  
Electronic Theses & Dissertations  
[www.lib.mrt.ac.lk](http://www.lib.mrt.ac.lk)

## **1.3 Scope of work**

The study is mainly based on a selected Grid Substation in Sri Lanka's power network which is the Thulhiriya Grid Substation (GSS) as a case study. The study includes following steps.

- Analyze the present need of capacitor banks for the selected substation by collecting data through data logger and the log sheet data available at the substation
- Collecting the major equipment data in the substation and model the selected substation using the PSCAD simulation software
- Run the modeled simulation for transients and harmonics in various scenarios and loadings
- Analyze the obtained results for the selected substation and identify solutions for the existing power quality issues with the capacitor banks

## 2 Capacitor banks in power systems

### 2.1 Active, reactive, apparent power and power triangle

Electrical systems are made up of three basic types of loads namely resistive, inductive and capacitive. The industrial loads of the electrical system are highly inductive, which means that they require an electromagnetic field to operate. Magnetic fields of motors and transformers are maintained by reactive current. Reactors, florescent lamps, and all inductive circuits require certain amount of reactive power. Not only those loads the series inductance of transmission lines consumes reactive power. For inductive loads to operate requires real and reactive power to provide the electromagnetic field.

Three types of power are available at the power systems namely active, reactive and apparent power [6].

Active power (KW) is Working Power (also called Actual Power Real Power) which is the power that actually powers the equipment and performs useful work.

Reactive Power (KVAR) is the power that magnetic equipment (transformer, motor and relay) needs to produce the magnetizing flux.

Apparent Power (KVA) is the "vectorial summation" of KVAR and KW.

The power triangle shown in the figure 1.1 illustrates the relationship between three quantities [6].

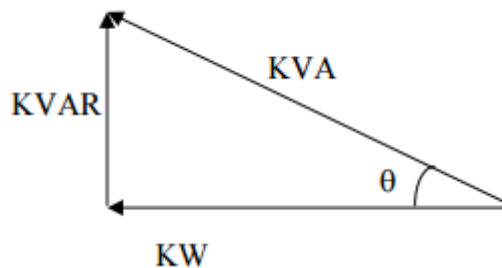

Figure 2.1: The power triangle

### 2.2 Power factor correction

Power factor is the ratio of active power and reactive power.

$$\text{P.F.} = \frac{\text{KW}}{\text{KVA}}$$

Power factor is related to power flow in electrical systems and measures how effectively an electric power system is being used. In order to efficiently use a power system we want power factor to be closer to 1.0 as possible, which implies that the flow of reactive power should be as kept to a minimum. Maintaining a high power factor is a key to obtaining the best possible economic advantage for both utilities and industrial end users [6].

Operating a power system at low power factor is a concern for both the electrical utility and the industry. The major cause of a poor power factor in a system is due to motors, which are inductive loads. Reduced system voltage often result when an electrical utility distribution system operates at a lower power factor. Low voltage results in dimming of lights and sluggish motor operation. In addition it increases the current flow in systems, which may damage or reduce the life of the equipment. It is in the best interest of both the electrical utility and industrial customers to maintain a high power factor. Operating the power system at a high power factor allows the system to maximize the capacity of the system by maximizing the delivery of the real power. Commercial and industrial customers avoid utility charges by operating at an acceptable power factor.

By improving the power factor following advantages can be achieved [6].

- Industrial and commercial customers can avoid power factor penalty charges by reducing the peak KW billing demand. Inductive loads, which require reactive power, caused low power factor. This increase in required reactive power causes an increase in required apparent power, which is what the utility is supplying. So a facility's low power factor causes the utility to have to increase its generation and transmission capacity in order to handle this extra demand. By raising the power factor, the usage of KVAR is less. This results in less KW, which equates to a savings from the utility.
- Utilities usually charge customers an additional fee when their power factor is less than certain power factor value. Thus the additional fee can be avoided by increasing the power factor.
- By adding capacitors to the system, the power factor is improved and the KW capacity of the system is increased. Low power factor causes power system



losses in the distribution system. By improving the power factor, these losses can be reduced. With lower system losses, additional loads can be added to the system.

- The efficiency of the power system is increased because real power flow is maximized and reactive power flow is minimized.
- Uncorrected power factor causes power system losses in the distribution system. As power losses increase, system may experience voltage drops. Excessive voltage drops can cause overheating and premature failure of motors and other inductive equipment. So, by raising the power factor, the voltage drops along the feeder cables can be minimized and avoid related problems. Motors will run cooler and be more efficient, with a slight increase in capacity and starting torque.

Sources of Reactive Power (inductive loads) such as transformers, induction motors, induction generators, high intensity discharge (HID) lighting decrease power factor. Similarly, consumers of Reactive Power such as Capacitors, Synchronous generators, Synchronous motors increase power factor. These are called reactive power compensation devices. And it is very much important to make the distance between the compensating device and the apparatus to be compensated as short as possible since the reactive power occupies a proportion of available transmission capacity and increases the system losses. And also the use of compensation devices will help to reduce the losses in the transmission network and improve the system performance.

The above said consumers of reactive power can be therefore used as compensation devices and increase power factor. Following are the ways for increase power factor

- Power capacitors are the most common device used as compensation devices. Installing capacitors decreases the magnitude of reactive power, thus increasing the power factor. Reactive power, caused by inductive loads, always acts at a 90-degree angle to active power [6].

Capacitors store reactive power and release energy opposing the reactive energy caused by the inductor. The presence of both a capacitor and inductor in the same circuit results in the continuous alternating transfer of energy

between the two. Thus, when the circuit is balanced, all the energy released by the inductor is absorbed by the capacitor.

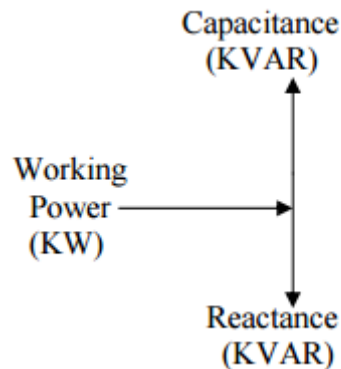

Figure 2.2: Relationship of Capacitance, Reactance and working power

- Low power factor is caused by induction motors as well as running induction motors lightly loaded. Thus operation of idling or lightly loaded motors should be minimized.
- Avoiding operation of equipment above its rated voltage.
- Replacing standard motors as they burn out with energy-efficient motors. Even with energy efficient motors, power factor is significantly affected by variations in load. A motor must be operated near its rated load in order to obtain the benefits.

### 2.3 Capacitor size and location

Shunt capacitors can be introduced to distribution network or to transmission grid substations as compensation devices. The capacitors should be optimally located to minimize the losses along the distribution feeders and also to maintain the voltage profile within acceptable limit. The amounts of benefit that can be obtained by placing the capacitors depend mainly on how the capacitors are placed on the power system. If shunt capacitor banks are not properly selected and placed in the power system they could amplify and propagate the harmonics, deteriorate the power quality to unacceptable level and the transients produced under different conditions will be negatively affected to switchgears in a Grid Substation [4]. Thus analysis,

simulation and optimal use of capacitor banks under harmonic conditions are required in a power network to optimally locate and sizing of a capacitor bank.

## 2.4 Application standards

### 2.4.1 IEC60871-1: 1997 [7]

Under the routine test capacitor should withstand ac test voltage of 2.15 times rated r.m.s. voltage

Long duration power frequency voltages are,

100% of r.m.s. voltage for continuous operation at power frequency

110% of r.m.s. voltage for 12hr in every 24hr

115% of r.m.s. voltage for 30 min in every 24hr

120% of r.m.s. voltage for 5 min

130% of r.m.s. voltage for 1 min

### 2.4.2 IEEE 18-2002 [8]

Capacitors shall be capable of continuous operation provided that none of the following limitations are exceeded.

110% of the rated r.m.s. voltage 36.30 kV

120% of rated peak voltage 56.00 kV

135% of nominal r.m.s current based on rated kvar and rated voltage,

For 5Mvar banks 118.09 A

For 20Mvar banks 472.38 A

Capacitors shall be capable of withstanding switching transients having crest voltage upto two times

Reactive power manufacturing tolerance of up to 115% of rated reactive power.

## 2.5 The capacitor unit

Capacitor Banks consist of individual capacitor units where such a unit is a combination of shunt or series set of capacitor elements. Depending on the bank size, those units are again connected in series or parallel to give the required size. In medium and high voltage levels, sizing of the capacitors in parallel combinations in

banks generally has to consider the discharge energy through a shorted parallel capacitor in the same group. Earlier generation capacitor units were manufactured using very refined kraft paper with a PCB (Poly Chlorinated Biphenyl) impregnate. The kraft paper had many non-uniformities or flaws. Several layers of paper were used between the foil layers to avoid weak spots in the design. With this design, the stress levels were low but the dielectric losses were higher than that of today's capacitor can designs. High dielectric losses resulted in high hot spot temperatures. High temperatures accelerate deterioration of the capacitor dielectric strength. Failure of the dielectric material resulted in continued arcing, charring, and gas generation that swelled the capacitor cans and eventually ruptured the cases.

Today's capacitor units are built with polypropylene film (instead of kraft paper) and dielectric fluids with electrical characteristics superior to those of PCB. The polypropylene film is very thin, pure, and uniform, with exceptionally few design flaws. This latest design only requires two to three layers of film. While this increases the stress levels, it reduces the dielectric losses which results in low hot spot temperatures. As a result of these changes, today's capacitor units do not age quickly. Swelling or case rupture is now very rare. Because film layers are thin and of high quality, element failures do not cause arcing and charring. Instead, the foil welds together. Capacitor units for power system applications are built with dielectric polypropylene film, aluminum foil and impregnate. Thin layers of dielectric film are wound between the aluminum foils, which act as the electrode.

Capacitor unit made up of individual capacitor elements, arranged in parallel which is called a group of elements. Several groups of elements are connected in series to make the capacitor unit. All these arrangements are enclosed in a steel case. The internal discharge device is to reduce the residual voltage of the unit to less than 50 V within specified time duration. Two bushings are connected to the unit to take the output. Following figure shows capacitor unit with a cross section.



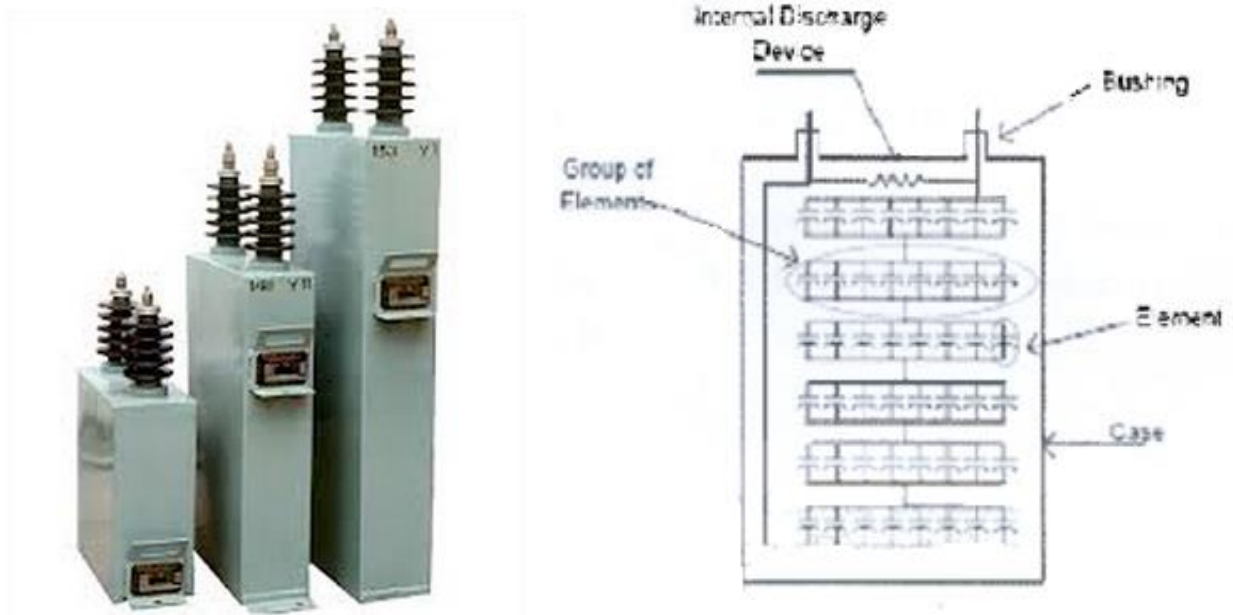

Figure 2.3: The capacitor unit and cross section [5]

## 2.6 Fuse technologies

Capacitor units are available with fusing technology to protect the unit. Three types of units are available as internally fused where the individual element is protected, externally fused where the unit as a whole is protected and fuseless units.

The current limiting fuses are used in internally fused capacitors. One fuse is connected in series with each element within the capacitor unit. They are designed and coordinated to isolate internal faults at the element level and allow continued operation of the remaining elements of that capacitor unit. This results in a very small part of the capacitor being disconnected, with the capacitor unit and the bank remaining in service. The fundamental concept is that by dividing a large system into small, individually protected elements, overall reliability is greatly enhanced. Advantages include higher reliability, less space, lower installation and maintenance costs and fewer live parts.

In the externally fused concept each unit has its own fuse for disconnecting a failed capacitor unit from the bank. Once a capacitor unit is removed, an overvoltage on the remaining parallel capacitors results. This overvoltage must either be limited to a maximum value of 110% voltage or the bank must be tripped offline. Although the

external fuses provide a visual indication of a failure, banks tend to occupy more substation space, are more expensive, have many live parts subject to possible damage by animals and have higher installation and maintenance costs.

In the fuseless design, the capacitor units are connected in series between phase and neutral to form a bank. When one capacitor element fails, the failed element will be welded and the remaining elements will be in service. The voltage across the failed element will be then shared by the other elements series within the same group [9].

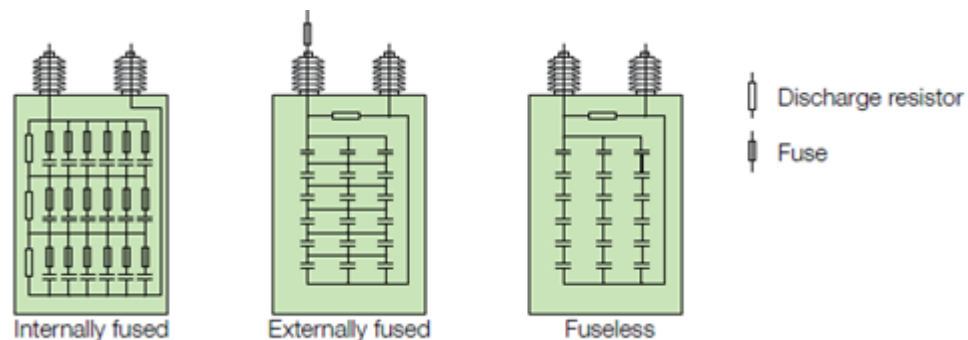

Figure 2.4: Fuse technologies

## 2.7 Different types of capacitor banks

Two types of capacitor banks are available in the present power networks namely fixed and switched capacitor banks. Fixed capacitor banks are those that always connected to the power system via a disconnecting device. The purpose of the disconnecting device is to disconnect the capacitor bank for maintenance. The fixed capacitors must be carefully designed and caution must be taken to ensure that the power factor should not go leading during light load conditions.

Switched capacitor banks are those that connected to the power system via a disconnecting device and a circuit breaker. Thus the switched capacitor banks are connected to the system if the requirement arises. Therefore they are not connected to the system all the time. These capacitor banks are referred as breaker switched capacitor (BSC) banks. These types of capacitor banks are connected to the system with if particular criteria reach a preset level. An automatic switch control is available to check the criteria with preset level. The following criteria can be checked to switch the capacitor banks.

- Power factor correction
- Reactive power requirement

- Voltage control
- Time control

## 2.8 Capacitor bank configurations

Present power system is having following capacitor bank configurations [5].

- Multiple units Grounded single Wye connected banks

This configuration composed of series and parallel connected capacitor units per phase as shown in the figure 2.5 and also low impedance path to ground is available at the star point which would provide protection for lightning surges and also provides low impedance path for high frequencies thus acting as a filter.

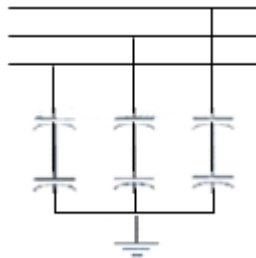

Figure 2.5: Multiple units Grounded single Wye

- Multiple units in series phase to ground double Wye

If the capacitor bank is too large the bank is two why sections as in the figure 2.6. This is also having a low impedance path to ground is available at the star point which would provide protection for lightning surges and also provides low impedance path for high frequencies thus acting as a filter.

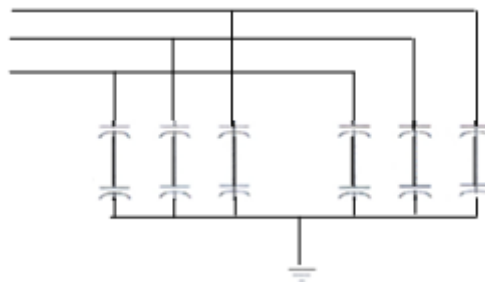

Figure 2.6: Multiple units in series phase to ground double Wye

- Multiple units ungrounded single Wye

This configuration is as similar to the multiple units Grounded single Wye connected banks without a low impedance path to ground as in the figure 2.7. Since the ground

connection is not available this configuration does not permit zero sequence currents, third harmonic currents and during a system ground fault a large capacitor discharge current can be occurred.

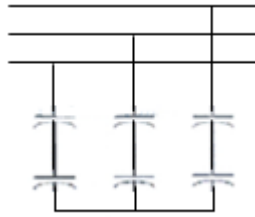

Figure 2.7: Multiple units ungrounded single Wye

- Multiple units ungrounded double wye

This configuration is same as the multiple units ungrounded single wye but with double wye sections as in the figure 2.8. The characteristics of this configuration are same as multiple units ungrounded single configuration.

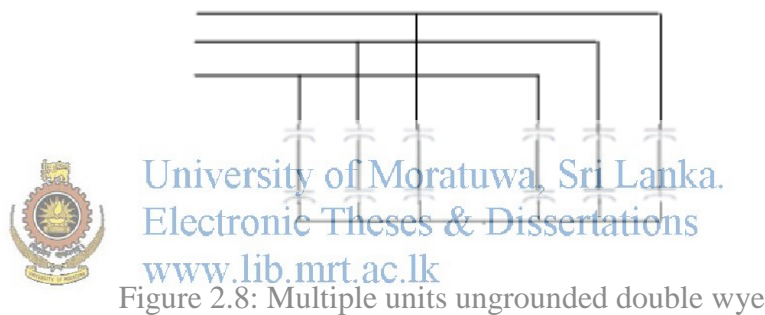

Figure 2.8: Multiple units ungrounded double wye

## 2.9 Capacitor bank installation

**2.9.1 Metal Enclosed types** - these types of capacitors are specially design for indoor installation. These capacitors are factory assembled and tested hence easy installation (Figure 2.9).

**2.9.2 Pad mounted** - Pad mounted capacitor banks are also enclosed in a metal enclosure and therefore fence is not needed. They are installed in places where public can easily reach. These are also factory assembled and tested hence easy installation. These types of capacitor banks are high cost and available up to certain voltage levels (Figure 2.10).

**2.9.3 Stacked rack mounted** - Stacked rack mounted capacitor banks are used in utility substations. All the equipment is in open space and therefore easily expandable and replaceable (Figure 2.11).



**2.9.4 Pole mounted** - The pole mounted capacitor banks are mainly used in distribution networks. These banks are available as smaller banks and in small voltage levels. The space requirement is very low in these types of banks (Figure 2.12).



Figure 2.9: Metal Enclosed types



University of Moratuwa, Sri Lanka.  
Electronic Theses & Dissertations  
[www.lib.mrt.ac.lk](http://www.lib.mrt.ac.lk)



Figure 2.10: Pad mounted



Figure 2.11: Stacked rack mounted



Figure 2.12: Pole mounted

### 2.10 Controlling philosophy

The switching of capacitor banks to the power system is done by considering one parameter or several parameters. The parameter for the same is decided by considering the local requirement of the utility. The parameters used for the switching are Voltage, var, power factor, time etc. Considering above parameters for switching the capacitor banks, there are two concepts of control philosophies.

1. Single variable switching: considers only one measuring parameter.
2. Multi variable and Boolean switching: In this case, multiple parameters are measured and the decision for switching is done depending on the optimal situation considering all parameters.

Voltage – this is used to regulate the voltage profiles on the bus on which the capacitors are connected to.

var – this adds a fixed amount of leading var to the system regardless of other conditions, and loss reduction depends only on reactive current. If the var requirement in the system reaches more than the capacitor bank capacity the capacitor bank will be automatically switched.

Power factor –capacitor banks are connected to the system based on the power factor. A preset value is defined in the controller and if the power factor of the system is less than the preset value then the capacitor banks are switched to the system. More banks are switched to the system until the power factor is corrected to the preset value.

Time – the capacitor banks can be switched to the system based on timing. So that one can define time periods to switch the capacitor banks and disconnect the capacitor banks based on the load characteristics. Thus this does not need any current or voltage transformer input.

### **2.11 Problems with the capacitor banks**

Despite the significant benefits that can be realized using capacitors for power factor correction, there are a number of power quality related concerns that should be considered before capacitors are installed. A well designed capacitor bank application should not have an adverse effect on end user equipment or on power quality. One of the more common power quality problems for consumers are transient voltages in the system that result from capacitor bank switching and, to a lesser extent, harmonic distortion once the capacitor is energized. The energizing transient, a power quality issue, is important because it is one of the most frequent system switching operations. These switching transients have the ability to adversely affect industrial customer's power electronic and non-linear loads.

### **2.12 Capacitor bank switching equipment**

Devices available for transient over voltage control attempt to minimize the transient over voltage or over current. Some of the techniques used for switched capacitor banks are pre-insertion resistors, pre-insertion inductors, fixed inductors, MOV arresters, series inrush-current-limiting reactors, dividing the capacitor bank into smaller size banks, avoiding the application of capacitors at multi-voltage levels to eliminate the possibilities of secondary resonance and to time the switching device to close at the best possible time which is the voltage across the switch is zero.

### **2.13 CEB capacitor bank specification**

All the capacitor banks are breaker switched capacitor banks which are shunt connected to the power system. The configuration is ungrounded double star connection. The capacitor banks are typically 5 Mvar providing 5 Mvar steps.

When installing capacitor banks the banks are connected to the 33kV bus sections symmetrically. This means in substations capacitor banks are installed to each and every bus section with same capacity. Selection of the location and the capacity of the capacitor banks are done by V, MW, and Mvar profile.

All most all the capacitor banks are equipped with bank feeder and a filter feeder.

However there are banks without those reactors as well. The banks with detuning reactor are called as the filter banks because they are meant for eliminating the switching inrush, reduce resonance effects and to filter several harmonics in the system loads. The other banks are sometimes having inrush limiting reactors and sometimes there are no such reactors [10].

#### 2.14 CEB capacitor bank network

For power factor correction and to cater the Mvar requirement breaker switched capacitor (BSC) banks are installed at Grid Substations at CEB power network. The existing installed BSC banks at substations and their capacity is shown in the table 2.1. All the banks are connected as ungrounded double star connection and all the capacitor banks in CEB network are connected to the 33kV load bus in the relevant grid substation and there are no capacitor banks at the transmission level. The reason for this is due to lower costs at low voltage levels than at higher voltage levels.

Table 2.1: Capacitor banks in Sri Lankan network

No	Location	Capacity (Mvar)
1	Galle (SVC)	20
2	Anuradhapura	20
3	Habarana	10
4	Kotugoda	50
5	Kiribathkumbura	20
6	Kurunagala	10
7	Matugama	20
8	Panadura	20
9	Puttalama	20
10	Pannipitiya	100
11	Athurugiriya	20
12	Thulhiriya	10
13	Ampara	30
14	Pallekele	20
	<b>Total</b>	<b>370</b>

### 3 Power quality issues

#### 3.1 Power quality problems

A well designed capacitor bank should not have an adverse effect on switchgears, end user equipment or on power quality. The quality of electric power has been a constant topic of study, mainly because poor power quality can lead to economic losses, especially in industrial processes, due to loss of production. Due to increasing installations of power electronics based equipment, the power system disturbances has become a common phenomenon. Power system disturbances are shown in the figure 3.1 [11].

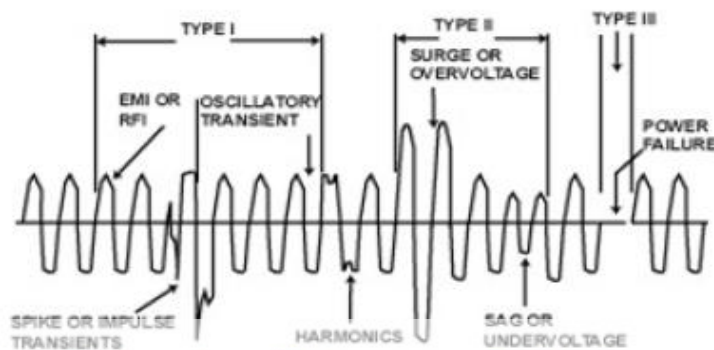

University of Moratuwa, Sri Lanka.  
Electronic Theses & Dissertations  
[www.lib.mrt.ac.lk](http://www.lib.mrt.ac.lk)

**3.1.1 A switching transient:** A transient is an immediate drop in system voltage, followed by a fast recovery (overshoot) and finally an oscillating transient voltage on the 50Hz waveform. The energizing transient is very important because it is one of the most frequent operations. Transient over voltage can happen due to lightning strikes, short circuits, equipment failures and capacitor switching etc. However, the transient occur can propagate in either directions of distribution feeder or transferred through capacitive/inductor couplings to the other voltage levels [11].

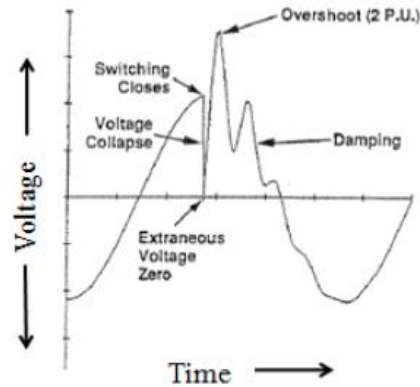

Figure 3.2: Switching Transient

**3.1.2 Harmonics:** Waveforms except the power frequency waveform are referred to as harmonics. Harmonic distortion of the voltage and current in an industrial facility is caused by the operation of nonlinear loads and devices on the power system. Harmonic distortion can be transferred to the utility power system where its disturbance of the sinusoidal waveform is commonly referred to as noise. Power electronics is the major source of harmonic distortion. However, apart from power electronic devices there are other sources of harmonic distortion such as arcing devices and equipment with saturable ferromagnetic cores. These loads draw non-sinusoidal currents, which in turn react with system impedance and produce voltage distortion. Application of capacitor banks can create series or parallel resonance, which magnifies the problem of harmonic distortion. If the resonant frequency is near one of the harmonic currents produced by the non-linear loads, a high-voltage distortion can take place. Overheating of power equipments & cables is another serious issue with the presence of the harmonics [11].

### 3.2 Different abnormal conditions in the power system

Power quality issues can be occurred with introduction with power equipment to the system and also with natural faults. Those abnormal conditions can be listed as follows [5],

- Normal switching of capacitor banks
- Fast switching of capacitor banks
- Switching of 33kV loads to the system

- Disconnection of loaded distribution feeder from the system
- Failure of capacitor units
- Unbalance faults in the system
- Balance faults in the system
- Lightning strokes
- Earth Faults



University of Moratuwa, Sri Lanka.  
Electronic Theses & Dissertations  
[www.lib.mrt.ac.lk](http://www.lib.mrt.ac.lk)

## **4 The case study**

### **4.1 Failure of capacitor banks at Pannipitiya substation**

During year 2000 it was identified that the low power factor of the Colombo power system as a serious problem to keep the operating voltage of the 132 kV in national grid. Not only in Colombo but also studies reveals that to boost the voltage and the power factor capacitor banks should be installed at Pannipitiya, Athurugiriya and Thulhiriya Substation. So as a result of that, under the transmission and Substation development project - 2, 100 Mvar capacitor bank was installed at Pannipitiya GSS, 20 Mvar capacitor bank was installed at Athurugiriya and 10 Mvar capacitor bank was installed at Thulhiriya GSS. However the 33 kV 100 Mvar shunt breaker switched capacitor bank installed at Pannipitiya substation was failed after putting into commercial operation. With that the capacitor banks installed at Athurugiriya and Thulhiriya substations were also switched off since they were also installed from the same project with same equipment [12]. However the studies revealed that the cause for the Pannipitiya capacitor bank failure is due to manual switching of entire 100 Mvar within 3 min and thus creating excessive voltage rise within short period of time.



University of Moratuwa, Sri Lanka.  
Electronic Theses & Dissertations  
www.lib.mut.ac.lk

The motivation for this study is the switched off capacitor banks due to the Pannipitiya capacitor banks failure. So as a case study Thulhiriya substation and the capacitor bank are selected.

### **4.2 Thulhiriya substation details**

Thulhiriya Substation is a 132/ 33 kV switching station which is fed by two number of 132 kV incomers from Polpitiya/ Athurugiriya 132 kV line. The substation is equipped with three numbers of 31.5 MVA transformers and 10 number of 33 kV feeder bays. Two number of capacitor banks are available each of size 5 Mvar bank feeder and filter feeder. 132 kV side of the substation is AIS (Air Insulated Switchgear) while 33 kV side of the substation is a GIS (Gas Insulated Switchgear). The major equipment available at the substation with their make is listed in the table 4.1 and the single line diagram is shown in Appendix 01.



Table 4.1: Major equipment available at Thulhiriya Substation

Equipment	Manufacture
Transformer (132/ 33 kV)	Alsthom
Circuit Breaker (132 kV)	Areva
Isolator (132 kV)	Alsthom
Surge Arrestor (132 kV)	Alsthom
GIS (33 kV)	Alsthom
Capacitor Bank (33 kV)	Cooper power system
Reactor	Trench
Capacitor switching circuit breaker	Joslyn
Capacitor bank Controller	Novar
Capacitor bank protection relay	Trench
132 kV protection relays	ABB

Technical specifications of 132 kV circuit breakers, 132/ 33 kV transformers, 132 kV conductor data sheet, manual of capacitor circuit breaker and installation of capacitor bank at Thulhiriya GSS are collected (Appendix 2, 3, 4, 5 and 6 respectively) and are used to obtain required data during the modeling of the substation.

### 4.3 Capacitor controller at Thulhiriya substation

The Novar 300 controller is the controller available at Thulhiriya substation for the switching of capacitor banks. The technical specification of the controller is attached as Appendix 7. The controller has following features

- Continuously measuring the system's kvar component and then switching the optimum quantity of capacitor compensation in, or out, to achieve the desired power factor
- Auto/Manual controller
- Can be varied
  - the time interval of steps
  - sequence of stages

- The limits which determines the number of steps taken in the sequence selected



Figure 4.1: Novar 300 Controller

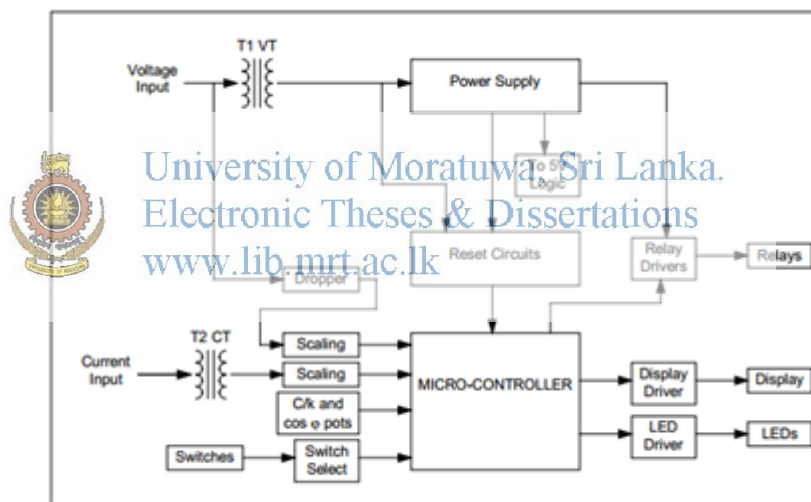

Figure 4.2: Novar 300 block Diagram

#### 4.4 Data collection

Measurement data were collected for the selected substation to sense the actual need of capacitor banks, to obtain the loading pattern of the GSS and to obtain the available harmonics in the power system.

Following two methods were used to collect the substation measurement data

- Log sheets
- Power quality analyzer

#### 4.4.1 Log sheets

Log sheet was obtained from the substation for an average day (17<sup>th</sup> September 2013) where the loading was average and all the bays and equipment are energized. The 33 kV bus section was opened on the particular day to find out the actual Mvar requirement of both the bus sections. Mvar variation of bus section 1 & 2 and the power factor variation of bus section 1 & 2 are plotted and shown in the figure 4.4, 4.5, 4.6 & 4.7 respectively.

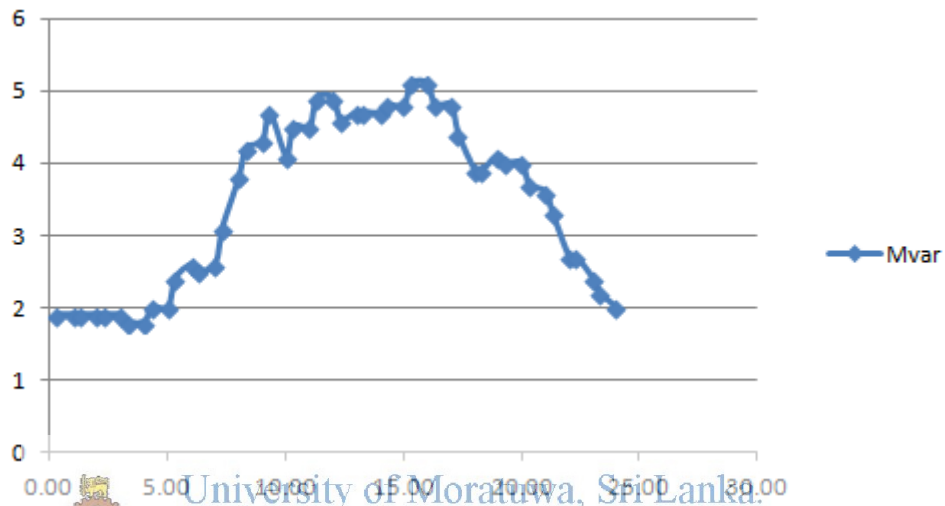

Figure 4.3: Mvar Requirement in Bus Section 01

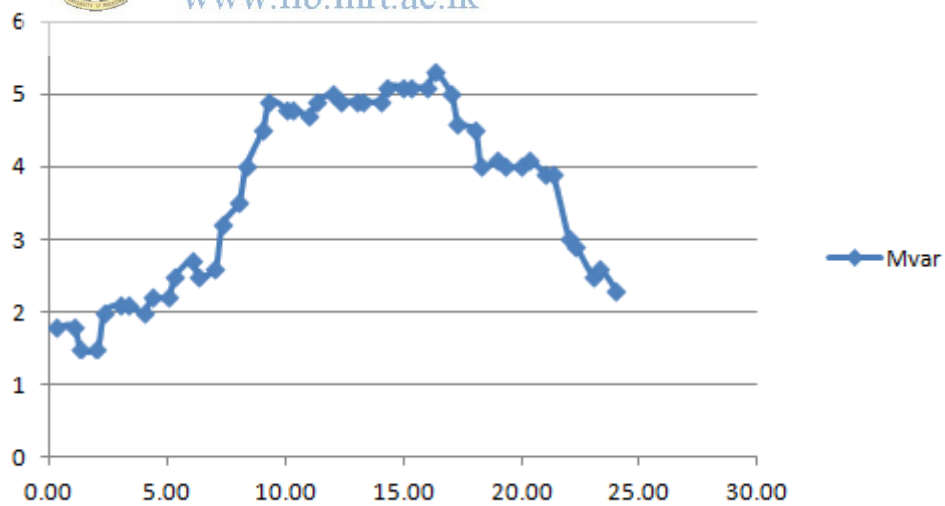

Figure 4.4: Mvar Requirement in Bus Section 02

Obtained results from the log sheets reveals that both the bus sections maximum Mvar requirement is more than 5 Mvar around 15 hrs.

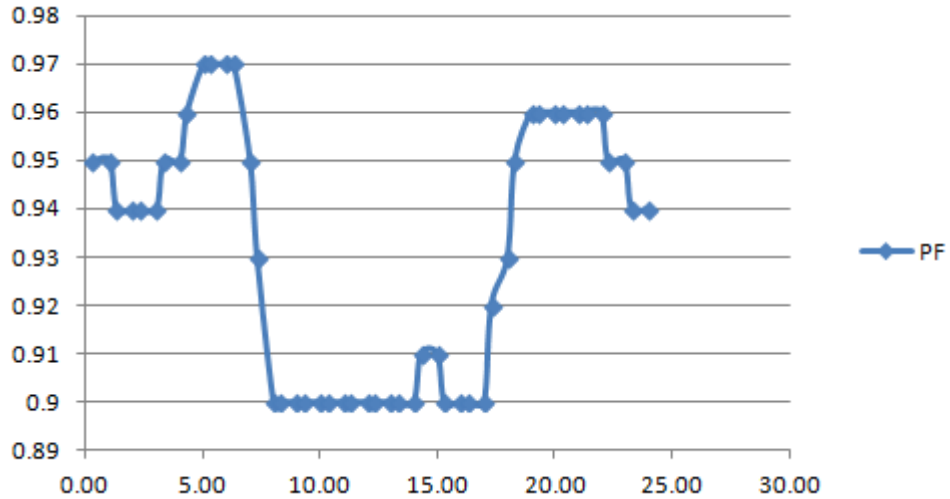

Figure 4.5: Power Factor variation in Bus Section 01

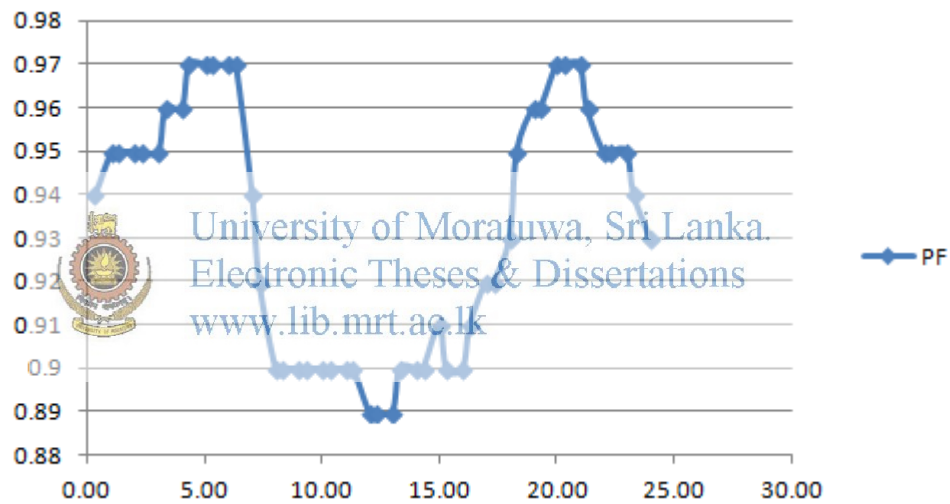

Figure 4.6: Power Factor variation in Bus Section 02

Obtained results from the log sheets shows that power factor of bus section one varies from 0.9 to 0.97 and power factor of bus section 2 varies from 0.89 to 0.97. However the log sheet data may not be accurate since they are taken by Control room operators from analogue meters.

#### 4.4.2 Power Quality Analyzer (PQA)

Without rely much on the log sheets available at the substation the power quality analyzer (Figure 4.7) is put up for three days. Power quality analyzer (LEM QWAVE PREMIUM) is an online data logger which can be fed three phase inputs and available with four current and voltage channels for inputs.



University of Moratuwa, Sri Lanka  
Electronic Theses & Dissertations  
[www.lib.mrt.ac.lk](http://www.lib.mrt.ac.lk)

PQA is connected to the 33 kV side of the bus section one to obtain the measurement for three days from 17<sup>th</sup> October 2013 to 19<sup>th</sup> October 2013. 33kV voltage, transformer 33 kV load, active power, reactive power, power factor, harmonics in the current waveform and harmonics in the voltage waveform are measured.

Figure 4.8 shows the obtained rms voltage of the 33 kV bus section one. The figure shows the line to earth voltage measurement. Figure 4.9 shows the current measurement in the transformer one 33kV side. Figure 4.10 shows the active power variation of the bus section one. The graph is plotted for all the three phases active power requirement and the total active power requirement. It shows regular daily pattern with two peaks. One peak can be observed around 6 hr which is in the morning peak and the other peak can be observed around 18 hr which is in the night peak.

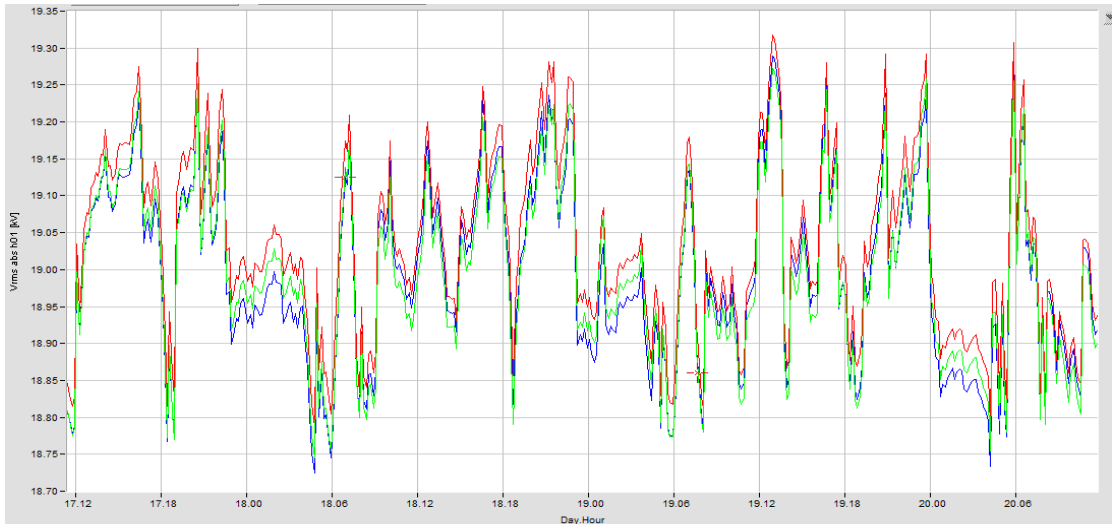

Figure 4.8: Voltage waveform

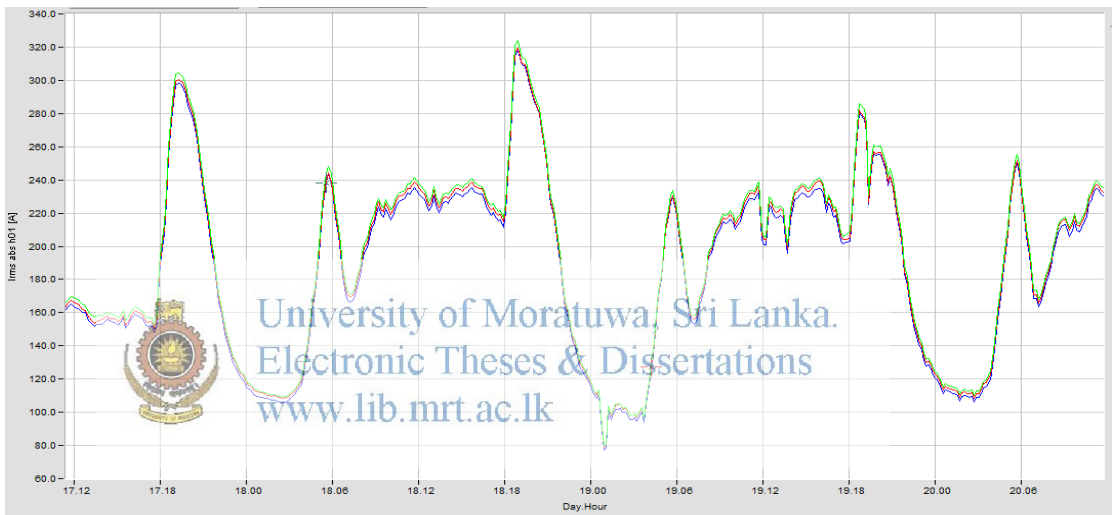

Figure 4.9: Current Waveform

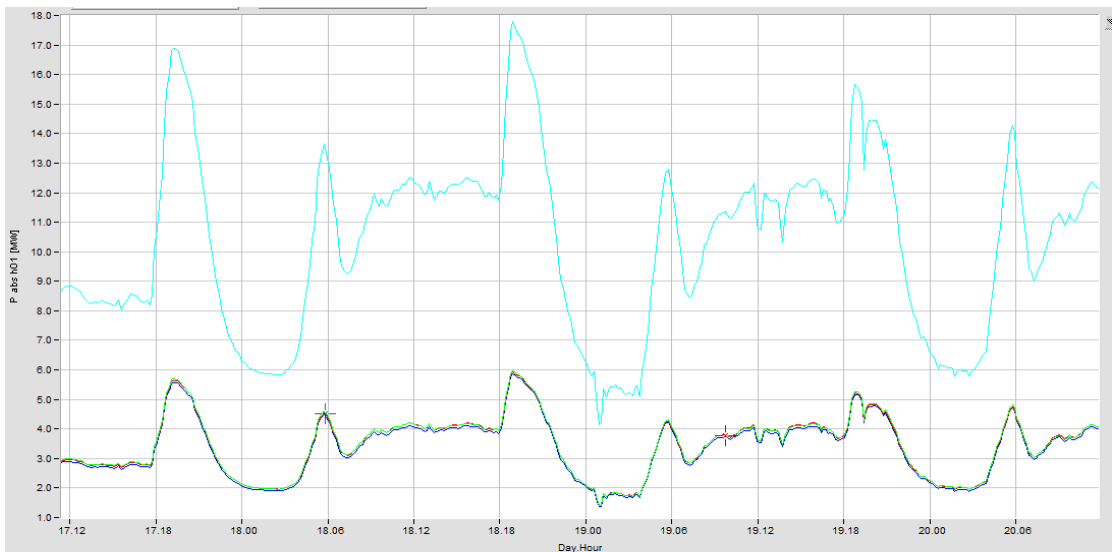

Figure 4.10: Active power measurement

#### 4.5 Power factor variation

The figure 4.11 shows the pattern of the power factor in the substation load. It shows a regular daily pattern with one peak at around 6hr in the morning during morning peak and the other peak around 18 hr during the night peak time.

High peak of the power factor means an improvement of the power factor during these two time periods. At these time periods from the figure 4.9 it can be clearly observed that the load is increased. This is mainly because the lighting loads at the morning and night peak of the system. Since the load increases during these two periods the voltage drop can be seen. This is clearly seen by the voltage wave from shown in the figure 4.8.

Further from the graph it is clearly seen that the power factor varies from 0.90 to 0.98. The best possible way to a power system to operate is to have a unity power factor. By having capacitor banks the power factor can be improved. Therefore the available resources at Thulhiriya substation is not utilized due to technical problem even the requirement is available.

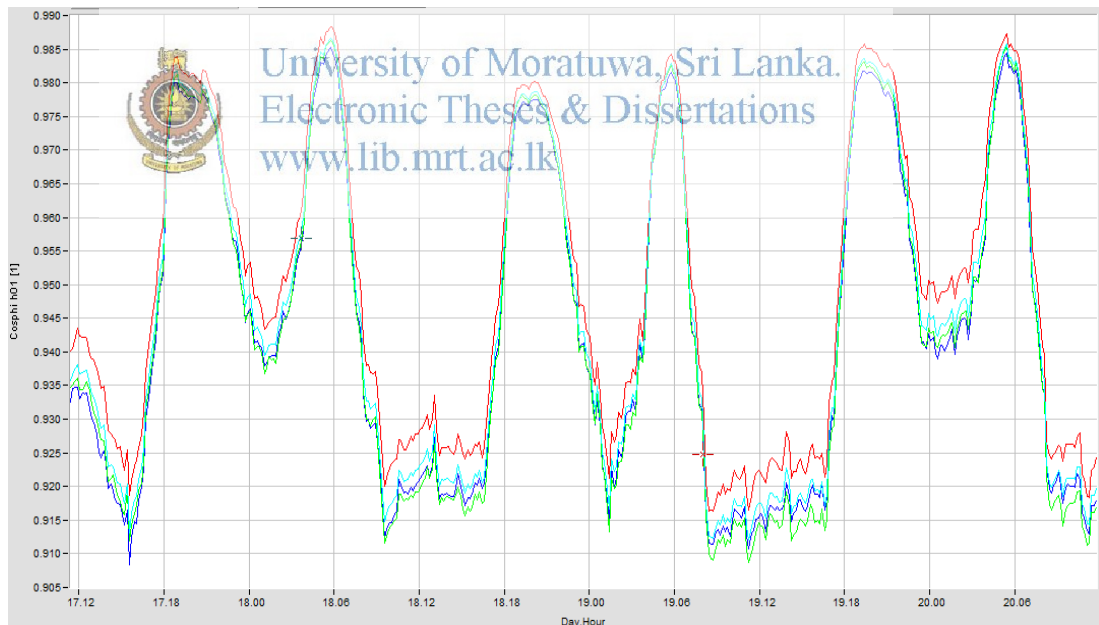

Figure 4.11: Power Factor Variation

#### 4.6 Mvar requirement

The figure 4.12 shows the reactive power requirement of the bus section one. This is also showing a regular daily pattern and the reactive power requirement become high during the day time. This is because the substation is located in a highly

industrialized area. Even the reactive power requirement is more 5 Mvar during day time. So this shows the requirement of capacitor banks. Even this bus section is having a 5 Mvar capacitor bank, since it is switched off due to a technical reason the requirement of the reactive power is not catered. The table 4.2 shows the un served reactive power which are more than 5 Mvar during the measured three days when the peak occurs. If the capacitor bank which is available for this bus section switched on during these periods the requirement of Mvar could be reduced.

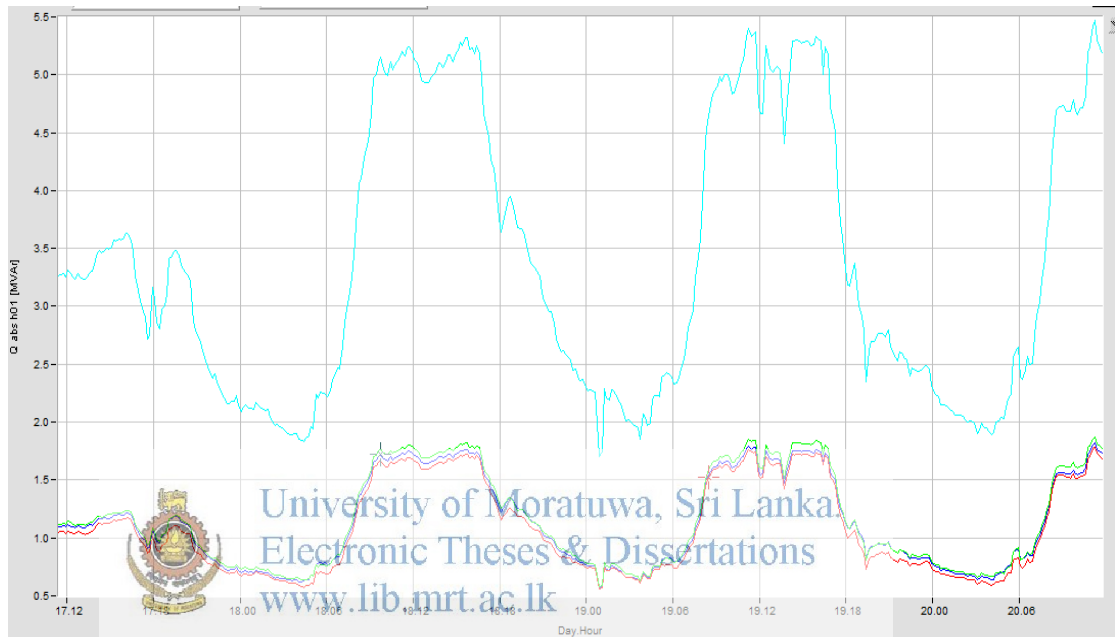

Figure 4.12: Reactive Power Requirement

Table 4.2: Unserved peak reactive power more than 5 Mvar in bus section 01

Day	Time	Total Mvar
2013-10-18	9.35	5.15
2013-10-18	11.55	5.20
2013-10-18	15.45	5.31
2013-10-19	9.45	5.01
2013-10-19	11.15	5.40
2013-10-19	12.25	5.25
2013-10-19	16.05	5.31
2013-10-20	11.15	5.47



#### 4.7 Harmonics in the system

Harmonics available in the bus section one of the substation is also recorded. Harmonics in the current waveform and the harmonics in the voltage wave forms are shown in the figure 4.13 and figure 4.14 respectively. From both the figures it is clearly seen that in both the current and the voltage wave forms fifth and seventh harmonics are more dominant. The obtained harmonics are fed to the PSCAD model during the simulation as a percentage of fundamental frequency.

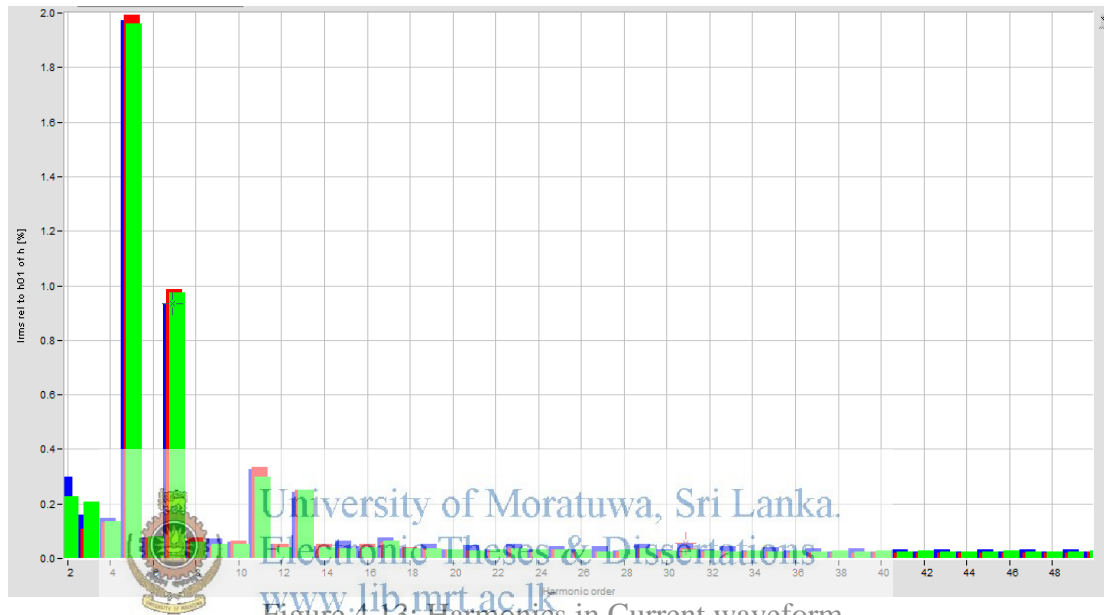

Figure 4.13: Harmonics in Current waveform

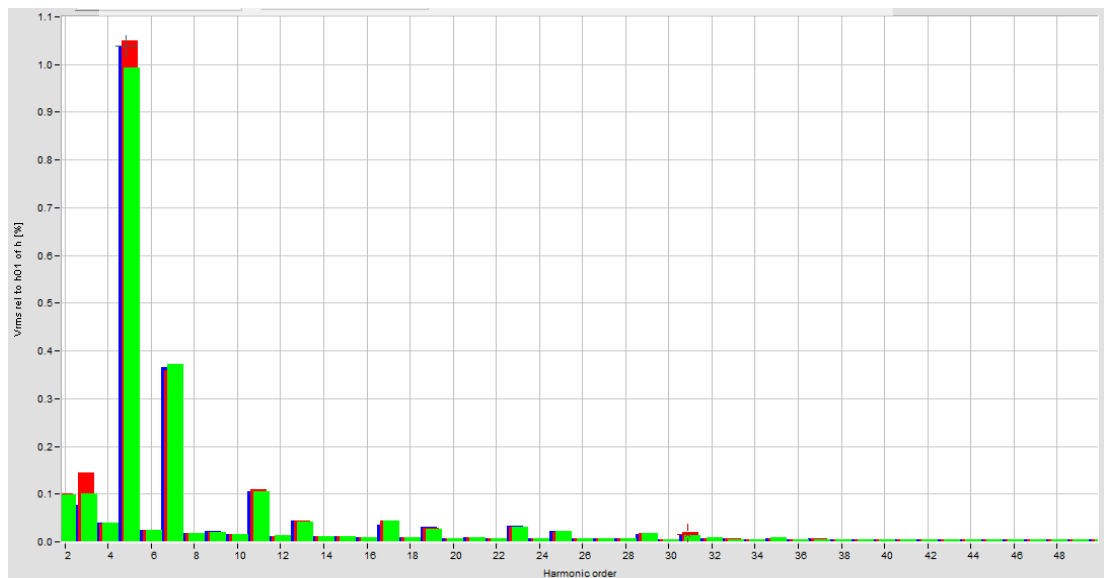

Figure 4.14: Harmonics in Voltage waveform

#### 4.8 Capacitor switching pattern in an average day

Figure 4.15 shows a capacitor switching pattern of the Grid substation by only considering the reactive power requirement. During the day up to 6hr no capacitor bank is needed. But during the day time at least one bank is needed to cater the reactive power requirement of the system.

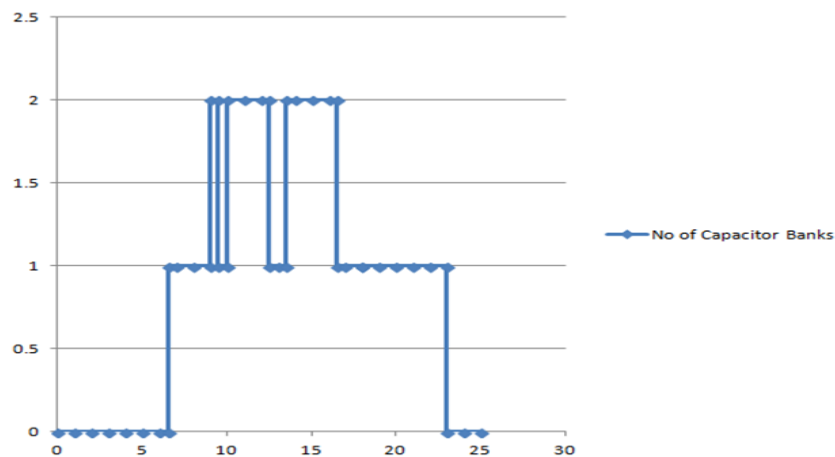

Figure 4.15: Switching pattern for Capacitor Banks at Thulhiriya GSS

#### 4.9 CBT 400 Measurements

The circuit breaker available in Thulhiriya substation for the purpose of switching the capacitor bank is Joslyn circuit breaker which is having a vacuum circuit breaker. It is rated to operate in between 15 kV to 69 kV with continuous current capabilities from 300 A.

However when switching the capacitor banks the position of closing of the circuit breaker in a power cycle is very vital to determine. In such case the circuit breaker operating time, circuit breaker delay time and the circuit breaker arcing time is crucial to determine. So in order to determine the above the CBT 400 equipment is used for the Joslyn breakers of both the banks. The closing time, opening time and the close open time is recorded for both the circuit breakers. The obtained results are shown in the figure 4.16, 4.17, 4.18, 4.19, 4.20 and 4.21. From the graphs obtained it is clearly stated that the closing time of the breaker is in the range of 40 to 45 ms. The opening time of the circuit breaker is in the range of 35 to 40 ms.

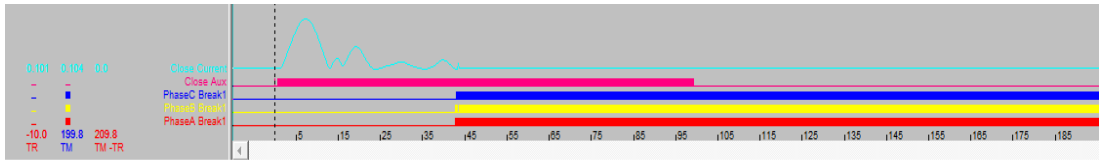

Figure 4.16: Capacitor Breaker of bank one closing

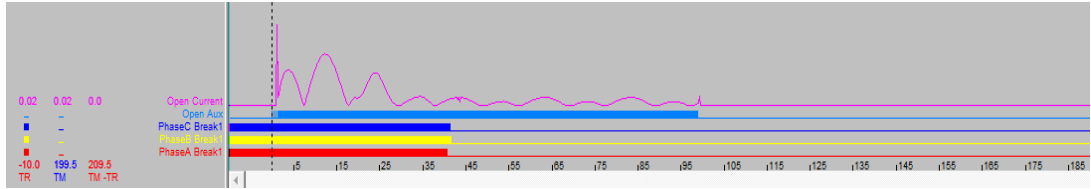

Figure 4.17: Capacitor Breaker of bank one opening

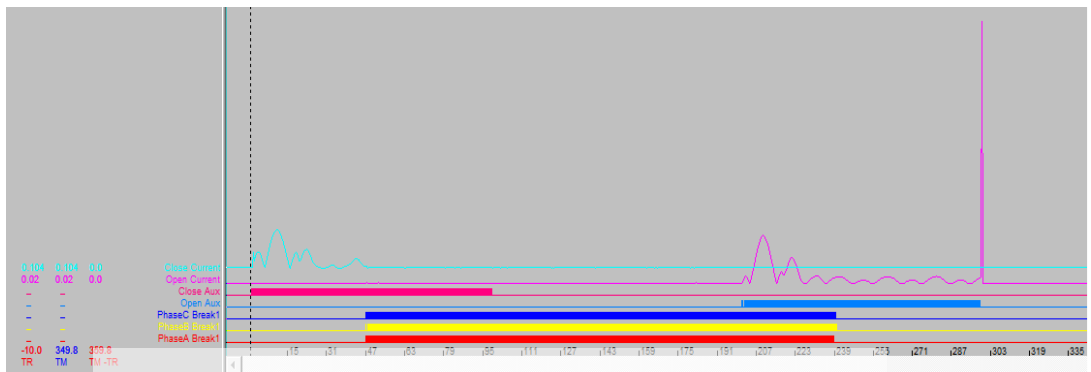

Figure 4.18: Capacitor Breaker of bank one close opening

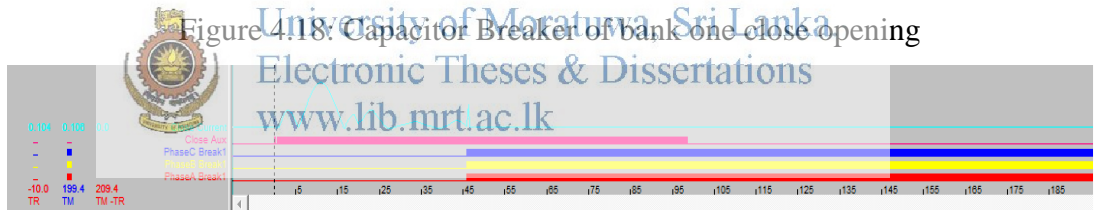

Figure 4.19: Capacitor Breaker of bank two closing

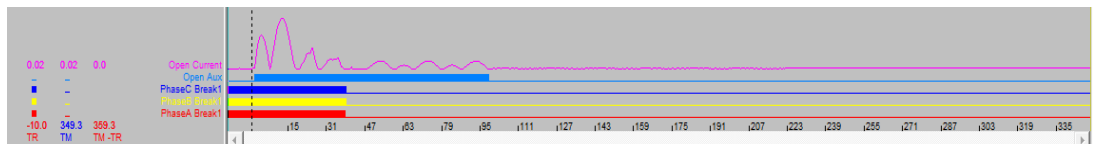

Figure 4.20: Capacitor Breaker of bank two opening

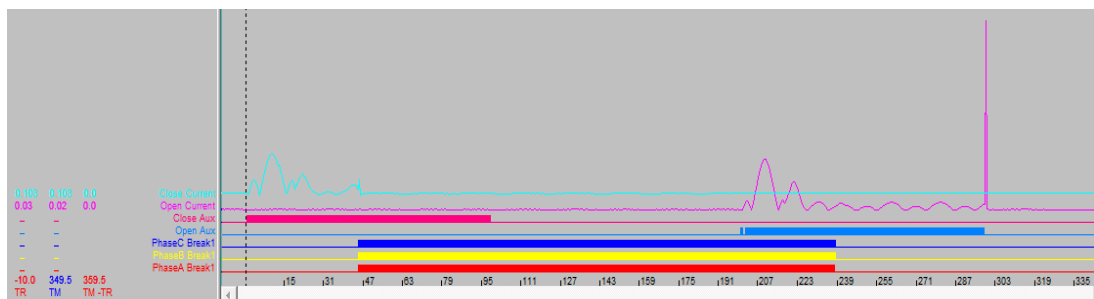

Figure 4.21: Capacitor Breaker of bank two close open

## 5 Methodology

### 5.1 EMTP/ PSCAD modeling and simulation tool

EMTP software's are used by the power utilities to model, analyze and to find solutions for power system transient problems such as lightning effects, GIS switching effects, transient condition analysis, capacitor switching transient analysis, harmonic analysis, power quality issues, power electronics etc. PSCAD is one of the well known EMTP software developed by Manitoba HVDC research centre in Canada, where the concept was brought in 1988 and began its long evolutions a tool to generate data files for EMTDC simulation program. PSCAD was first introduced as a commercial product as Version 2 targeted for UNIX platforms in 1994 and now available for windows platforms with user friendly interface and highly sophisticated tools and well developed simulation engine being fully mature for many years.

PSCAD is a Graphical User Interphase (GUI) software and facilitates the users to create models or circuits, simulate them and to analyze the results in a completely integrated graphical environment. Input output models such as meters, controllers, plotters and graphs are available which can be control during the simulation or run the simulation. Therefore online controlling and monitoring can be done from PSCAD.



University of Moratuwa, Sri Lanka.  
Electronic Theses & Dissertations  
[www.lib.mrt.ac.lk](http://www.lib.mrt.ac.lk)

PSCAD comes with a library of programmed models ranging from small elements to more complex models. Even though the models are available in the library the user can define his own models. Therefore the software is capable of developing models which are not available in the library.

The figure 5.1 shows the graphical user interphase window of the PSCAD software. The GUI can be divided in to four basic working areas namely workspace window, output window, design editor and the rest of the area consists of tool bars, menus and palettes. The workspace window is the central project database for PSCAD which gives an overview of currently loaded projects, master library, data files, signals etc. further it provides the facility to organize them within the workspace window by drag and drop feature. The output window section provides an easily accessible interface for viewing feedback and troubleshooting of the simulation. All the errors and warning messages either given by a component, PSCAD or EMTDC can be

viewed from the output window section and also provides the facility to locate the errors by double clicking on the error message. The design editor is the place where most of the project design work is performed. The design editor is used mostly for the graphical construction of circuits and also includes an embedded component definition editor.

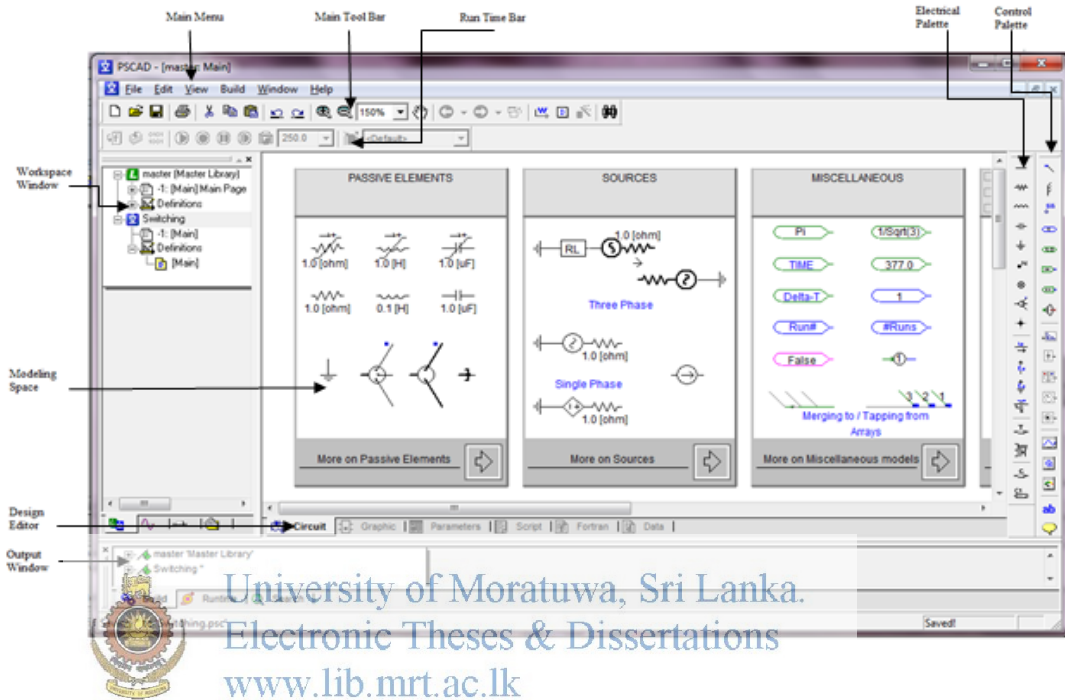

Figure 5.1: Typical working window of PSCAD software

The PSCAD is used as the EMTP software in this Phase study for modeling the Thulhiriya substation and analyses of capacitor switching transient. Most of the equipment is modeled by using the standard library models available in the PSCAD itself. Two of the other software which can be used is PSS/E and MATLAB Simulink. But PSS/E is a software for steady state analysis which can be used for load flow analysis and hence not suitable for transient analysis. Since PSCAD library has already developed models for almost all the power equipment it is preferred over MATLAB Simulink to avoid more coding in developing equipment.

## 5.2 Grid model

Main substation equipment such as power transformers, grounding transformers, circuit breakers, loading, capacitor banks etc are used in the model and they are available in the master library in PSCAD.

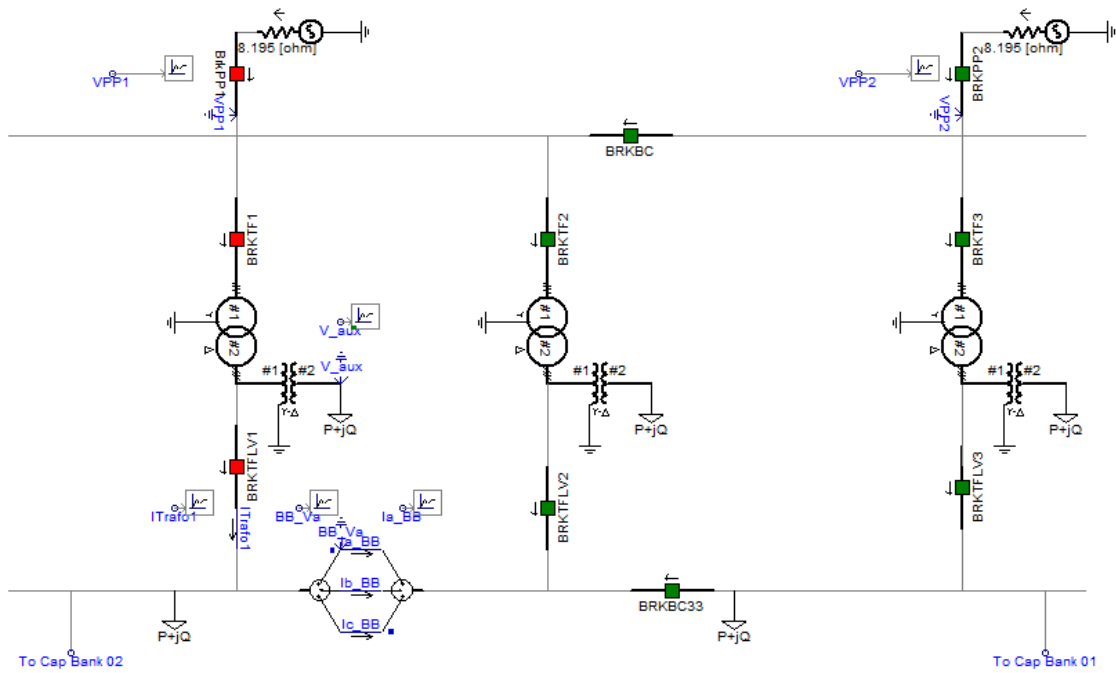

Figure 5.2: Grid Model

### 132 kV incomers

132 kV incomers are modeled as three phase voltage sources. The conductor used for Thulhiriya 132 kV incomers is Lynx. The DC resistance of the Lynx conductor is  $0.1576 \Omega/\text{km}$  (Appendix 03). The total length of the transmission line is 52 km. therefore the resistance of the transmission line is calculated as  $8.195 \Omega$ .

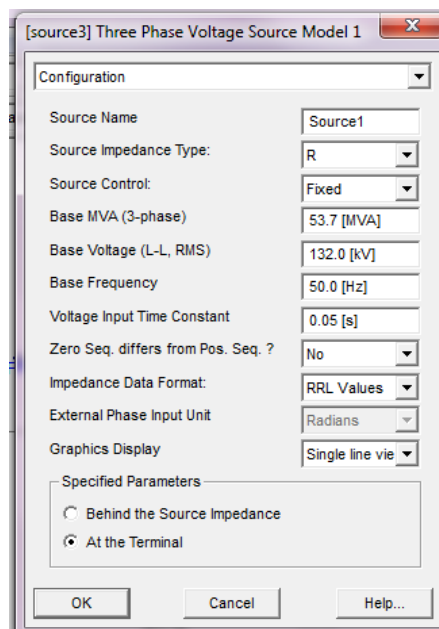

Figure 5.3: Configuration of 132 kV incomers

### 132/ 33 kV Transformers

The transformers are modeled as two winding transformers where the real transformer is approximated to the simplest form. The simple two winding transformer model available at the master library is used for the model. The parameters used for the transformers are shown in the figure 5.4.

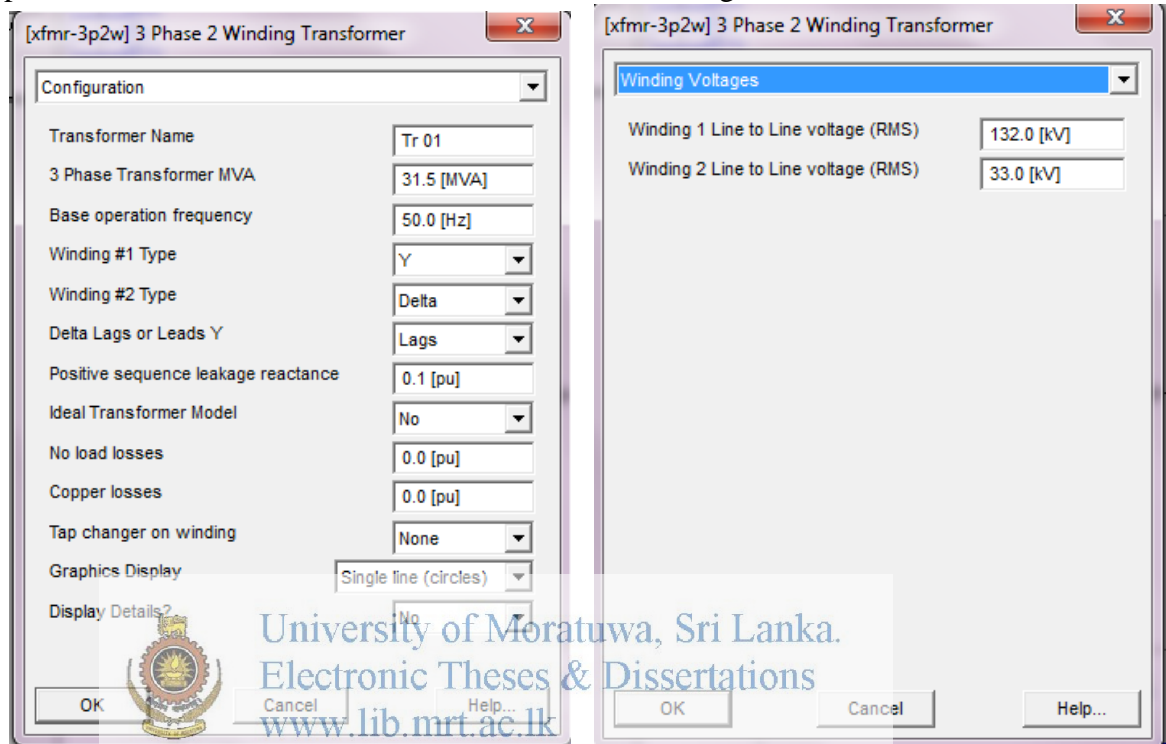

Figure 5.4: Configuration of 132/ 33 kV transformer

### 5.3 Capacitor bank model

The total available capacity of the capacitor banks at Thulhiriya substation is two numbers of 5 Mvar capacitor banks adding 10 Mvar to the 33 kV bus. Each capacitor bank is having 12 numbers of  $14\mu\text{F}$  capacitor units. All the capacitor units are connected as ungrounded double star. Each limb is having two capacitor units. The capacitor bank one is connected to the 33 kV bus section one via a 12mH inrush limiting reactor where as the capacitor bank two is connected to the 33 kV bus section two via a 36 mH detuning reactor. Figure 5.5 and 5.6 are showing capacitor bank 01 and 02 respectively.

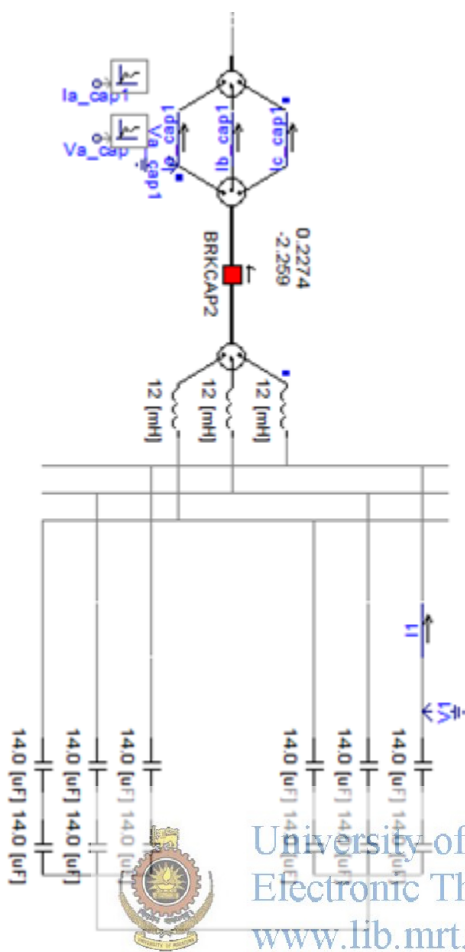

Figure 5.5: Capacitor Bank 01

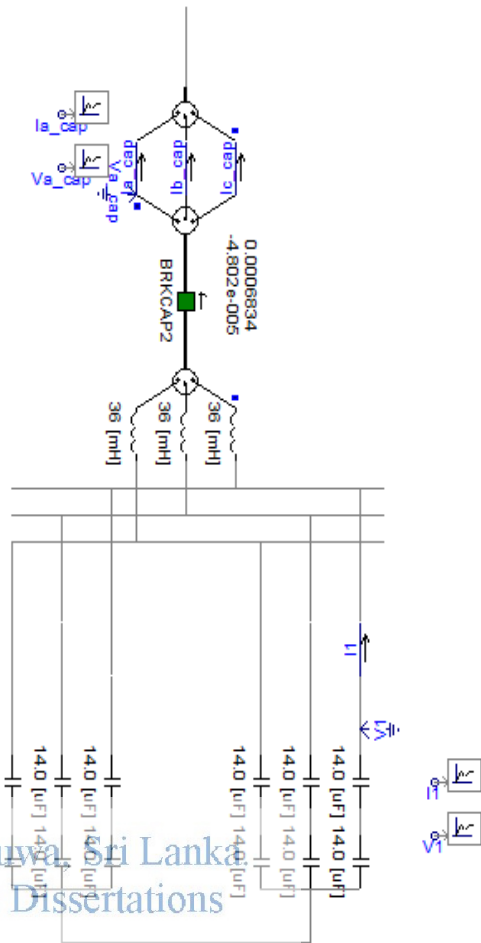

Figure 5.6: Capacitor Bank 02

The operation sequence of a capacitor bank is simulated from the time delay blocks shown in figure 5.6. The capacitor bank switching can be done at any point of a power cycle by delaying the time in the third block.

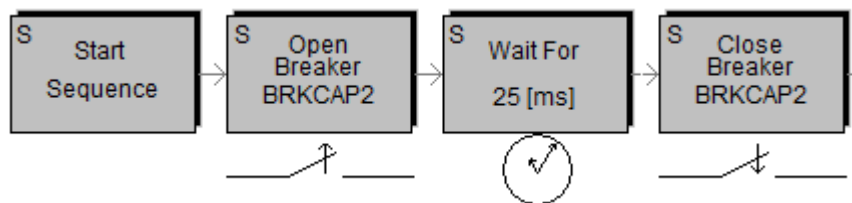

Figure 5.7: Time Delay Blocks for switching

#### 5.4 Control panel

The circuit breaker control panel is shown in the figure 5.8. Each and every control panel is linked with every circuit breaker for operations.



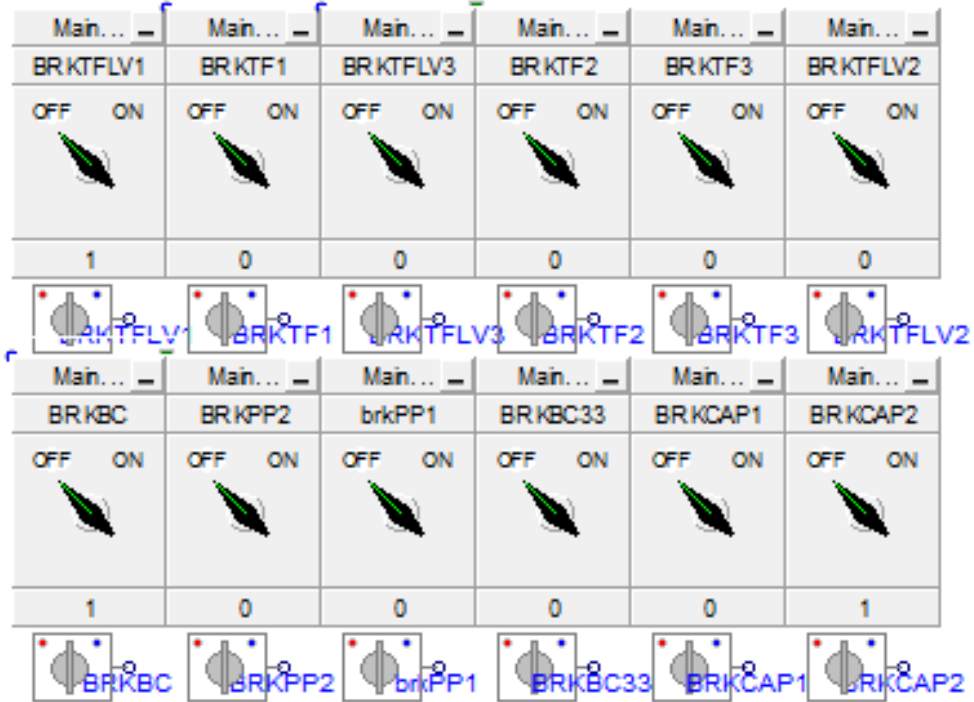

Figure 5.8: Control Panel of Circuit Breakers

### 5.5 Harmonic model.

Harmonics are added to the 33 kV bus as current sources during the simulation. Magnitudes of the harmonics are decided and added as per the actual measurements obtained from the power quality analyzer. This is done to achieve actual scenario during the simulation. The figure 5.9 shows the method of adding harmonics to the system.

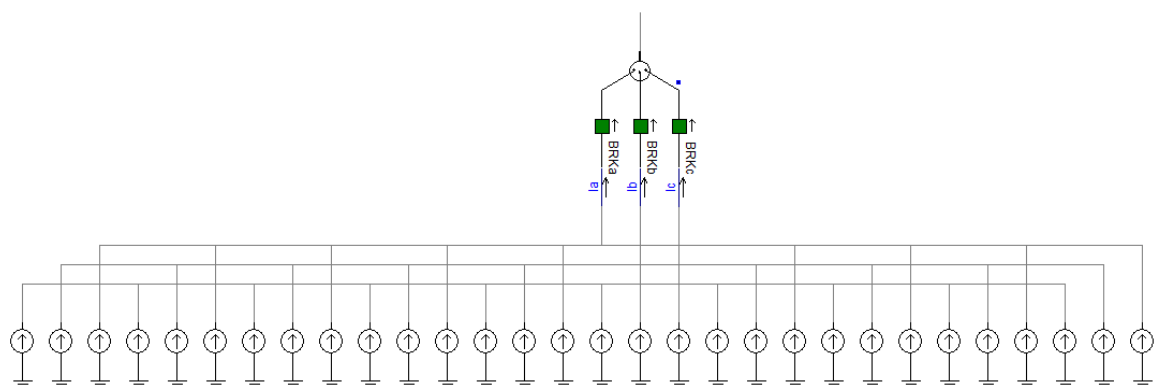

Figure 5.9: Addition of Harmonics

## 5.6 Fast Fourier transform

The figure 5.1 shows an online Fast Fourier Transform (FFT) module, which can determine the harmonic magnitude of whatever the input signal as a function of time. The output of the FFT which is magnitudes of the harmonics are then fed to a harmonic distortion calculator to find out the total harmonic distortion (THD) of the 33 kV bus. Then the output of the harmonic distortion calculator is sent to a polypmeter to show the individual harmonic magnitudes and the THD. By using a data merge the individual harmonic levels and the THD can be shown in control panels.

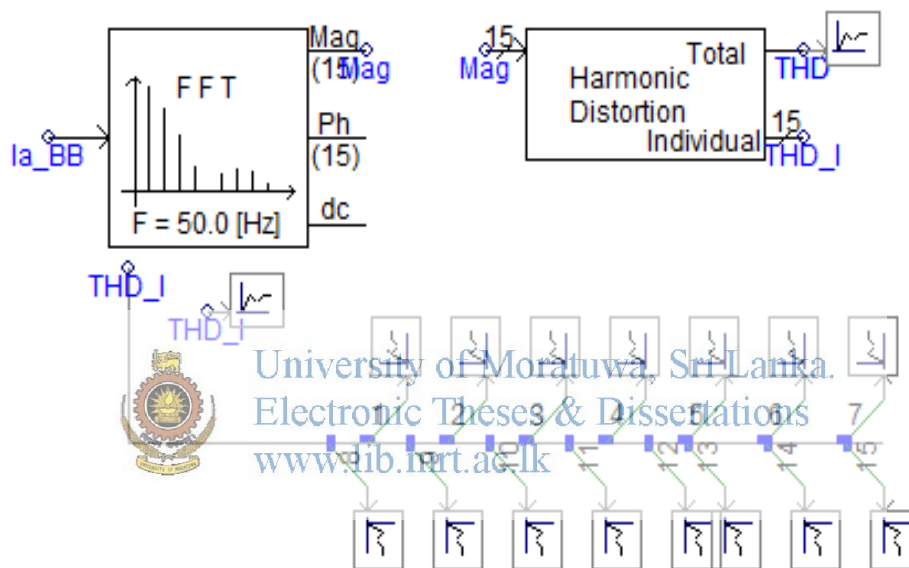

Figure 5.10: Online Fast Fourier Transformer

## 5.7 Model validation

First of all the simulation is run against a known set of data which are obtained from the PQ analyzer output (figure 4.8, 4.10 and 4.12). For easiness the measurement are compared with the actual measurements for two hour intervals in an average day (18<sup>th</sup> October 2013). Since the PQ analyzer data is obtained for bus section one the measurements are also obtained for bus section one. The exact loading is done for the 33 kV bus section one at the particular time and the 33 kV bus section one voltage is measured from the simulation. The simulation is done without connecting the capacitor banks as in the actual scenario. The measured data and the simulated

data are tabulated in table 5.1. The results obtained from the simulation shows that the model gives approximately same results as in actual PQ analyzer measurement. Obtained PQ analyzer 33 kV bus section one voltage is showing the line to earth rms voltage and hence the simulated voltage is also measured as line to earth voltage. The obtained waveforms from the simulation are attached as Appendix 8.

Table 5.1: Comparison between measured and simulated data

Time	Measured data			Simulated data	
	MW (33 kV)	Mvar (33kV)	kV (33kV)L-E rms	V (33kV) L-E peak	V (33kV) L-E rms
02.00	5.9	2.1	19.05	26.17	18.51
04.00	7.3	1.4	19.00	26.24	18.56
06.00	13.0	2.3	18.90	26.12	18.47
08.00	9.3	2.7	19.20	26.11	18.46
10.00	11.6	5.0	19.03	25.91	18.32
12.00	12.4	5.2	19.01	25.89	18.31
14.00	12.0	5.1	19.03	25.90	18.32
16.00	12.5	5.3	19.05	25.88	18.30
18.00	12.0	3.7	19.10	26.01	18.39
20.00	16.8	3.5	19.08	25.99	18.38
22.00	9.2	2.6	19.20	26.12	18.47
24.00	6.2	2.3	18.95	26.16	18.50

### 5.8 Measured parameter from the simulation

For the analysis following parameters were measured,

- Measured Voltages
  - 33kV Bus Bar voltage
  - Capacitor feeder voltage
- Measured Currents
  - 33 kV feeder current
  - Capacitor feeder current

## 5.9 Step by step simulation

The study has been done step by step in the following order.

- Switching of Capacitor bank 1
- Switching of Capacitor bank 2
- Switching of Bank 1 & 2 for different load configuration
- Back to Back switching
  - (Sequence Capacitor Bank 1, Capacitor bank 2)
- Back to Back switching
  - (Sequence Capacitor Bank 2, Capacitor bank 1)
- Fast switching
  - (Sequence Capacitor Bank 1, Capacitor bank 2)
- Fast switching
  - (Sequence Capacitor Bank 2, Capacitor bank 1)
- Harmonic Analysis
  - Energizing Capacitor Bank 1
  - Energizing capacitor bank 2
  - Energizing both the banks
    - (Sequence Capacitor Bank 1, Capacitor bank 2)
    - (Sequence Capacitor Bank 2, Capacitor bank 1)



## 6 Results and analysis

### 6.1 Separate witching of capacitor banks

As the first step to the simulation the separate capacitor switching is done with the modeled substation to find out the transient behavior and their magnitudes at the time of energizing the capacitor banks. There by first the energizing of capacitor bank one is analyzed and then energizing of capacitor bank two is analyzed. First the wave forms are recorded for average loading of the substation as in figure 6.1.

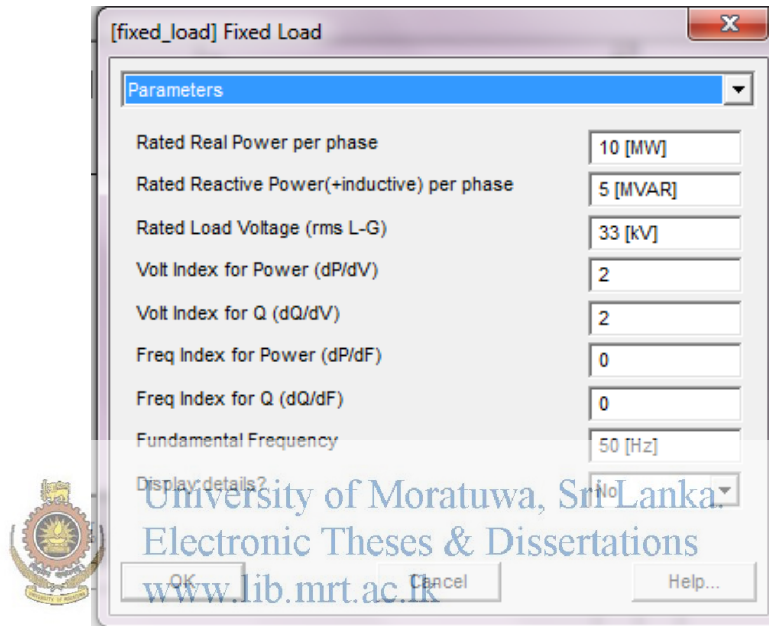

Figure 6.1: Average loading configuration

And then it is done for several loading conditions as obtained from the measurement data of the substation. For the maximum loading the simulation is run for each and every millisecond between a power cycle to have more sensitive measurements.

#### 6.1.1 Capacitor bank No 01

For the switching of capacitor bank one with 12 mH reactor, waveforms are obtained. Figure 6.2 and Figure 6.3 shows how the system behaves after energizing the capacitor bank one at zero crossing and the voltage peak which is the worst case scenario.

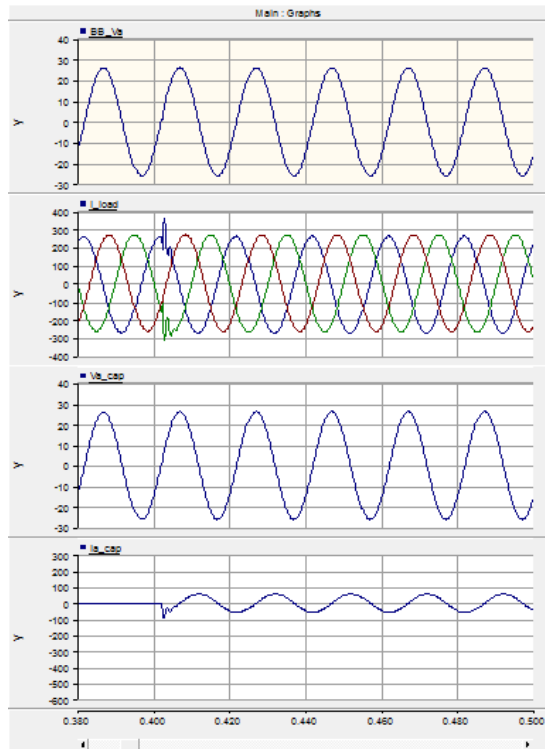

Figure 6.2: Energizing of capacitor bank

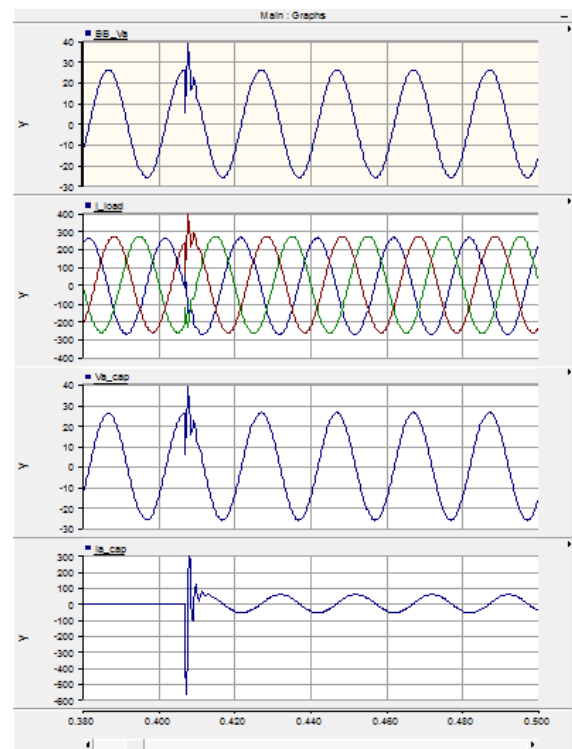

Figure 6.3: Energizing of capacitor bank

one at zero crossing

one at voltage peak

The simulation is run for each and every millisecond of a power cycle to find out a tolerable limit for the switching of the capacitor bank with minimum transients (Appendix 9). Voltage of the 33 kV bus and the current is obtained from the graphs and tabulated as a percentage of the steady state value (table 6.1).

With the results obtained it can be clearly stated that any transient under 130 % of the steady state magnitude is not showing much of an impact to the power quality. Thus by analyzing the voltage waveforms obtained, + or – 2 ms around zero crossing can be given as a tolerable limit and safe region for the operation of the capacitor bank.

Table 6.1: Voltage and current transient percentage for different switching time of bank one

Time (ms)	Voltage (%)	Current (%)
0	100	100
1	102	104
2	109	112
3	137	115
4	148	146
5	151	154
6	136	150
7	108	135
8	103	108
9	101	103
10	100	100

### 6.1.2 Capacitor bank No 02

For the switching of capacitor bank one with 36 mH reactor waveform are obtained. Figure 6.4 and figure 6.5 shows how the system behaves after energizing the capacitor bank one at zero crossing and the voltage peak which is the worst case scenario.

The simulation is run for each and every millisecond of a power cycle to find out a tolerable limit for the switching of the capacitor bank with minimum transients (Appendix 10). Voltage of the 33 kV bus and the current is obtained from the graphs and tabulated as a percentage of the steady state value.

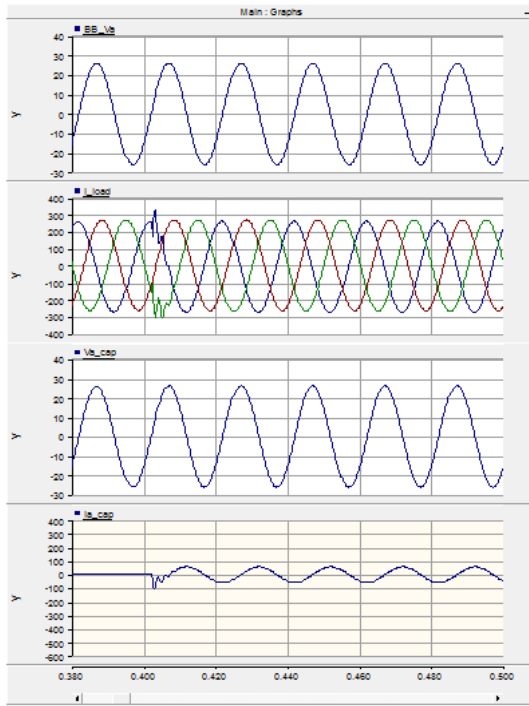

Figure 6.4: Energizing of capacitor bank two at zero crossing

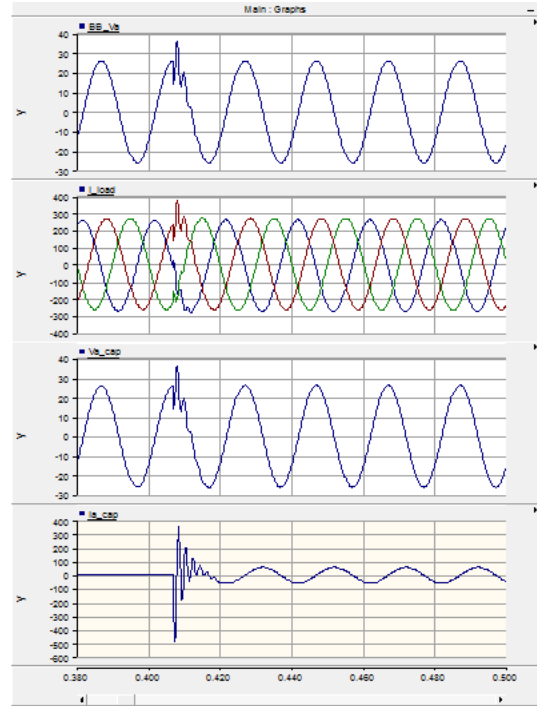

Figure 6.5: Energizing of capacitor bank two at voltage peak

Table 6.2: Voltage and current transient percentage for different switching time of bank two

Time (ms)	Voltage (%)	Current (%)
0	100	100
1	102	103
2	109	111
3	130	119
4	137	131
5	141	149
6	119	144
7	108	121
8	105	106
9	101	102
10	100	100



With the results obtained it can be clearly stated that any transient under 130 % of the steady state magnitude is not showing much of an impact to the power quality. Thus by analyzing the voltage waveforms obtained, + or – 2 ms around zero crossing can be given as a tolerable limit and safe region for the operation of the capacitor bank.

### 6.1.3 Switching with different 33kV loading

To have more sensitive results with capacitor switching the simulation is done for several 33 kV loading values and analyze the transients in each cases. Ten numbers of load values (table 6.3) which are randomly selected from power quality analyzer measurements are fed to the model.

Table 6.3: Randomly selected real loads for sensitivity analysis

Time (hr)	Mw	Mvar
00.30	20.4	7.3
04.00	21.7	7.5
06.00	40.6	9.8
09.00	32.5	15.9
12.00	38.3	19.4
15.00	38.4	19.3
17.00	38.2	18.6
19.30	58.0	15.8
21.30	43.4	12.7
23.00	27.2	9.7

Table 6.4 and table 6.5 show the transient percentage when switching of capacitor bank one and two for the randomly selected loads respectively. For this only the closing at peak of the waveform is considered as this is the worst case scenario and the highest transient occurs at the closing at the peak of the waveform. Almost similar readings are obtained from all the various loading values. Obtained waveforms are attached as Appendix 11 and Appendix 12 for the switching of capacitor bank one and two respectively. The table 6.4 and table 6.5 shows the

percentage of the transient from the steady state value for different loading of the 33 kV bus for the switching of capacitor bank one and two respectively.

Table 6.4: Voltage and current transient percentage for different switching time of bank one for randomly selected loads

<b>Time (hr)</b>	<b>Voltage (%)</b>	<b>Current (%)</b>
00.30	133	130
04.00	136	147
06.00	111	110
09.00	119	109
12.00	112	112
15.00	112	112
17.00	112	112
19.30	108	105
21.30	111	114
23.00	123	119



University of Moratuwa, Sri Lanka.  
Electronic Theses & Dissertations

www.lib.mru.ac.lk

Table 6.5: Voltage and current transient percentage for different switching time of bank two for randomly selected loads

<b>Time (hr)</b>	<b>Voltage (%)</b>	<b>Current (%)</b>
00.30	134	128
04.00	130	137
06.00	119	120
09.00	115	122
12.00	114	116
15.00	114	116
17.00	114	116
19.30	111	111
21.30	113	121
23.00	122	125

## 6.2 Back to back switching

Then the simulation is run for back to back switching of capacitor banks to identify the system behavior when a capacitor bank is energized while the other bank in service.

### 6.2.1 Sequence Capacitor bank 01, 02

First the simulation is run to energize capacitor bank one and then the bank two is energized. This is done for closing at waveform zero crossing (figure 6.6) and at peak value (figure 6.7).  $I_{a\_cap1}$  and  $I_{a\_cap}$  are the currents in the capacitor feeder 1 and 2 respectively.

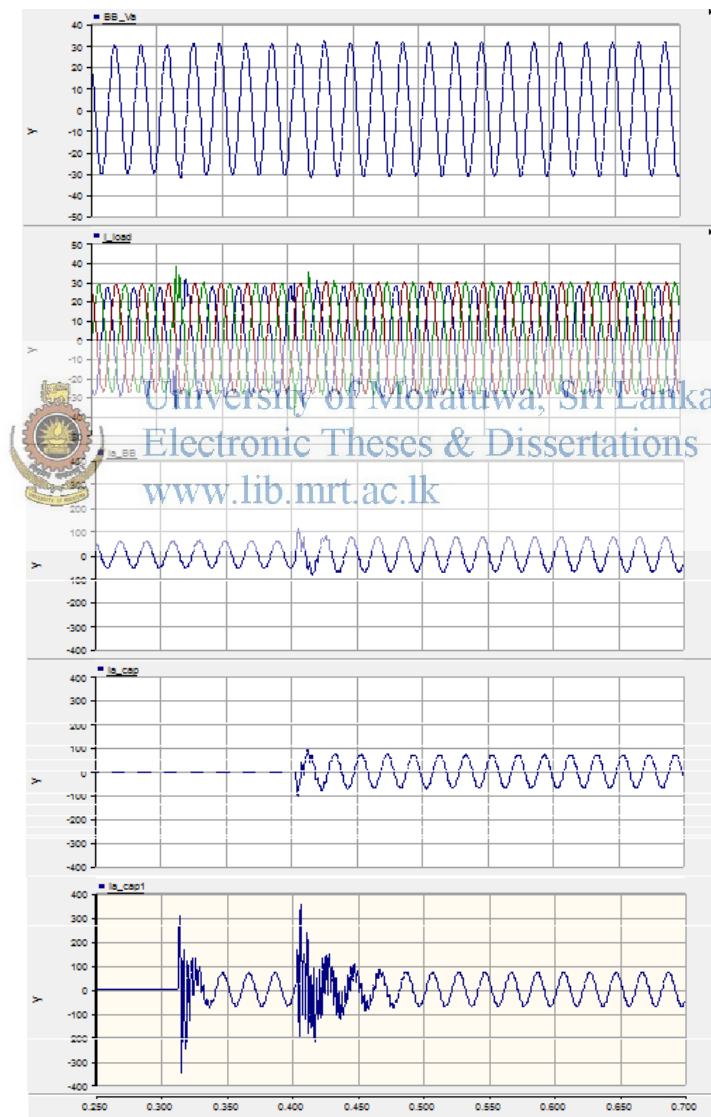

Figure 6.6: Back to back switching sequence of capacitor bank one to two at zero crossing

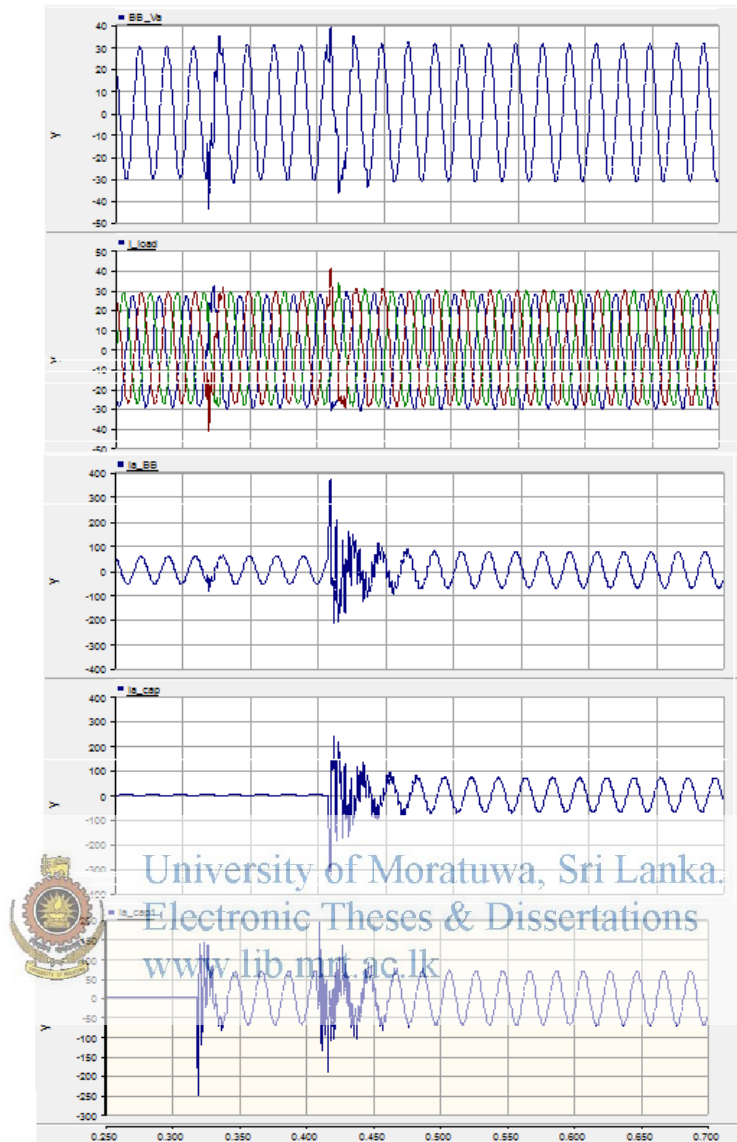

Figure 6.7: Back to back switching sequence of capacitor bank one to two at voltage peak

### 6.2.2 Sequence Capacitor bank 02, 01

Then the simulation is run to energize capacitor bank two and then the bank one is energized. This is also done for closing at waveform zero crossing (Figure 6.8) and at peak value (figure 6.9).  $I_{a\_cap1}$  and  $I_{a\_cap}$  are the currents in the capacitor feeder 1 and 2 respectively.

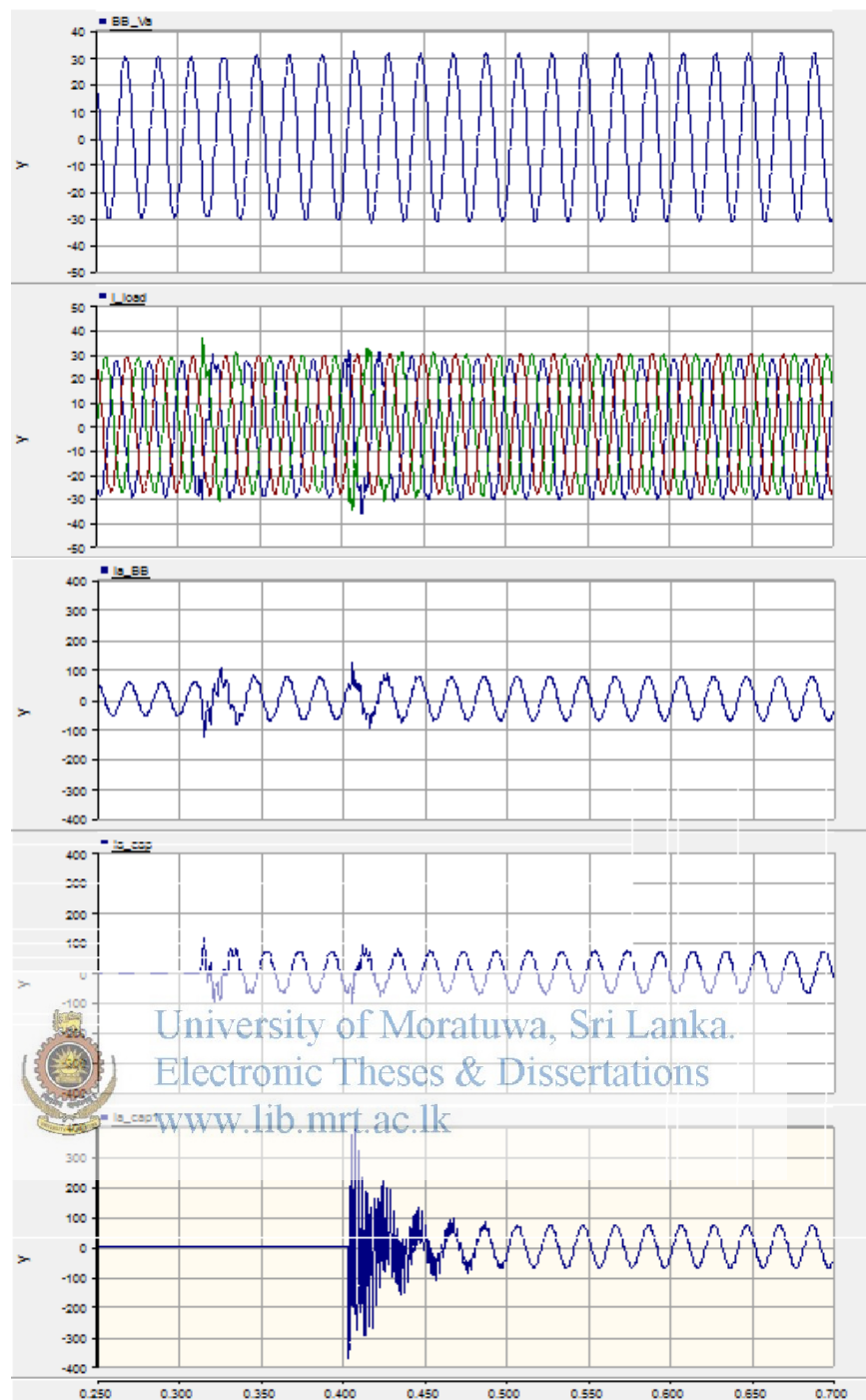

Figure 6.8: Back to back switching sequence of capacitor bank two to one at zero crossing

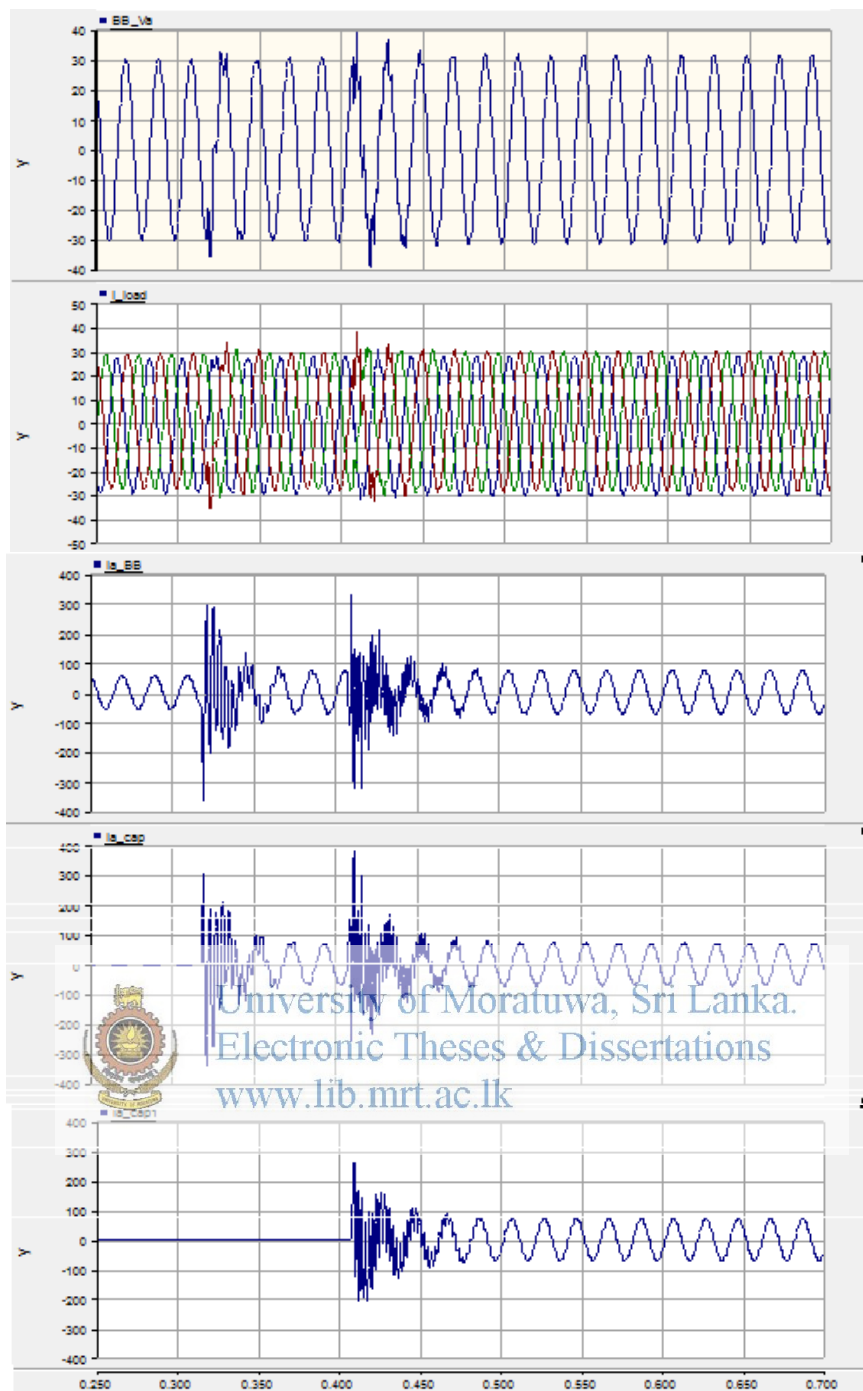

Figure 6.9: Back to back switching sequence of capacitor bank two to one at voltage peak

As per the waveforms obtained, switching of the Capacitor bank 1 produces higher transients than switching of Capacitor bank 2. If the banks are switched in zero crossing then the switching sequence is immaterial by only considering transient (not consider harmonics). In the case of back to back switching, switching of capacitor bank 2 and then capacitor bank one gives less effect to the waveform.

### 6.3 Fast switching

In the previous sub topic the back to back switching of the capacitor banks were considered. The back to back switching can be done in such a way that the banks are switched in very short period of time. During the fast capacitor switching transients can occur on top of the other and create greater transients. This will cause stresses to GSS equipment and result insulation failures and reduction of life time of the equipment. Therefore the switching of the second capacitor bank should be delayed in such a manner to avoid over lapping of the transients. Anyway this type of time delays should be introduced to both the manual and auto operation of the capacitor banks. In auto operation a certain time delay should be added to the settings of the controller of the capacitor banks.

#### 6.3.1 Sequence Capacitor bank 01, 02

First the simulation is run for the sequence of capacitor bank one and then capacitor bank two energizing for an average loading of 33 kV. The delay is increased in 1 ms time intervals and obtained the wave forms (Appendix 13). Figure 6.10, figure 6.11 and figure 6.12 shows the delay time of 3 ms, 10 ms and 17 ms respectively. From the figure 6.10 it can be clearly seen that the transient over lapping produces higher transients than when the transients are not over lapping (Figure 6.12). In this case capacitor bank two should be at least delayed by 10 ms to avoid transient over lapping.

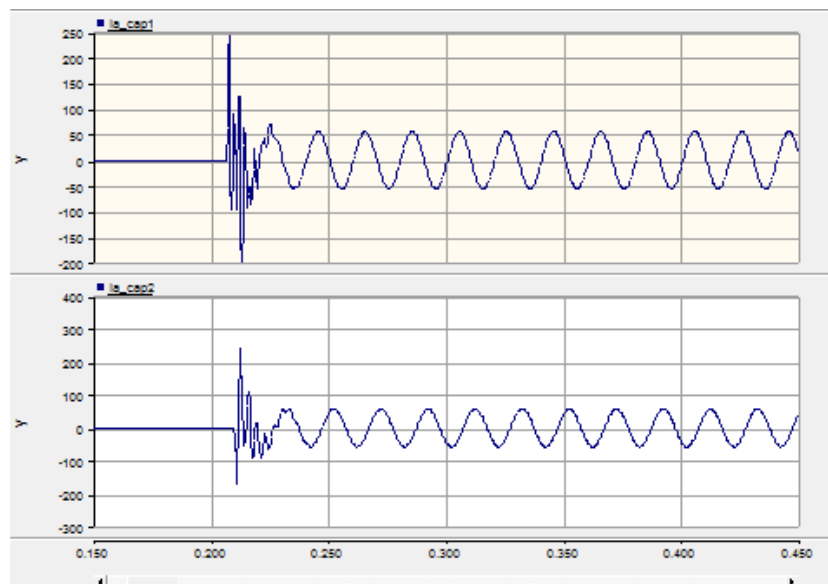

Figure 6.10: Fast switching sequence of bank one to two at 3ms delay

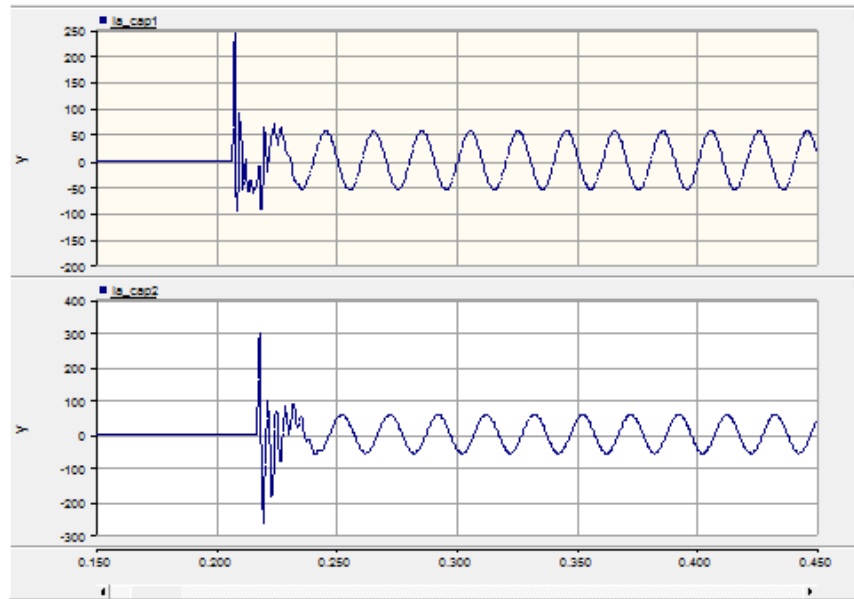

Figure 6.11: Fast switching sequence of bank one to two at 10ms delay

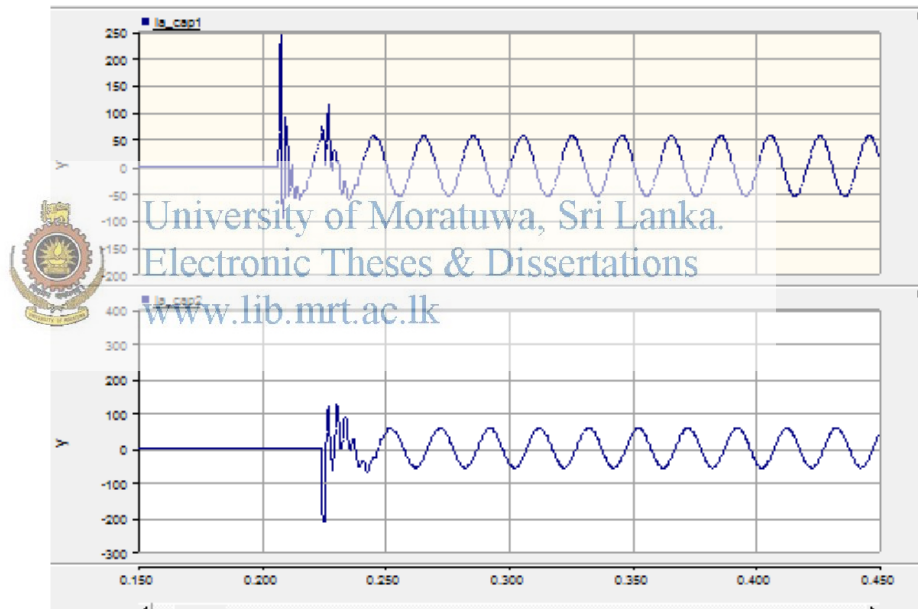

Figure 6.12: Fast switching sequence of bank one to two at 17ms delay

### 6.3.2 Sequence Capacitor bank 02, 01

Then the simulation is run for the sequence of capacitor bank two and then capacitor bank one energizing for an average loading of 33 kV. The delay is increased in 1 ms time intervals and obtained the wave forms (Appendix 14). Figure 6.13, figure 6.14 and figure 6.15 shows the delay time of 12 ms, 28 ms and 38 ms respectively. From the figure 6.13 it can be clearly seen that the transient over lapping produces higher



transients than when the transients are not over lapping (Figure 6.15). In this case capacitor bank two should be at least delayed by 28 ms to avoid transient over lapping.

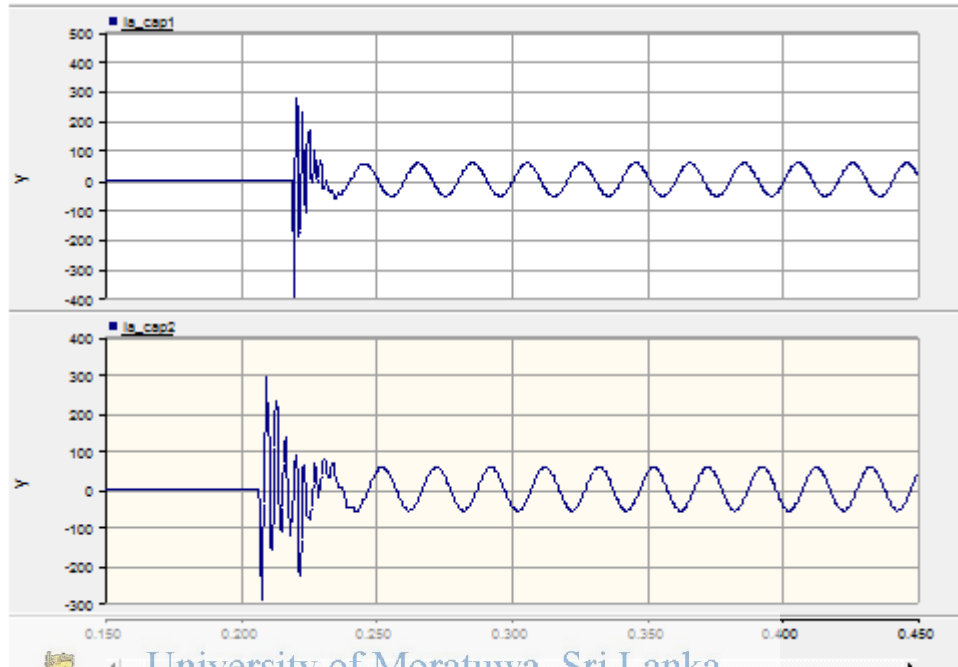

Figure 6.13: Fast switching sequence of bank two to one at 12ms delay

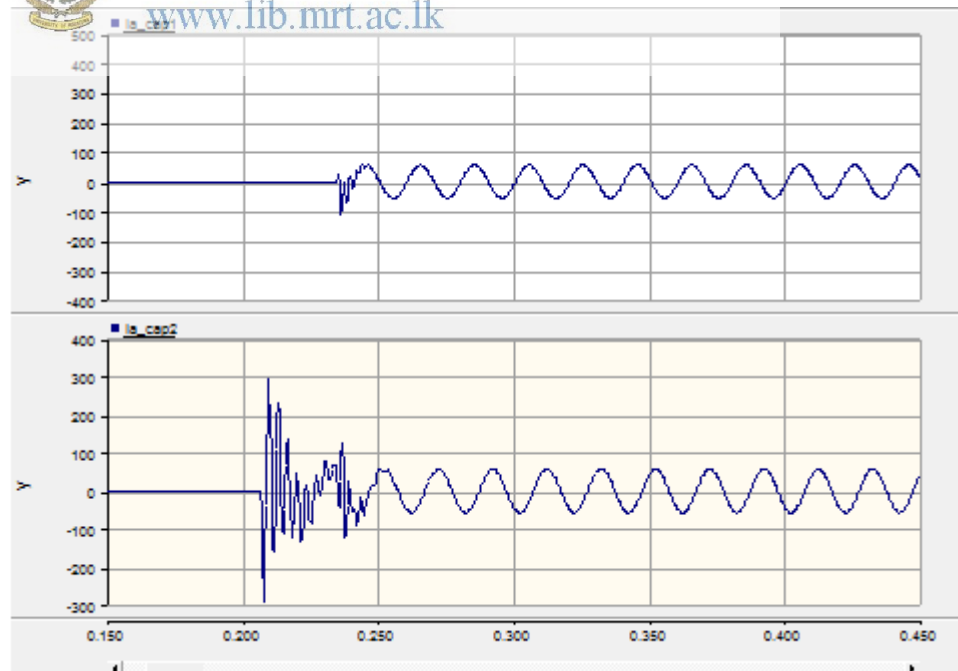

Figure 6.14: Fast switching sequence of bank two to one at 38ms delay

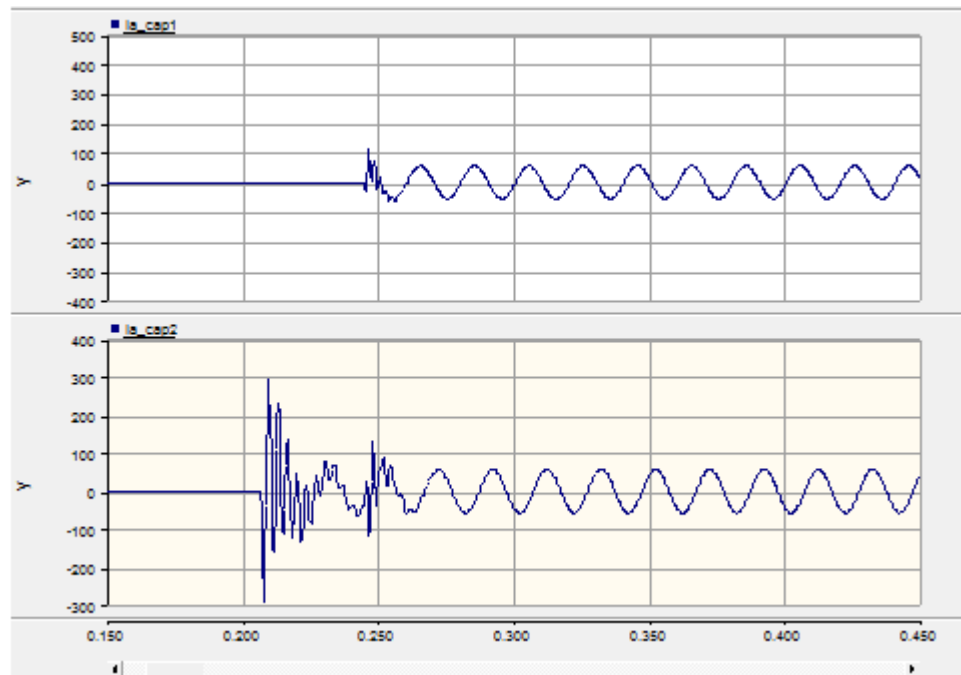

Figure 6.15: Fast switching sequence of bank two to one at 12ms delay

### 6.3.3 Fast Switching with different 33kV loading

Fast switching of capacitor banks are also simulated for randomly selected loads of a particular day as obtained from the power quality measurements (table 6.3) to have sensitivity analysis. The obtained waveforms from the simulation are attached as Appendix 15. The summary of the results obtained is shown in the table 6.6.

By considering all the possible loading, if the switching sequence is capacitor bank one to two the minimum of 14 ms time delay should be introduced and if the switching sequence is capacitor bank two to one the minimum of 30 ms time delay should be introduced for the fast back to back switching of capacitor the banks.

Table 6.6: Minimum fast switching time delays to avoid transient

Hour	Switching Sequence	
	Capacitor Bank 1,2 (ms)	Capacitor Bank 2,1 (ms)
00.30	13	30
04.00	11	29
06.00	13	30
09.00	10	28
12.00	11	29
15.00	11	29
17.00	12	28
19.30	08	27
21.30	11	28
23.00	14	30

#### 6.4 Harmonics present in the system

During the power quality analyzer measurement the harmonics present in the 33 kV system is also observed and recorded. Therefore harmonics are added to the system as in the table 6.7, which are the exact measurements of the actual scenario obtained from the PQ analyzer. Magnitudes of the harmonics are shown as a percentage of the fundamental frequency.

The power system after adding the harmonics to the system is shown in the figure 6.16 by a polychrome and the individual panels. Individual harmonic magnitudes can be seen from both the figures. The total harmonic distortion of the system is 2.27 without adding the capacitor banks.

Table 6.7: Measured harmonics in the system

Harmonic order	% from the fundamental Frequency
1	100
2	25
3	20
4	15
5	200
6	10
7	100
8	10
9	09
10	08
11	30
12	07
13	25
14	07

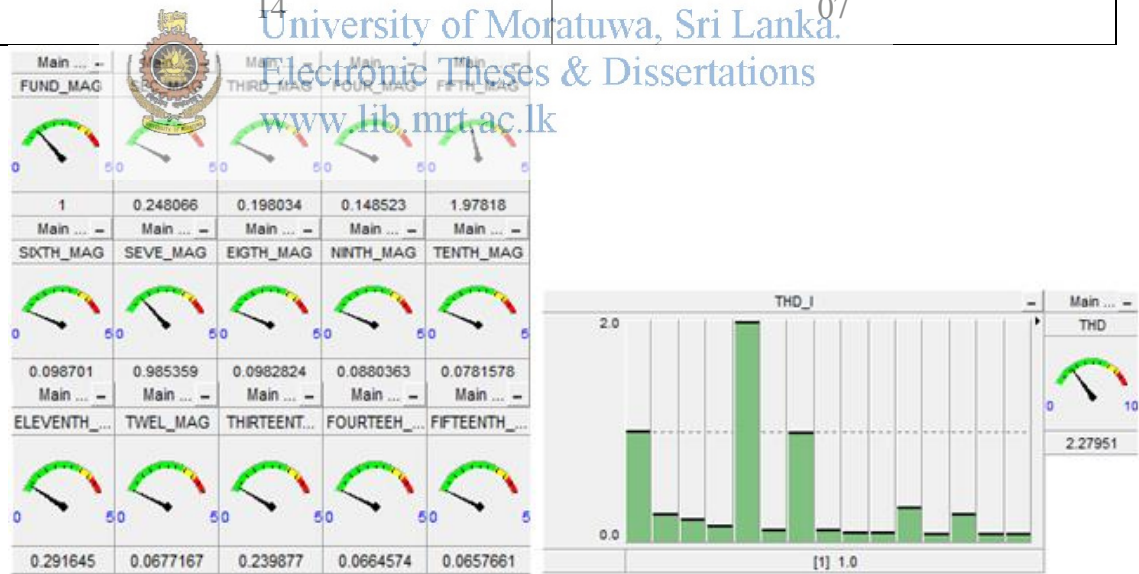

Figure 6.16: Harmonic present in the system without capacitor banks

## 6.5 Harmonics and Total Harmonic Distortion

### 6.5.1 After energizing capacitor bank 01

Harmonics and the total harmonic distortion are obtained from the simulation after energizing of the capacitor bank one. Figure 6.17 shows individual harmonic magnitudes present in the system with the capacitor bank energizing.

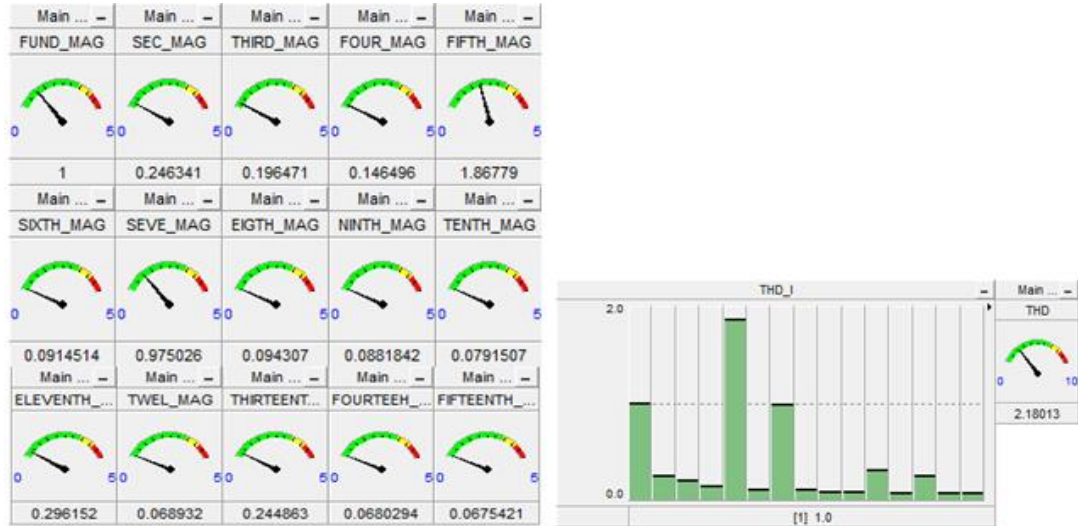

Figure 6.17: Harmonics in the system after switching capacitor bank one

The individual harmonic magnitudes are not having any noticeable difference and as in the system where no capacitor banks are energized, here also the 5<sup>th</sup> and the 7<sup>th</sup> harmonic magnitudes are more dominant in the system. The total harmonic distortion is also 2.18.

### 6.5.2 After energizing capacitor bank 02

Harmonics and the total harmonic distortion are then obtained from the simulation after energizing of the capacitor bank two. Figure 6.18 shows individual harmonic magnitudes present in the system with the capacitor bank two energizing.

The 5<sup>th</sup> harmonic magnitude is almost half the previous values and the 7<sup>th</sup> harmonic magnitude is almost one fourth of the previous values. The other harmonic magnitudes are not having any noticeable difference. Only the 5<sup>th</sup> harmonic is the dominant harmonic in the system when the capacitor bank two is energized. The total harmonic distortion is also 1.05 which is almost half the previous values obtained.

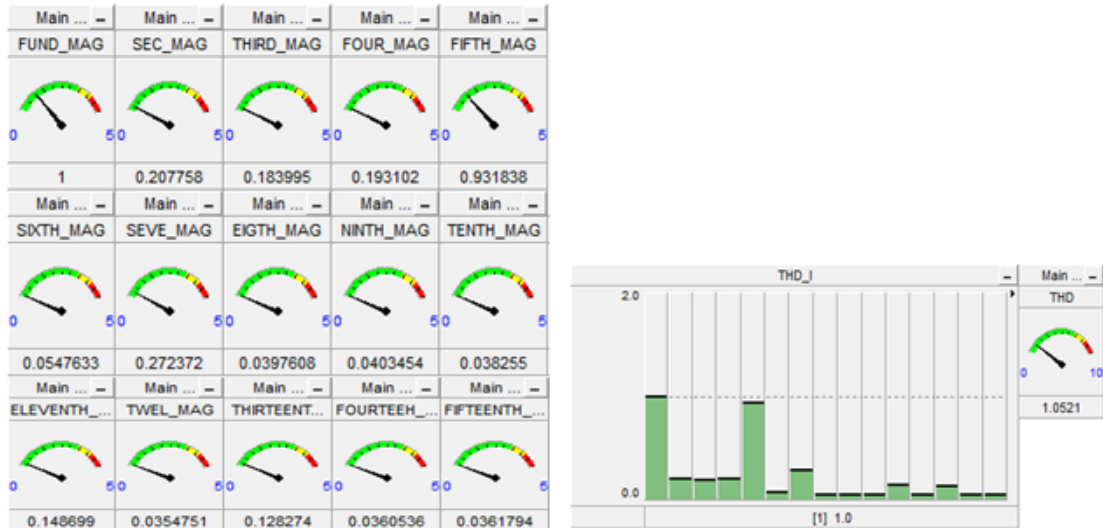

Figure 6.18: Harmonics in the system after switching capacitor bank two

### 6.5.3 After energizing both capacitor banks

Harmonics and the total harmonic distortion are then obtained from the simulation after energizing of the capacitor bank one and two. Figure 6.19 shows individual harmonic magnitudes and the table 6.8 shows the comparison between all the possible scenarios.



University of Moratuwa, Sri Lanka.  
Electronic Theses & Dissertations  
www.lib.mrt.ac.lk

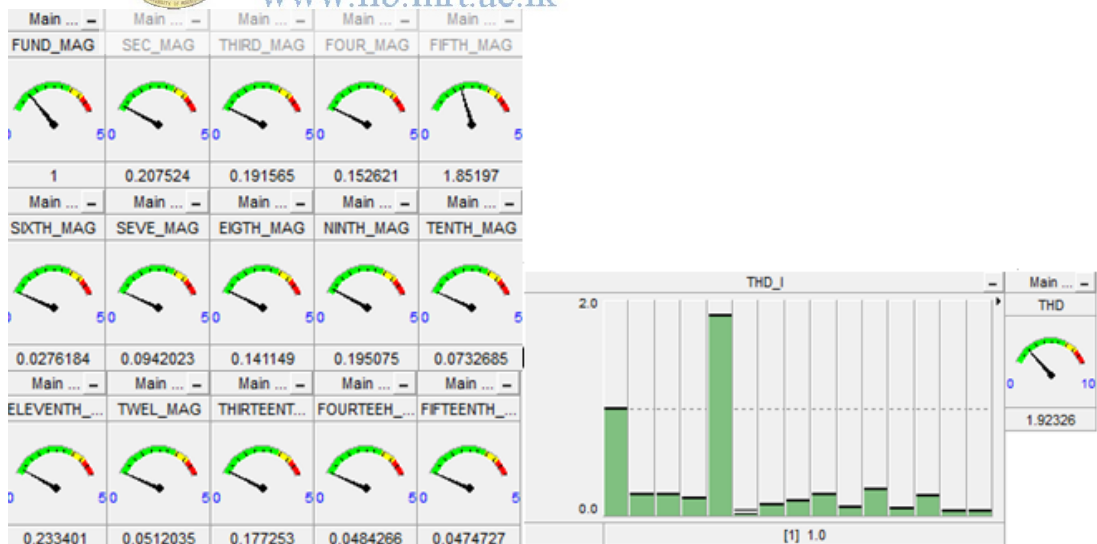

Figure 6.19: Harmonics in the system after switching both the capacitor banks

Table 6.8: Comparison of harmonic magnitudes with different capacitor energizing

Harmonic Order	Steady State	Energizing Cap Bank one	Energizing Cap Bank two	Energizing Both Cap Banks
01	100	100	100	100
02	25	24.5	20.7	20.7
03	20	19.6	18.4	19.1
04	15	14.6	19.3	15.3
05	200	186	93.2	185
06	10	9.1	5.4	2.8
07	100	97.5	27.2	9.4
08	10	9.4	3.9	14.1
09	9	8.8	4	19.5
10	8	7.9	3.8	7.3
11	30	29.6	14.8	23.3
12	7	6.9	3.5	5.1
13	25	24.4	12.8	17.7
14	7	6.8	3.6	4.8
THD	2.27	2.18	1.05	1.92

The 5<sup>th</sup> harmonic is more dominant as show in the figures after energizing both the capacitor banks and it is very much closer to the condition where no capacitor banks are switched to the system. The other dominant harmonic which is the 7<sup>th</sup> harmonic is almost eliminated when both the banks are switched on. The other harmonics are very much similar to the previous values. The total harmonic distortion is also 1.92.

### 6.6 Summery of analysis and results (for the model)

With the simulation results obtained from the study following conclusions can be done for the Thulhiriya substation.

- By considering the transient percentage from the steady state value, + or – 2 ms to the zero crossing point can be selected as the safe region for the switching of the capacitor bank
  - From the results obtained 130% of the steady state value is not showing much of an impact to the power quality
- Transients are within the acceptable limits as per IEEE Std 1036-2010. Typical levels of the voltage magnitude range from 1.2 to 1.8 per unit (peak phase-to-ground voltage) for substations
- As per the waveforms obtained switching of the Capacitor bank one produces higher transients than switching of Capacitor bank two
- In the case of back to back switching, switching of capacitor bank two and then capacitor bank one gives less effect to the waveform
- If the banks are switched in zero crossing then the switching sequence is immaterial.
- “NOVAR” controller at Thulhiriya GSS has no zero crossing detector. Has to embed a zero crossing detector for the controller for better power quality during switching of capacitor banks.
- During fast switching of both the banks
  - 30ms should be delayed in the switching sequence of capacitor bank one and capacitor bank two
  - 40ms should be delayed in the switching sequence of capacitor bank two and capacitor bank one
  - This delay should be followed for manual operations and also for delay settings in auto mode
- Since the “NOVAR” controller only corrects the power factor to a desired value, even if the Mvar requirement arises the capacitor banks will not be switched to the system. There for to maximize the utilization of the available capacitor bank it is suggested to have a module which takes the decision by combining the power factor and Mvar requirement of the system
- Energizing of capacitor bank one will not have much of an impact to the original harmonic level and THD in the system





- Energizing of Capacitor Bank two will drastically reduced the THD of the system and the more dominant harmonic level of 7<sup>th</sup> Harmonic
- After energizing both the banks the THD value will reduce and the 7<sup>th</sup> harmonic is almost eliminated
- Availability of capacitor banks will not have any effect to the 5<sup>th</sup> harmonic present in the system
- The THD level of the Thulhiriya GSS is within the acceptable limits even without the capacitor banks (As per IEC 61000-3-6 the THD value should be less than 6.5).
- By adding the capacitor banks the THD level can be further reduced.
- Addition of capacitor banks to the Thulhiriya 33kV bus does not provide any adverse effect to the existing system & well within acceptable limits as per the simulation
- By considering the switching transients & the THD the best sequence of energizing of capacitor banks would be capacitor bank two and then capacitor bank one
- Considering the obtained results it is recommended to switch on the capacitor banks at Thulhiriya GSS



## 7 Conclusions and recommendations

- Zero crossing point is the exact position for the breaker to be closed for the capacitor bank
- Even though the initial cost is high Embed a zero crossing detector module in every GSS capacitor controller to have good power quality during capacitor switching
- The fast switching should be avoided as much as possible
- If in case fast switching is done in auto mode a time delay should be introduced by studying the transients for the particular case
- If manual operation is doing a delay time should be introduced to the back to back switching by studying the transients
- When purchasing & specifying capacitor bank and harmonic filters
  - Consider the cost associated with nearby electrical equipment miss operation or damage should be evaluated against the cost of additional modules/ equipment to avoid/ reduce transients
- Most of the cases the capacitor banks are switched by considering only the power factor correction. In order to utilize the available capacitor banks it is vital to consider combination of PF correction, Mvar requirement & voltage
- Even PF correction & Mvar requirement is achieved it is not recommended to energized a detuning capacitor bank (bank feeder) first with the concern of transients and THD
- First energize the tuned capacitor bank (filter feeder) followed by the non-tuned capacitor (bank feeder) bank

Figure 6.20 shows the suggested method of actual implementation to the capacitor bank operation to minimize the transient effect to the system. A programmable logic controller should be embed to the remote terminal unit (RTU) for decision making. When the RTU decide the need of the capacitor banks to the system by considering power factor correction, Mvar requirement or voltage requirement, the PLC unit is activated for zero crossing detection by monitoring the 33 kV voltage. When the zero crossing is detected the PLC unit initiate an open/ close signal and send the

command to the circuit breaker to switch the capacitor bank on/ off via RTU. Then again the PLC unit measures the voltage in order to sense the transient voltage during the operation. If the detected transient is not within the predefined acceptable limit the timing of the initiation of the close/ open command should be delayed accordingly until the measured transients comes within the acceptable limit. However the initial breaker open/ close time delay should be introduced to the PLC unit by considering the circuit breaker closing and arcing time delay obtained from the circuit breaker tester (CBT 400 in the case study). This methodology can be explained from the flow chart as shown in the figure 6.21.

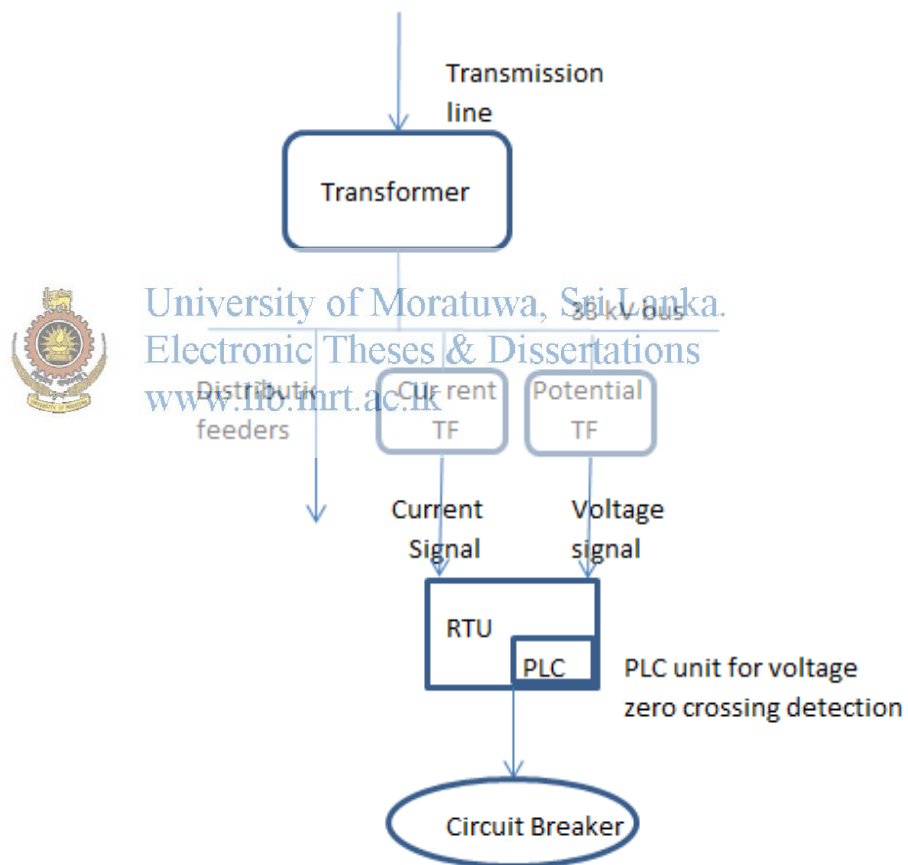

Figure 6.20: Implementation of RTU and PLC

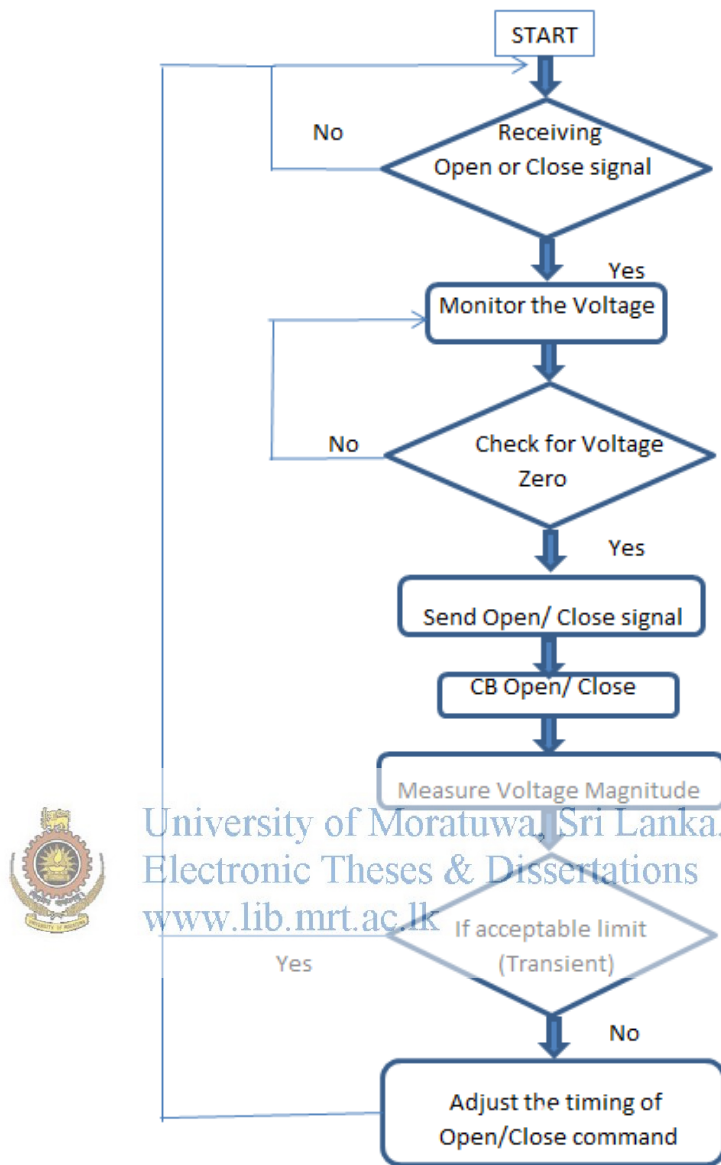



Figure 6.21: Flow chart

## References

- [1] Zbigniew Leonowicz “*Reactive power Compensation*”
- [2] Dixon J “*Reactive power Compensation Technologies, State of Art Reveiw*”.
- [3] “*CEB Statistical Digest-2011*”, Statistical Unit, Commercial & Corporate Branch, Distribution Region-3, PO Box 540, Colombo 02, Sri Lanka.
- [4] M.A.S. Masoum, M. Ladjevardi, A. Jafarian, M. Sarvi “*Application of Fuzzy Theory and Local Variations Algorithm for Optimal Placement of Capacitor Banks in Distorted Distribution Feeders*” Department of Electrical Engineering Iran University of Science & Technology Tehran, Iran, 168440
- [5] W.M.S. Deepika Wijesinghe “*Study of optimal location for capacitor installation in a 220/132/33 kV Grid Substation*” Department in Electrical Engineering, University of Moratuwa, February 2009
- [6] “*Power Factor Basics*” [www.iea-4e.org/document/43/power-factor-basics](http://www.iea-4e.org/document/43/power-factor-basics)
- [7] IEC 60871-1, “*Shunt Capacitor for a.c. power systems having a rated voltage above 1000V*”
- [8] IEEE Std. 18 “*2002 d for shunt Power Capacitors*”  

- [9] ABB “*Power Capacitor Units for improved power quality*”
- [10] Ceylon Electricity Board “*Specifications for CEB Grid Substations*” Section 6- Employer’s Requirement, Part B – Technical Specification
- [11] Grebe, T.E., “*Application of Distribution System Capacitor Banks and their Impact on Power Quality*”
- [12] Department of Electrical Engineering, University of Moratuwa, Sri Lanka “*Report on Failures in the MVar capacitor bank at Pannipitiya 220/ 132/ 33 kV Grid Substation*”
- [13] Silvio Segura, Ruben Romeo and Marcos J. Rider “*Efficient heuristic algorithm used for optimal capacitor placement in distribution systems*”
- [14] Durga Bhavani Mupperty “*Capacitor switching transient modeling and analysis on and electrical utility distribution system using simulink software*”.
- [15] Larry M. Smith “*A practical approach in substation capacitor bank applications to calculating, limiting, and reducing the effects of transient currents*”.

- [16] Siemens India “*Study Report –Pallekele GSS 20Mar BSC bay installation*”
- [17] Govind Gopakumar & Kalyan K Mustapi “*Shunt Capacitor Bank Switching Transients: A tutorial and case study*”
- [18] D.D. Magala, K Nareshkumar & K. Varatharaja “*Design of a VAR componsation for Pannipitiya GSS*”
- [19] J.C. Das “*Analysis and control of large shunt capacitor bank switching transients*”
- [20] ABB “*Capacitor, Detuned capacitor & filter bank products*”
- [21] Schneider Electric “*Power factor correction and harmonic filtering guide*”
- [22] Switching transient task force of the IEEE modeling and analysis of system transients working group “*Modeling guidelines for switching transients*”

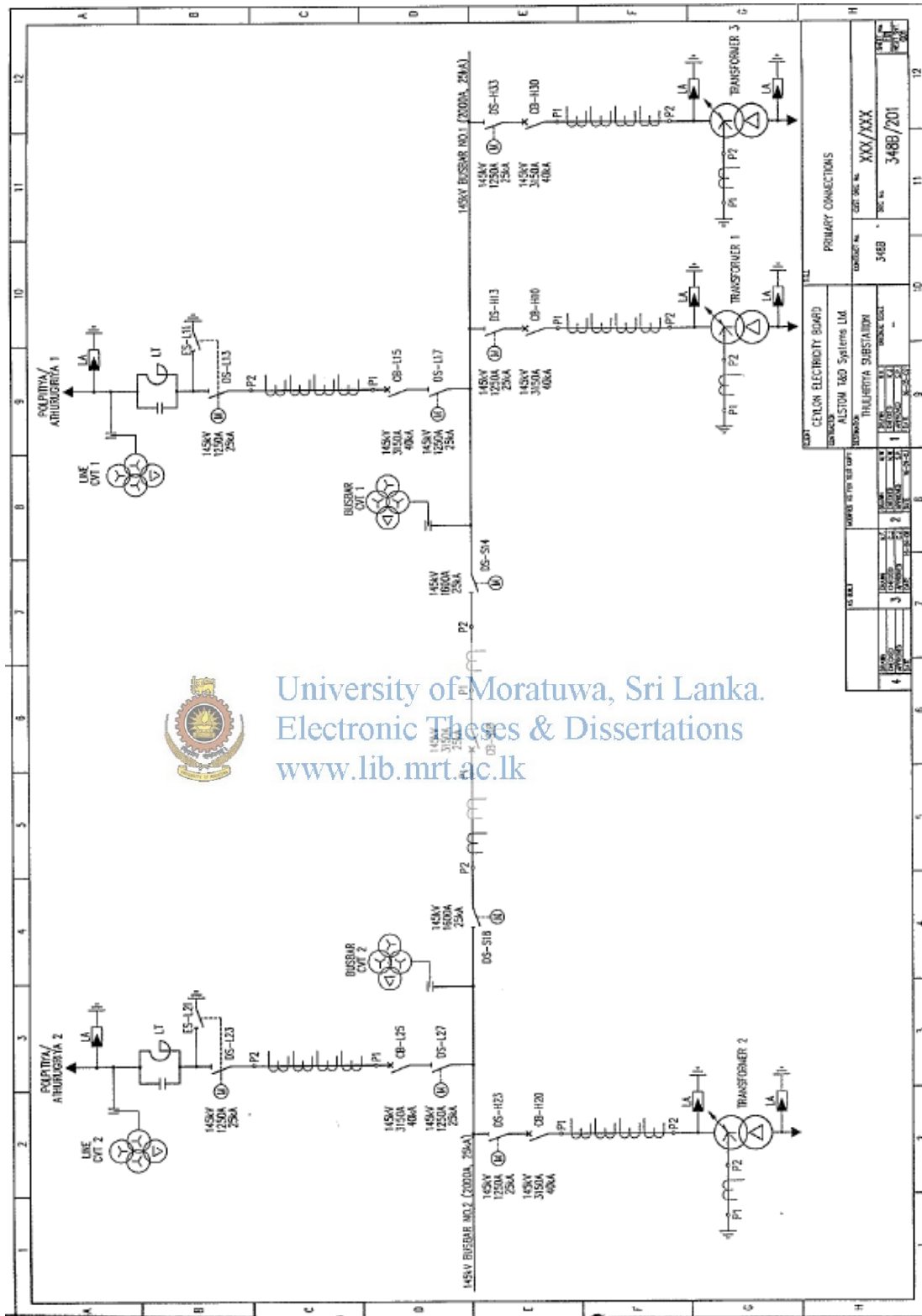

University of Moratuwa, Sri Lanka.  
Electronic Theses & Dissertations  
[www.lib.mrt.ac.lk](http://www.lib.mrt.ac.lk)

# Appendix 01: Single line diagram of Thulhiriya substation



University of Moratuwa, Sri Lanka.  
Electronic Theses & Dissertations  
[www.lib.mrt.ac.lk](http://www.lib.mrt.ac.lk)

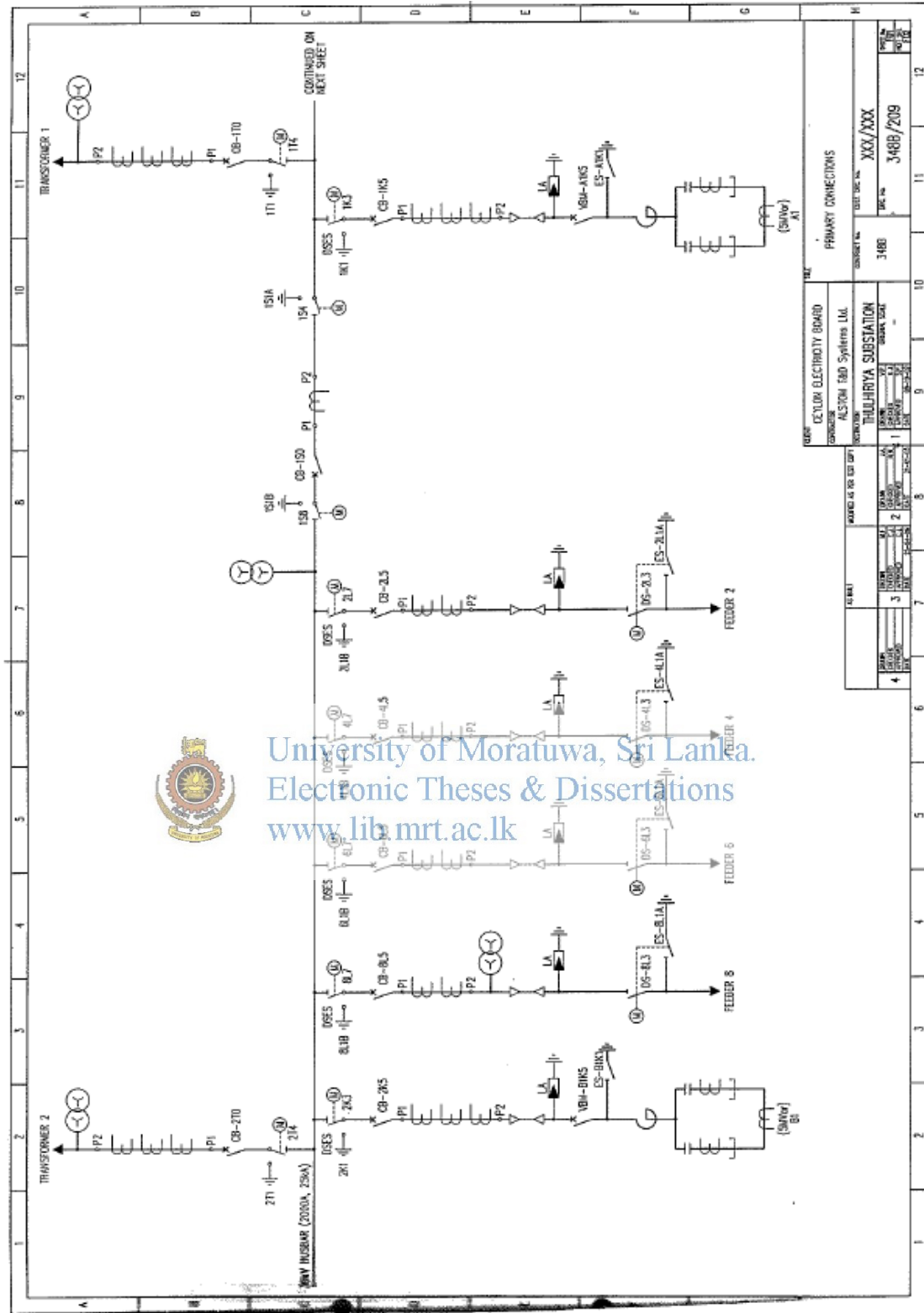

University of Moratuwa, Sri Lanka.  
Electronic Theses & Dissertations  
www.lib.mrt.ac.lk



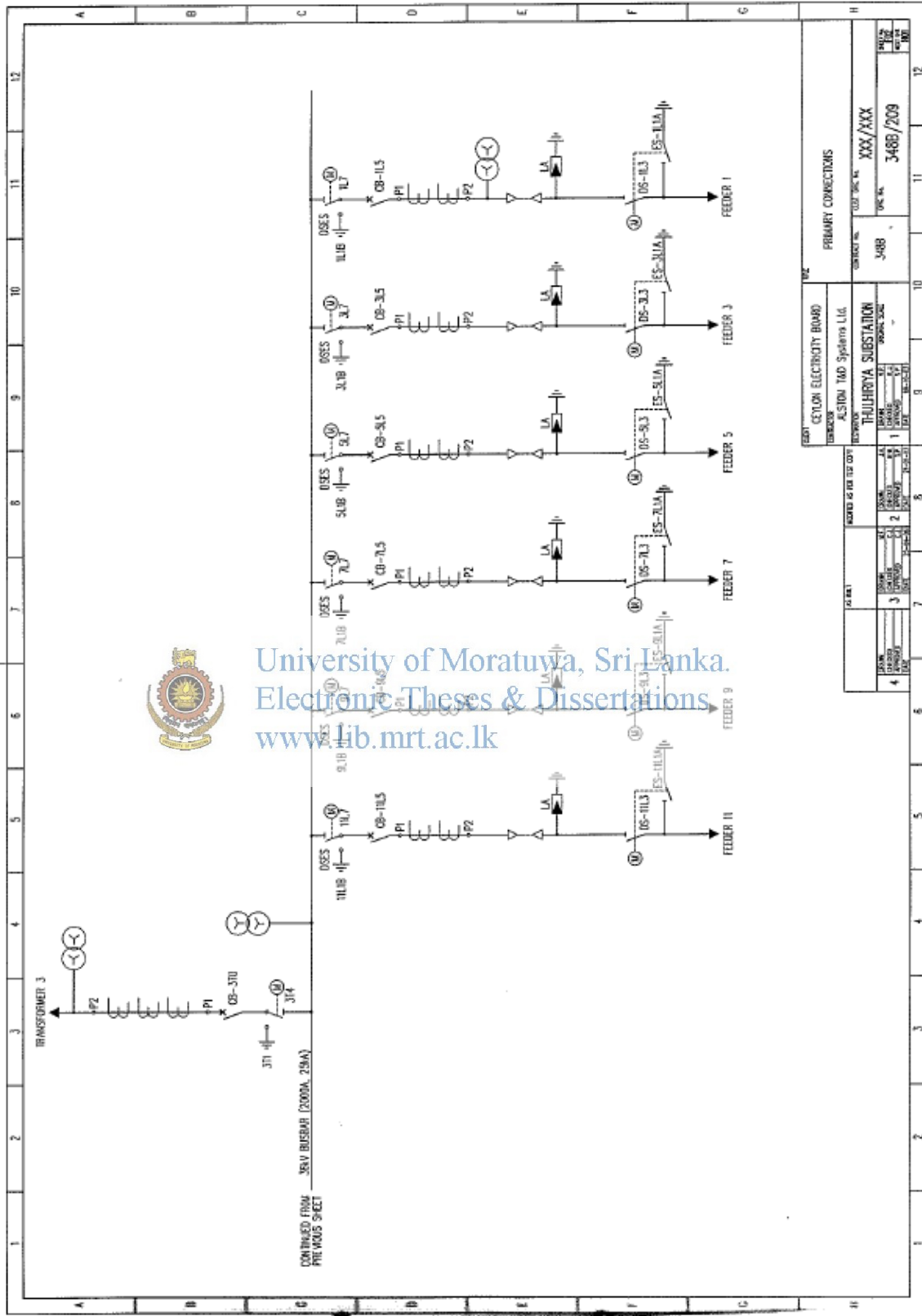

University of Moratuwa, Sri Lanka.  
 Electronic Theses & Dissertations  
[www.lib.mrt.ac.lk](http://www.lib.mrt.ac.lk)

<b>CEYLON ELECTRICITY BOARD</b> TRANSMISSION ALSTOM TAD Systems Ltd. <b>THURURIA SUBSTATION</b>		<b>PRIMARY DISTRIBUTION</b> CONTRACT NO. XXX/XXX SHEET NO. 3488/209	
DRAWN BY: [Blank] CHECKED BY: [Blank] DESIGNED BY: [Blank]	SCALE: [Blank] DATE: [Blank]	PROJECT NO.: [Blank] SHEET NO.: [Blank]	TOTAL SHEETS: [Blank]

## Appendix 2 : Technical Specification of 132 kV Areva Circuit Breaker

### 2 Technical Description

#### 2.1 Technical Data: Circuit Breaker

Type (see nameplate)		GL311- F1/4031/VR	GL312- F1/4031/VR
Rated voltage	kV	123	145
Rated normal current	A	3150	3150
Rated frequency	Hz	50/60	50/60
Rated power-frequency withstand voltage 50 Hz, 1 min			
– To ground	kV	230	275
– Across open switching device	kV	230	275
Rated lightning impulse withstand voltage			
– To ground	kV	550	650
– Across open switching device	kV	550	650
Rated switching impulse withstand voltage (Un > 245 kV)			
– To ground	kV	Not applicable	Not applicable
– Across open switching device	kV	Not applicable	Not applicable
Rated short-circuit breaking current			
– R.m.s. value of the a.c. component of current	kA	40	40
– Percentage of d.c. component	%	36	36
Minimum opening time	ms	35	35
First pole-to-clear factor		1.5	1.5
Rated transient recovery voltage			
– Peak value	kV	211	249
– Rate of rise	kV/ $\mu$ s	2.0	2.0
Short-line fault			
– Surge impedance	$\Omega$	450	450
– Peak factor		1.6	1.6
Rated short-circuit making current	kA	104	104
Rated out-of-phase breaking current	kA	10	10
Rated duration of short circuit	s	3	3
Rated operating sequence		O-0.3s-CO-3min-CO or CO-15s-CO	
Rated line-charging breaking current	A	31.5	50
Rated cable-charging breaking current	A	140	160
SF <sub>6</sub> weight per breaker	kg	12	12

r

## 2.2 Technical Data: Spring Operating Mechanism

Type (see nameplate)		FK 3-..
Motor for charging the closing spring:		
Rated voltage (preferred values)		
– Direct voltage	V	60/110/125/220/250 *)
– Alternating voltage	V	120/230 *)
Allowable rated voltage deviation		85 to 110 % Un
Power consumption	W	<750 **)
Closing spring charging time	s	< 15
Shunt releases, closing and opening:		
Rated supply voltage (preferred values only with direct voltage)	V	60/110/125/220/250 *)
Allowable rated supply voltage deviation		
– Shunt closing release		85 to 110 % Un
– Shunt opening release		70 to 110 % Un
Power consumption of releases		
– Shunt closing release	W	340
– Shunt opening release	W	340
Minimum pulse duration	ms	10
Auxiliary circuits:		
Rated continuous load current	A	10
Auxiliary contact tripping capability		
– At 230 V alternating voltage	A	10
– At 220 V direct voltage in an inductive circuit with a time constant of L/R = 20 ms	A	2
Anti-condensation heating:		
Rated voltage (alternating voltage)	V	120 or 230 *)
Power consumption	W	80

\*) Specify when ordering.

\*\*) The exact value is shown on the motor nameplate.



**Appendix 3 : Technical Specification of Alstom power transformer**

	<b>2. Technical Data</b>	Fb.Nr <b>316272</b> Sheet 1/3																																																
<p><b>2.01 <u>Rated power :</u></b>                  23 / 31,5 (ONAN / ONAF)</p> <p><b>2.02 <u>Power definition :</u></b>                  Design and power definition in line with IEC 76</p> <p><b>2.03 <u>Voltage and currents :</u></b></p> <table border="1" style="width: 100%; border-collapse: collapse; text-align: center;"> <thead> <tr> <th rowspan="3">Pos</th> <th colspan="3">HV</th> <th colspan="3">LV</th> </tr> <tr> <th rowspan="2">Voltages (V)</th> <th colspan="2">Currents (A)</th> <th rowspan="2">Voltage (V)</th> <th colspan="2">Currents (A)</th> </tr> <tr> <th>ONAN</th> <th>ONAF</th> <th>ONAN</th> <th>ONAF</th> </tr> </thead> <tbody> <tr> <td>1</td> <td>145 200</td> <td>91,5</td> <td>125,3</td> <td rowspan="3">33 000</td> <td rowspan="3">402,4</td> <td rowspan="3">551,1</td> </tr> <tr> <td>9</td> <td>127 600</td> <td>104,1</td> <td>142,5</td> </tr> <tr> <td>16</td> <td>112 200</td> <td>118,4</td> <td>162,1</td> </tr> </tbody> </table> <p><b>2.04 <u>Vector group symbol :</u></b>                  YNd1</p> <p><b>2.05 <u>Impedance voltage at 75°C :</u></b></p> <table border="1" style="width: 100%; border-collapse: collapse; text-align: center;"> <thead> <tr> <th>Pos.</th> <th>Base (kVA)</th> <th>Windings</th> <th>Impedance voltage (%)</th> </tr> </thead> <tbody> <tr> <td>7</td> <td>31 500</td> <td>HV / LV</td> <td>10,3</td> </tr> </tbody> </table> <p><b>2.06 <u>No - load losses :</u></b>                  15 200 W. (1,00 x Un)</p> <p><b>2.07 <u>Load losses at 75°C :</u></b></p> <table border="1" style="width: 100%; border-collapse: collapse; text-align: center;"> <thead> <tr> <th>Pos.</th> <th>Base (kVA)</th> <th>Windings</th> <th>Load losses (W)</th> </tr> </thead> <tbody> <tr> <td>7</td> <td>31 500</td> <td>HV / LV</td> <td>128 000</td> </tr> </tbody> </table>			Pos	HV			LV			Voltages (V)	Currents (A)		Voltage (V)	Currents (A)		ONAN	ONAF	ONAN	ONAF	1	145 200	91,5	125,3	33 000	402,4	551,1	9	127 600	104,1	142,5	16	112 200	118,4	162,1	Pos.	Base (kVA)	Windings	Impedance voltage (%)	7	31 500	HV / LV	10,3	Pos.	Base (kVA)	Windings	Load losses (W)	7	31 500	HV / LV	128 000
Pos	HV			LV																																														
	Voltages (V)	Currents (A)		Voltage (V)	Currents (A)																																													
		ONAN	ONAF		ONAN	ONAF																																												
1	145 200	91,5	125,3	33 000	402,4	551,1																																												
9	127 600	104,1	142,5																																															
16	112 200	118,4	162,1																																															
Pos.	Base (kVA)	Windings	Impedance voltage (%)																																															
7	31 500	HV / LV	10,3																																															
Pos.	Base (kVA)	Windings	Load losses (W)																																															
7	31 500	HV / LV	128 000																																															

All rights of this document are reserved to ALSTOM. To duplicate and to pass over to third persons without previous permission is forbidden. This document is subject to change ALSTOM 003

**2.08 Insulation level :**

Windings	Max. operating voltage Um (effective value) (kV)	Rated short duration power frequency withstand voltage AC (effective value) (kV)	Rated lightning Impulse Withstand voltage LI (peak value) (kV)
HV	145	230	550
HV-N	-	95	250
LV	36	70	170

**2.09 Frequency :**

50 Hz.

**2.10 On-load tap changer :**



Make : MR  
 Model : WLY 725B - Q183GR  
 Taps : +10% -15%  
 Taps range : +8% -9%  
 Number of steps : 200k  
 Rated through current : 200k

**2.11 Motor drive unit:**

ED 100 S

**2.12 Cooling method :**

ONAN / ONAF

**2.13 Temperature rise limits :**

Max ambient temperature : 40 °C  
 Top oil : 60 K.  
 Winding : 65 K.

**2.14 Setting of monitoring devices:**

*For oil temperature CT 031*

1.Gr Fan Stop : 50 °C  
 2.Gr Fan Stop I : 60 °C

Alarm : 79 °C  
Tripping : 89 °C

Winding temperature CT 033

1.Gr Fan Start : 70 °C  
2.Gr Fan Start : 80 °C  
Alarm : 94 °C  
Tripping : 104 °C

Winding temperature CT 034

1.Gr Fan Start : 70 °C  
2.Gr Fan Start : 80 °C  
Alarm : 95 °C  
Tripping : 105 °C

**2.15 Current transformer :**



University of Moratuwa, Sri Lanka.  
Electronic Theses & Dissertations  
[www.lib.mrt.ac.lk](http://www.lib.mrt.ac.lk)

T24:

Burden : 10 VA  
Class : 3  
Ratio : 700 / 2 A.

**2.16 Weights (kg):**

Total weight. : 59 500 kg.  
Transport weight(without oil) : 41 000 kg.  
Total weight of oil : 14 600 kg.  
Weight of active part : 31 500 kg.

Appendix 4 : 132 kV Conductor data sheet



**CONDUCTOR DATA SHEET**  
**ALUMINUM CONDUCTORS STEEL REINFORCED ( ACSR )**



Code Name	Nominal aluminium area		Equivalent copper area		Stranding and wire diameter			Overall diameter	Total area		Weights			Calculated breaking load		Maximum dc resistance at 20 °C
	mm <sup>2</sup>		mm <sup>2</sup>		mm		Steel mm		mm <sup>2</sup>		kg/km		kN		Ω /km	
	Aluminium	Steel	Aluminium	Steel	Aluminium	Steel		Aluminium	Steel	Aluminium	Steel	Aluminium	Steel	Aluminium		Steel
TIGER	125		80.7		30/2.36	7/2.36	16.52	30.62	161.8	362	240	602	58.0	0.2202		
WOLF	150		96.8		30/2.59	7/2.59	18.13	36.88	194.9	437	289	726	69.2	0.1828		
DINGO	150		97.9		18/3.35	1/3.35	16.75	8.81	167.5	437	69	506	35.7	0.1815		
LYNX	175		113		30/2.79	7/2.79	19.53	42.79	226.2	507	335	842	79.8	0.1576		
CARACAL	175		113.7		18/3.61	1/3.61	18.05	10.24	194.5	507	81	587	41.1	0.1563		
PANTHER	200		129		30/3.00	7/3.00	21	49.48	261.6	586	388	974	92.3	0.1363		
LION	225		145		30/3.18	7/3.18	22.26	55.60	293.9	659	436	1095	100.5	0.1212		
BEAR	250		161		30/3.35	7/3.35	23.45	61.70	326.1	730	483	1213	111.2	0.1093		
GOAT	300		194		30/3.71	7/3.71	25.97	75.67	400.0	896	593	1489	135.8	0.0891		
SHEEP	350		226		30/3.99	7/3.99	27.93	87.53	462.6	1034	684	1718	156.3	0.0770		
ANTELOPE	350		226		54/2.97	7/2.97	26.73	48.49	422.6	1032	379	1411	118.5	0.0773		
BISON	350		226		54/3.00	7/3.00	27	49.48	431.2	1056	388	1444	120.9	0.0757		
JAGUAR	200		130		18/3.86	1/3.86	19.3	11.70	222.3	580	91	671	46.6	0.1367		
DEER	400		258		30/4.27	7/4.27	29.89	100.20	529.8	1186	785	1971	178.5	0.0673		
ZEBRA	400		258		54/3.18	7/3.18	28.62	428.9	484.5	1186	435	1621	131.9	0.0674		
ELK	450		290		30/4.50	7/4.50	31.5	477.1	588.4	1318	872	2190	198.3	0.0606		
CAMEL	450		290		54/3.35	7/3.35	30.15	475.9	537.6	1314	483	1797	145.9	0.0607		
MOOSE	500		323		54/3.53	7/3.53	31.77	528.5	597.0	1462	537	1999	161.0	0.0547		

## Appendix 5 : Manual of Joslyn Circuit Breaker

**JOSLYN**

Joslyn Hi-Voltage Corporation  
4000 East 116th Street  
Cleveland, Ohio 44105

Telephone (216) 271-6620  
Fax (216) 341-3616

I. 750-310  
Revised September, 1995  
Supersedes May, 1992

# Model VBM Fault Interrupter

## Instructions

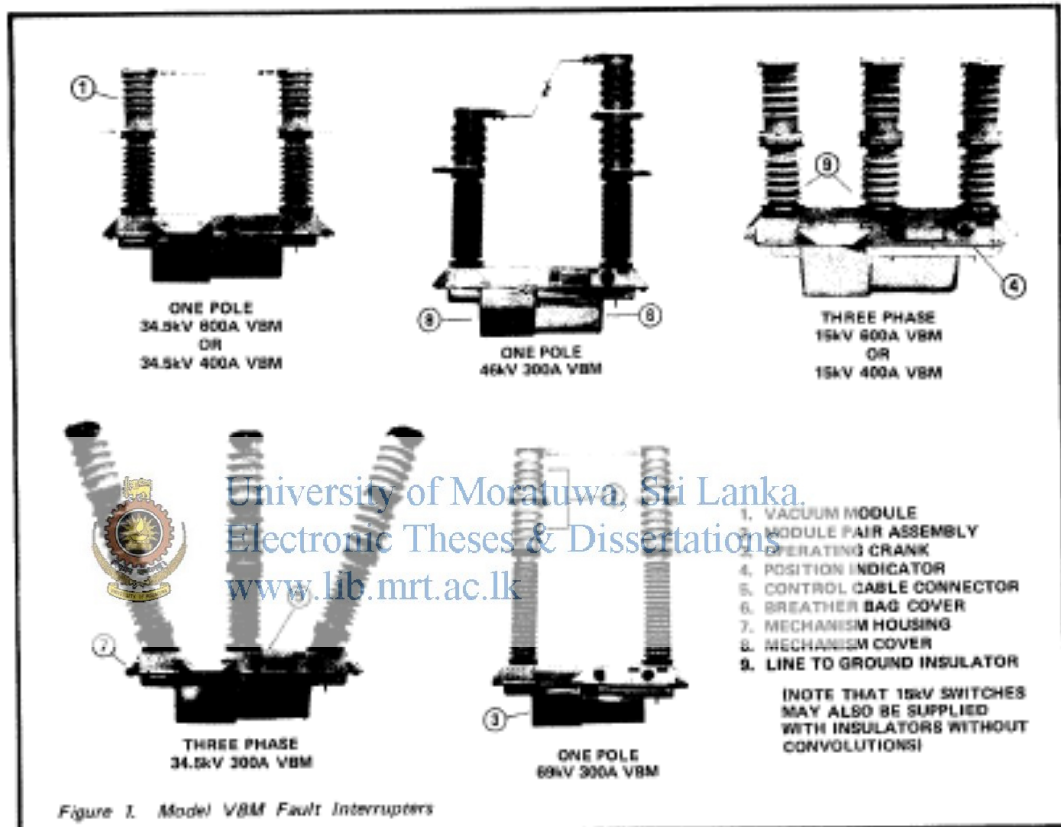

### Contents

#### General

1. Description
2. Servicing
3. Renewal Parts

#### Installation

1. Inspection and Uncrating
2. Mounting
3. Control Wiring
4. High Voltage Connections

#### Testing Vacuum Contacts

1. High Potential
2. Contact Resistance

### Servicing Procedures

1. Removal and Replacement of Housing Cover and Breather Bag
2. Removal and Replacement of a Module Assembly
3. Synchronization of Replacement Module Assembly
4. The Solenoid Operator
  - a. Solenoid Assembly Replacement
  - b. Wiring Harness and Auxiliary Switch Assembly Replacement
  - c. Auxiliary Switch Adjustment
5. Switches Rated 1,000 Amperes or Higher
6. The Motor Operator



## I. GENERAL

### 1. DESCRIPTION (Figures 1, 2, & 3)

The VBM Vacuum Interrupter is manufactured in voltage ratings from 15 to 69 kV with continuous current capabilities from 300 amperes. The mechanism may be operated manually, or electrically by solenoid or motor operators.

The assembly containing the vacuum interrupter is called a module (Figure 2). Each module has an interrupter contact (Figure 3) sealed in Joslyte, a solidified foam which provides mechanical strength, high dielectric strength and complete moisture sealing. The module housings are cycloolephetic or EPR rubber bonded to a fiberglass tube. One or two modules are mounted on each insulator and connected to the mechanism by a high strength pull rod.

The completely sealed operating mechanism housing supports line-to-ground insulators and the modules. An expansion bag in the housing prevents "breathing-in" contaminants or moisture and contains a desiccant package to maintain dry air.

All electrical control connections to the mechanism are made through a single environmental control cable connector.

An "Open-Closed" position indicator is directly coupled to the mechanism. A separate operating crank enables manual operation of the switch. The entire assembly can withstand several G's without damage. Depending upon rating there may be one or more mechanisms for a three phase switch.

### 2. SERVICING

Servicing of VBM switches is easily accomplished by referring to the appropriate section of these instructions. The following tools are required:

- 0 to 1.000" dial indicator, graduated in .001",
- Continuity lamps as required,
- 0-150 inch-pound torque wrench,
- Socket or wrench set,
- C-Clamp,
- 30kV AC High Potential Test Set.

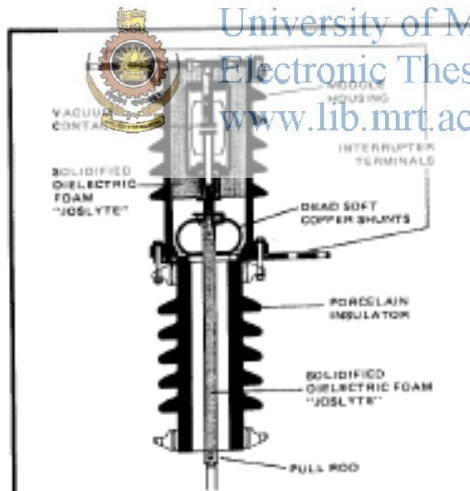

Figure 2. Cutaway drawing of single vacuum module on 15kV line to ground insulator.

## 3. REPLACEMENT PARTS

Replacement parts are stocked in Cleveland, Ohio. Furnish complete nameplate data and the Hi-Voltage Corporation G. O. Number, applying to the original purchase, along with description of the part and quantity required.

## II. INSTALLATION

### 1. INSPECTION AND UNCRATING

Carefully inspect the equipment on arrival and report any damage to the carrier, file a claim, and contact Joslyns for replacement parts and service.

Remove crating surrounding the VBM switch. Do not unbolt the switch from the wooden base. PERFORM HIGH POTENTIAL AND CONTACT RESISTANCE TEST DESCRIBED IN SECTION III, PRIOR TO PUTTING EQUIPMENT INTO SERVICE.

### 2. MOUNTING

Attach an erecting sling to each mechanism as shown in Figure 4. Make certain the lift is stabilized. Remove the three nuts holding VBM to the wooden base. Hoist the switch to its mounting with the manual operating handle facing the desired direction. Fasten the VBM to its mounting with three 5/8" bolts and remove the erecting sling. THE STRUCTURE AND VBM MECHANISM HOUSING MUST BE SOLIDLY GROUNDED.

### 3. CONTROL WIRING

Control power must meet the requirements of the drawing supplied with the switch.

All control connections are made through either of the following, depending on the switch:

- Environmental cable and connector. The cable may be shortened to desired length. Connection to the control en-

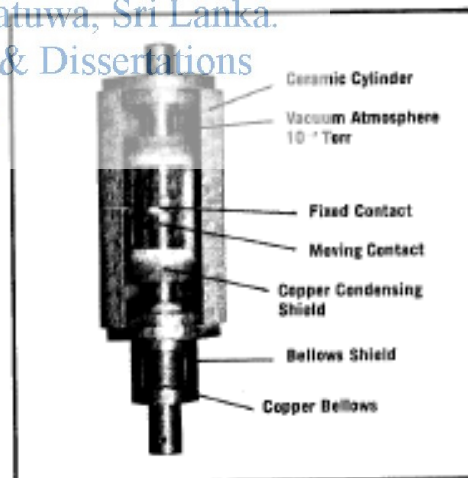
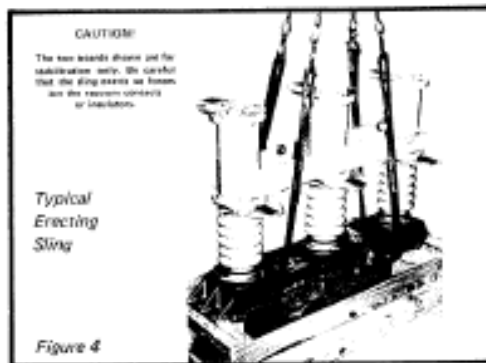

Figure 3. Cutaway photograph of vacuum contact. Moving contact separates 0.160" from fixed contact. Copper bellows preserves vacuum interrupting dielectric.



closure must be in accordance with the approved wiring diagram.

b. A NEMA 12 junction box mounted on the housing wired to the mechanism through conduit.

#### 4. HIGH VOLTAGE CONNECTIONS

The terminal pads are aluminum alloy with standard NEMA two-hole drilling. The electrical connection at the terminal pad must be treated with Alcoa No. 2 joint compound or equivalent. Wire brushing through the compound will improve the connection.

### III. TESTING AND EVALUATION OF VACUUM CONTACTS

Two tests may be performed to evaluate the vacuum contacts. They should be performed across each module separately. Figure 5 indicates connection point for single and double vacuum module assemblies.

#### 1. HIGH POTENTIAL

Low vacuum results in complete breakdown across an open contact at voltages below 30 kV RMS. Only AC high potential testing is recommended. AC testing is not used above 30 kV RMS across each individual contact for 15 seconds with the switch open. To avoid possible generation of X-rays, do not apply more than 30 kV RMS.

During the high potential testing, self-extinguishing, momentary breakdowns lasting only a few microseconds may occur. These "barnacles" are not significant but can result in false indication of vacuum loss, if the test set utilizes a high speed overload relay or breaker.

During normal operation with the switch in service, loss of vacuum or a defective switch module may be indicated by excessive radio noise with the switch open or observation of different surface temperatures of modules on the same switch. See Joslyn Engineering Memo T.D. 750-918.

#### 2. CONTACT RESISTANCE

With the switch closed, the resistance across each module should be less than 200 micro-ohms. On switches with modules connected in parallel for higher current operation, remove the connecting bus to perform this test. If higher resistance values are measured contact the Joslyn H-Voltage Corporation.

### IV. SERVICING PROCEDURES

#### 1. REMOVAL AND REPLACEMENT OF THE HOUSING COVER AND BREATHER BAG

Remove screws that hold the mechanism cover to the switch base. Care must be taken to keep the gasket and mating surfaces free of tool marks, scratches, scars, and foreign material. The valve stem protruding from the bottom of the mechanism housing should be kept sealed. It is intended only for leak testing during manufacture. The expansion chamber or breather bag is held by one bolt accessible from inside the mechanism cover. It may be removed or replaced by opening the closure plates or the separate breather bag cover added to switches supplied beginning 1982.

Before replacing the cover, clean and dry the gasket and mating surfaces. Apply silicone grease (Dow Corning DC III or equivalent) to mating surfaces and position gasket. A new or revitalized desiccant package should be placed in the operator cavity section of the cover. Secure the twelve cover screws torqued to 50 inch-pounds.

#### 2. REMOVAL AND REPLACEMENT OF A MODULE ASSEMBLY

##### A. REMOVAL

One or two modules are mounted on each insulator depending on switch rating. Module pair assemblies should not be separated in the field because special tools are required for assembly and adjustment. If one module of a module pair assembly is defective, the complete module pair assembly must be replaced.

To remove a module assembly, disconnect all power from the VBM and remove the mechanism cover. Disconnect pull rod from the switch mechanism by removing two bolts and washer plates (see Figure 6, Item 7). Remove four bolts at top of insulator and lift module assembly complete with lower terminal pad and pull rod from the insulator. Insulators may be removed by taking out four cap screws holding them to switch base.

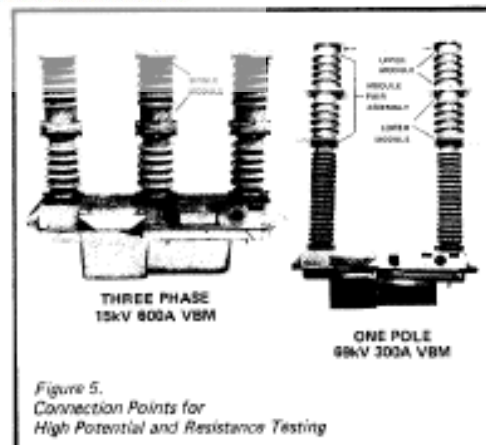

## B. REPLACEMENT

### 1. PREPARATION OF THE REPLACEMENT MODULE ASSEMBLY

Remove the bolts temporarily holding the lower terminal plate to single replacement modules. WITH THE BOLTS REMOVED, EXTREME CARE MUST BE USED NOT TO PUT ANY FORCE WHATSOEVER ON THE LOOSE TERMINAL PAD SINCE THIS FORCE WOULD BE DIRECTLY TRANSMITTED TO THE DELICATE BELLAWS OF THE VACUUM MODULES. ANY TWISTING COULD RESULT IN IMMEDIATE LOSS OF VACUUM. The double module assembly consists of two modules in series, an upper terminal plate and a lower terminal. It should not be disassembled. The single module and module pair assemblies are mounted in the same manner. An aluminum clevis link may be bolted in the mechanism end of replacement pull rods. If so, remove the aluminum clevis link and discard it. DO NOT attempt to replace the link already in the mechanism.

All single replacement modules are supplied with a separate "screw-on" pull rod. It is installed by slowly screwing onto the bolt in base of the module. Stop as thread bottoms to avoid putting any stress or strain on the vacuum contact. Back the rod off a maximum of one turn as required to mate with the clevis link on mechanism.

Earlier modules utilized either a permanently attached pull rod or a "screw-in" design. To replace a "screw-in" pull rod, slip the 1" nylon bushing supplied over the bolt end of the rod and slowly screw into the threaded module base. Stop as thread bottoms and back rod out approximately three full turns as required for proper orientation with mechanism.

Double module assemblies of the present design utilize a pull rod which is bolted to a draw bar in the lower module. All necessary hardware is supplied with replacement double module assemblies. The former design utilized a "screw-on" pull rod system.

All module assemblies are interchangeable and may be used on the same mechanism, regardless of type of pull rod, however using a present and former design double module pair assembly on the same mechanism requires special considerations. If this situation is required, contact the Joslyn III-Voltage Equipment Division.

**BUMPING OR DAMPING ANY PULL ROD WHEN ATTACHED TO A DOUBLE CLEVIS LINK OR THE VACUUM INTERRUPTER.**

### 2. MOUNTING THE REPLACEMENT MODULE ASSEMBLY

Apply silicone grease (Dow Corning DC III or equivalent) to all mating surfaces. Cork gaskets should be replaced. Rubber gaskets may be reused. Insert pull rod through insulator with module terminals in proper position. Fasten the replacement module to insulator with the  $\frac{1}{2}$ " bolts, nuts, and washers from the original module. Tighten the bolts evenly.

In mounting insulators and vacuum switch modules, particular attention should be paid to torque values. If a bolt head or nut bears on porcelain it should be torqued to 25 inch-pounds, otherwise torque to 50 inch-pounds.

With switch mechanism closed, attach pull rod to the steel clevis link of the mechanism with bronze bolts, nuts, lockwashers, and stainless steel washer plates placed outside the pull rod side pieces. Do not tighten the nuts to facilitate adjustment.

### 3. SYNCHRONIZATION OF REPLACEMENT MODULE ASSEMBLY (Figure 6)

Operation of a replacement module assembly must be synchronized with other module assemblies on the mechanism. Module pair assemblies are synchronized using the lower contacts only. Synchronization refers to the difference in over-travel of modules (or lower contacts of module pair assemblies) on the same operating mechanism. Although the actual over-travel measurement will be dependent upon the ambient temperature, synchronization is not affected by the ambient temperature.

a. Place the continuity lamps across all modules connected to line-to-ground insulators on the mechanism. DO NOT ATTEMPT TO SYNCHRONIZE A LOWER MODULE WITH AN UPPER MODULE ON A MODULE PAIR ASSEMBLY.

b. Attach a dial indicator (1) to the mechanism to measure vertical movement of the switch actuating bar. Joslyn recommends the dial gauge indicator be positioned against the bolt head as indicated by the arrows in Figure 6. It is shown out of position to enable photographing of other components.

#### c. CLOSED POSITION INITIAL REFERENCE

Put switch in closed position. The close stop (2) should be positioned so that toggle lines (3) are about one degree off vertical toward open position of the switch (see Figure 7 or 12 for solenoid or motor operators respectively). If adjustment is necessary, loosen the clamping bolts, reposition, and retorque to 120 inch-pounds. Adjust dial indicator to zero.

#### d. FULL TRAVEL

Put switch in open position. Dial indicator should read  $0.205" \pm 0.005"$ . If out of tolerance, adjust open stop (4). Retorque bolts to 120 inch-pounds.

#### e. OVERTRAVEL

With switch in closed position, slowly move the mechanism toward the open position with a  $\frac{3}{8}$ " wrench on a toggle link (3). Observe the dial gauge reading at which the continuity light(s) on the other module(s) goes out. This movement measured is the "OVERTRAVEL". At ambient temperatures between 50 and 80°F, the lights should go out at  $0.040" \pm 0.004"$  travel. Insert a spacer (5) between the close stop (2) and bumper (6) to hold the mechanism at a reading midpoint between open readings of the two other module assemblies on the mechanism. The spacer should be inserted on the opposite side from that shown in Figure 6. Torque the connecting bolts (7) on the replacement assembly pull rod to 75 inch-pounds.

#### f. SYNCHRONIZATION

Remove the spacer and close the mechanism. Slowly open the mechanism and observe the continuity lamps. Note the dial readings at which the replacement and adjacent modules open. The last lamp must go out within 0.005" mechanism travel after the first lamp. If synchronization is not achieved, loosen pull rod varying the "set" position in appropriate direction until all single or lower contacts open within 0.005" of mechanism travel.

g. After module pair assemblies have been synchronized using the lower contacts only, the synchronization between upper and lower contacts should be verified. The synchronization of upper and lower contacts is related to ambient temperature. At temperatures between 50°F. and 80°F. the dial gauge should measure a maximum of 0.010" travel of the actuating bar between the opening of each lower contact and its corresponding upper contact.

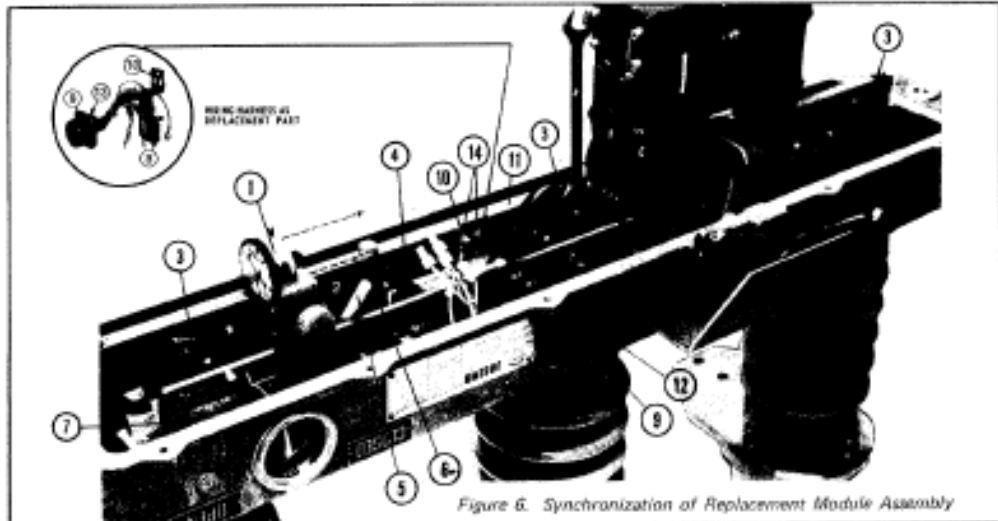

Figure 6. Synchronization of Replacement Module Assembly

#### 4. THE SOLENOID OPERATOR

In the single solenoid operator, two solenoids, one for opening and one for closing are used to move a toggle linkage over center releasing stored spring energy to open and close the vacuum contacts. This operation is sequentially described in Figure 7.

Some solenoid operators use a double solenoid assembly which utilizes two solenoids each for close and open operation. The operation and maintenance of the double solenoid operator is similar to that described for the single solenoid operator. The switch may be operated manually using a switch hook. An operating crank is located on the switch housing. The crank ends are notched to receive a switch hook. To close the interrupter, place the switch hook in the notch and pull the words "to close" and push. This moves the toggle linkage (14) to the closed position. To open the interrupter, place the switch hook in the notch and pull the words "to open" and push. This moves the toggle linkage (14) to the open position. To trip the interrupter, place the switch hook in the notch and pull the words "to trip" and push.

##### a. SOLENOID ASSEMBLY REPLACEMENT (Fig. 7)

Open splicing connectors on the four black solenoid wires. Leave black wires as long as possible. Remove two bolts (F) and the solenoid assembly is released. As the assembly is removed, the nylon actuating pins (G) will fall out.

One or both solenoids can be replaced by removing and replacing the appropriate bolts holding the assembly together. All bolts should be torqued to 70 inch-pounds.

To remount the solenoid assembly, insert nylon actuating pins and position the assembly. Torque two mounting bolts (F) to 200 inch-pounds. Connect the four black solenoid coil leads to corresponding wires using new insulated compression splices.

To insure operating components freedom of movement necessary to achieve proper operation speed, use a feeler gauge to check that end play of each actuating pin should be between .070 and .090". Manually

change switch position to check other pins. End play is adjusted by adding or removing flat washer shims (H) under nylon spacer sleeves.

##### b. WIRING HARNESS AND AUXILIARY SWITCH ASSEMBLY REPLACEMENT (Figure 6)

The auxiliary switch (8) and cable connector (9) are integral parts of the wiring harness assembly. The entire assembly must be removed as a unit. Open splicing connectors on the four black solenoid wires. Remove the auxiliary switch bracket (10) from the support bar (11). Remove four screws (12) which hold the environmental control cable connector and pull wiring harness assembly out of housing.

To install wiring harness, clean surfaces of casting where connector mounts. Apply a small amount of silicone grease (Dow Corning DC III or equivalent) to gasket (13) of new connector. Install wiring harness assembly, remount and adjust the auxiliary switch and rewire.

##### c. AUXILIARY SWITCH ADJUSTMENT (Figure 6)

With mechanism in closed position, use a C-clamp to hold the operating crank to its cover, so the crank cannot move from the closed position. Attach dial indicator (1) and set at zero. With a wrench on toggle link (3) move the mechanism toward the open position. The auxiliary switch (8) should operate at or before .175" vertical movement is indicated. Slowly return mechanism to closed position. The auxiliary switch should operate before the mechanism has returned to within .025" of the fully closed position. If adjustment is not correct, release bolts (14) and reposition bracket in appropriate direction. Retighten the bolts and recheck operation. Repeat until auxiliary switch operations occur within the allowable range. Tighten bolts to 70 inch-pounds. If proper adjustment cannot be achieved, replace wiring harness and auxiliary switch as directed per instructions.

#### 5. SWITCHES RATED 1,000 AMPERES AND HIGHER

These switches utilize modules connected in parallel. For some ratings more than one mechanism per pole is used. They

are installed per instructions in Section II and connected per Hi-Voltage Corporation drawings and control schematic for the particular switch.

All servicing and testing is performed on separate mechanisms by removing the connecting bus and referring to the appropriate section of these instructions.

### 6. THE MOTOR OPERATOR

A series motor drives a cam which loads a spring assembly. When the springs are fully loaded, the cam releases a linkage closing the vacuum switch using one-half the energy in the spring assembly. A low energy solenoid releases the remaining energy in the spring assembly through the same linkage to open the interrupter. Operation is sequentially described in Figures 8 through 11. The design inherently prevents closing the switch, unless sufficient energy to trip is stored in the spring assembly.

The VBM motor operator is designed to operate at 24VDC, 48VDC, 125VDC, or 120VAC depending upon application.

The switch may be operated manually using a switch hook. An operating crank is located on the switch housing. The crank ends are notched to receive the switch hook. To close The Fault Interrupter, place a switch hook in the notch above the words "Push to Close" and pump. After approximately 25 strokes, the switch will close. A unique rotary clutch allows strokes of any length to rotate the cam. A single swift push in the notch above the words "Push to Open" will trip the switch. Vacuum contact operating speed is independent of speed of manual activation.

The motor operator consists of a mechanical energy storage assembly and a control assembly. The control assembly is located in the base of the VBM switch. Connections to external circuitry are made through a control cable with environmental connectors.

### 1. ELECTRICAL

- Control Assembly (Figure 15):** Remove entire control assembly (A), by removing the mounting nut (B) and disconnecting cable shield (C), and install new control assembly.
- Replace and connect auxiliary switch(es) (D):** Move leads from terminals of auxiliary switch(es) (D). Remove screws (E) which hold the environmental connector (F) and pull wiring harness (G) out of the housing. To install wiring harness (G), clean surfaces of casting where connector mounts. Apply a small amount

of silicone grease to gasket of new connector. Install new harness (G) and rewire.

- Auxiliary Switch(es) (D) (Figure 8):** Replace by removing leads and two mounting screws.
- Replace auxiliary switch assemblies and actuating rod. With mechanism in open position set clearance between auxiliary switch mounting bracket and actuating bar at .125" to .132". (Note location of the mounting bolts.)
- With mechanism in closed position, use a C-clamp to hold the operating crank to its cover, so the crank cannot move from the closed position, attach dial indicator (1) and set to zero. With a wrench on toggle link (3) move the mechanism toward the open position. The auxiliary switch contacts should change state at or after .040" vertical movement is indicated. Slowly return mechanism to closed position. The auxiliary switch contacts should change state before the mechanism has returned to within .040" of the fully closed position. Auxiliary switch should have a .020" min. overtravel. (Ref. Figure 6).
- If adjustment is not correct, release bolts (14) and reposition brackets in appropriate direction. Retighten bolts and recheck operation.
- Repeat until auxiliary switch operations occur within the allowable range. Tighten bolts to 20 inch-pounds.
- Reconnect leads.

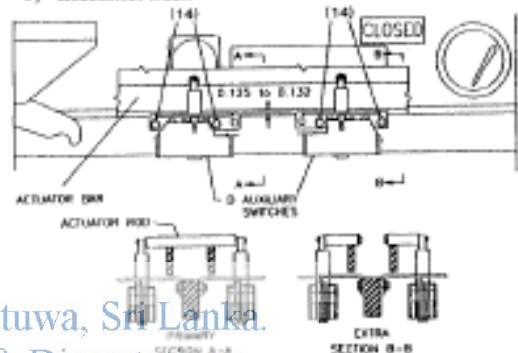

Figure 8

Note: An obsolete auxiliary switch (As noted by observing a metal pin actuator through the actuator bars to the auxiliary switches) can be replaced as described above. However, the old metal pin actuators must be cut as shown in Figure 9, for removal.

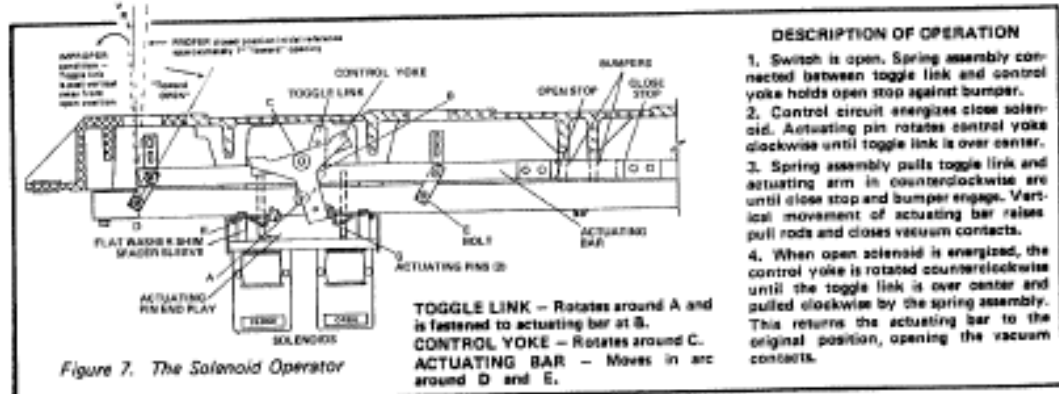

Figure 7. The Solenoid Operator

### DESCRIPTION OF OPERATION

- Switch is open. Spring assembly connected between toggle link and control yoke holds open stop against bumper.
- Control circuit energizes close solenoid. Actuating pin rotates control yoke clockwise until toggle link is over center.
- Spring assembly pulls toggle link and actuating arm in counterclockwise arc until close stop and bumper engage. Vertical movement of actuating bar raises pull rods and closes vacuum contacts.
- When open solenoid is energized, the control yoke is rotated counterclockwise until the toggle link is over center and pulled clockwise by the spring assembly. This returns the actuating bar to the original position, opening the vacuum contacts.



Figure 9

If necessary bend cranks (springs, 1/2" back from end and perpendicular to bottom edge). Care must be used when bending cranks to prevent twisting. Cranks must have full engagement with actuator at all times. (Springs can be bent in assembly).

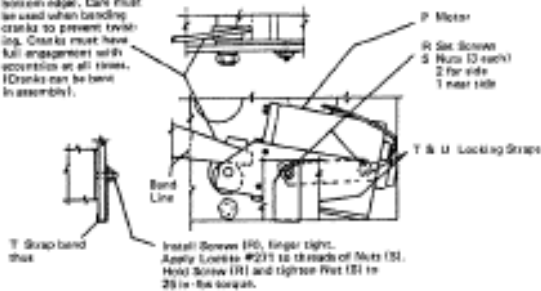

Figure 10

#### d. Motor

Not all motors are identical. When ordering replacement motors, the catalog number from the VBM nameplate must be supplied. New control panel may be required for obsolete motors.

- 1) Remove two set screws (H) if present.
- 2) Disconnect push-on connectors of motor leads from relay.
- 3) Deform locking strap (I) and remove two bolts (J).
- 4) Remove motor (K).
- 5) Install motor (P) using set screw (R).
- 6) Install locking straps (T&U) and nuts (S) using Loctite #271 on threads.
- 7) Bend bottom of locking strap (I) to fit.
- 8) Bend top cranks as necessary to fit (I) if necessary.
- 9) Connect push-on connectors of motor leads to relay.



University of Moratuwa, Sri Lanka.  
Electronic Theses & Dissertations  
www.lib.mrt.ac.lk

## 2. MECHANICAL

If a malfunction of the motor operator linkage occurs, replace the entire operator assembly (Figure 16). Two spring compressor devices are needed to hold and relieve pressure from the two main spring assemblies (S1 in Figure 4). Figure 16 shows where motor operator assembly is attached at points (L), (M) and (N).

- a. Detach Control Assembly as explained in Section 1.a.
- b. Remove two cotter pins (not shown) holding pin (M). Remove pin (M).
- c. Remove Set-Lock pins in holds (L) and (N) by driving them with an appropriate rod.
- d. Install new motor operator in reverse order. Re-use Set-Lock pins.
- e. Adjust the motor operator as required.
- f. Verify position of the "close" and "open" stops of the VBM per Section 3, with special attention to the "closed position initial reference".

- g. Adjust main operating lever assembly stops of motor operator assembly (Figure 15). With VBM fault interrupter in the closed position, the pin "R" (Figure 13) should turn freely. There should be no contact between the pin "R" and the stops. A separation of  $0.015" \pm 0.005"$  between the pin "R" and the bolt heads should be achieved by adjusting the bolts. The separation should be equal on both sides so that symmetrical forces are imparted to the motor operator assembly as the VBM fault interrupter is opened.
- h. Adjust toggle link assembly stop (Figure 13) as follows:
  - 1) Close VBM fault interrupter.
  - 2) Verify proper "closed position initial reference" is achieved, see Section 3, paragraph C.
  - 3) Screw in toggle link assembly stop Q until VBM fault interrupter trips.
  - 4) Back the screw 1/2 turn.
  - 5) Close the VBM fault interrupter. Unit should not trip free. If it does, back screw out an additional one-fourth turn.
  - 6) The screw Q should not be backed out more than one turn from the reference point at which the VBM fault interrupter trips, as described in step (2) above.
  - 7) After proper operation has been achieved, apply "C" grade Loctite to fix screw setting and tighten locking nut.
  - 8) Verify that operation of all vacuum modules are synchronized per Section 3.

## V. RECLOSING OPERATOR

VBM Fault Interrupters furnished with the Reclosing Operator are typically applied for breaker applications where both high speed reclosing and minimum interrupting time are the most significant requirements. The Reclosing Operator does not require periodic lubrication or adjustment. Contact the Customer Service Section at the Hi-Voltage Equipment Division for assistance.

Figures 11, 12, 13 and 14  
MOTOR OPERATOR

DESCRIPTION OF OPERATION

Figures 11, 12, 13 and 14 illustrate sequential operation of the assembly. The motor operator lever is connected to the switch actuating bar at point M. The actuating bar linkage is connected to the pull rods (not shown) of each module assembly.

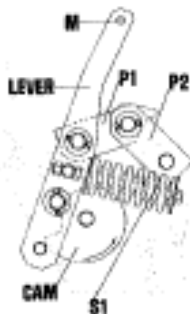

1. Switch is open.
2. Toggle links P1 and P2 are in retracted position.
3. Spring assembly S1 is compressed.
4. Cam is rotated counter-clockwise by manual operation.



Figure 11

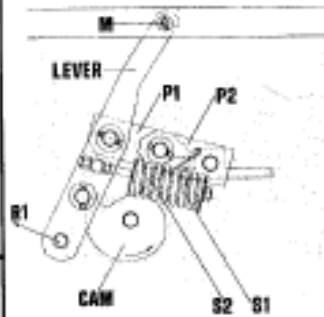

5. Lever is displaced in direction R1.
6. Spring assembly S1 is compressed storing energy in springs.
7. Lever pulls toggle links P1 and P2 over center.
8. Toggle spring S2 brings toggle linkage in extended position against stop.
9. The switch is open and the mechanism is ready to close.

Figure 12

10. As spring assembly S1 is fully loaded the cam releases lever and stops.
11. Lever pivots around fulcrum T. Pin R moves in arc R2 and comes against motor assembly chassis stop using 1/2 total energy in spring assembly S1.
12. M is moved in arc M1. M's displacement moves the switch actuating bar and closes the interrupter contacts.

Figure 13

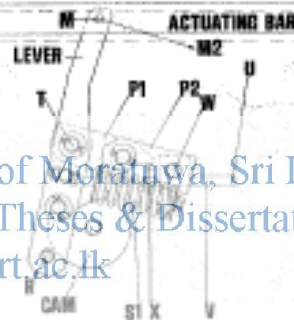
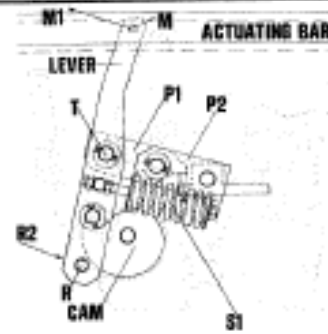

13. Switch is closed.
14. Solenoid exerts force U on lever V which pivots on fulcrum W exerting force X on toggle linkage P1 and P2.
15. Toggle link assembly is displaced. The remaining 1/2 total energy S1 pulls lever which pivots on fulcrum R. M moves in arc M2 moving switch actuating bar and opening contacts.
17. The switch is open.

Figure 14

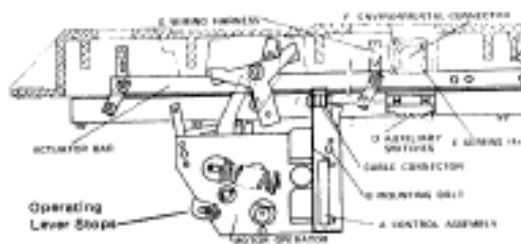

Figure 15 Mechanism Housing with Motor Operator

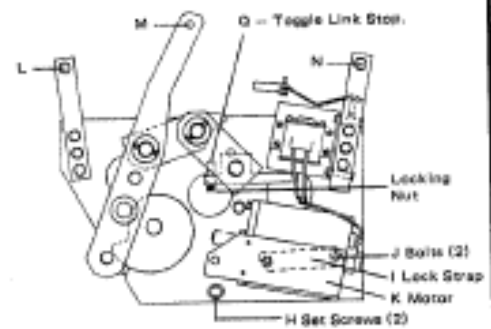
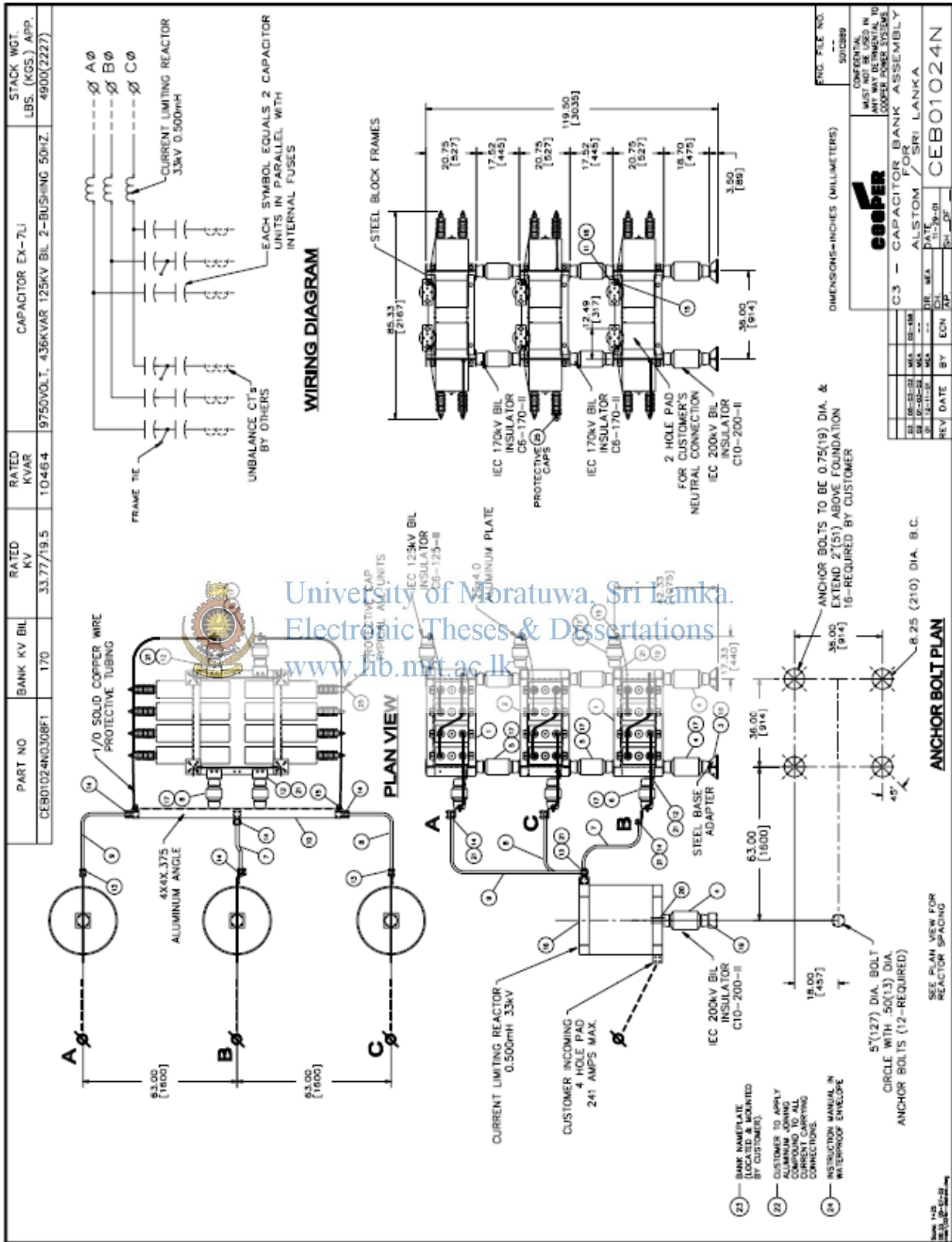

Figure 16 Motor Operator

## Appendix 6 : Installation of capacitor bank at Thulhiriya GSS





## Appendix 7 : Technical Specification of Novar 300 Controller

### 2. TECHNICAL SPECIFICATION

#### 2.1 RATINGS, OPERATING RANGES & FEATURES

<b>Voltage Rating (Vn)</b>	110 V, 120 V, 415 V, 480 V. Others available in range 63.5 V to 500 V max.
<b>Current Rating (In)</b>	1 A or 5 A. Others available in the range 0.5 A to 5 A max.
<b>Input Connections</b>	IA, VBC, or IB, VCA or IC, VAB IR, VYB, or IY, VBR or IB, VRY, IR, VST, or IS, VTR or IT, VRS.
<b>Line Current Transformers</b>	Class 1, 5 VA
<b>Operating Ranges</b>	
Voltage	85 ... 110 % Vn
Current	0... 120 % In
Frequency	50/60 Hz
Humidity	0...93 % +2 % -3 % Relative (non-condensing)
<b>Temperature Range</b>	Storage: -40... 80° C Operating: -10... 55° C
<b>Settings</b>	c/k 0.03... 1.00 cos phi 0.80... 1.00, 0.95 leading
<b>Overload Ratings</b>	1.5 x In for 10 seconds 2 x In continuously 20 x In for 3 seconds
<b>Isolation</b>	The controllers will withstand: 2 kV rms, 50/60 Hz for 1 minute between: - all terminals to case - current terminals to all others - voltage terminals to all others - output contact pairs (Volt Free versions)
<b>Impulse Voltage Test</b>	The controller will withstand: 5 kV 1.2/50 us, 0.5J, to BS923 and IEC 255-22-1 between: - all terminals and case - current input terminals - voltage input terminals - output contacts (open) - any pair of independent circuits
<b>Output and Alarm contact rating</b>	Make 1250 VA, 500 V a.c. resistive Carry 5 A a.c. Break 5 A a.c. Type: one normally open



## 2.1 RATINGS, OPERATING RANGES & FEATURES (cont.)

<b>No-volt release</b>	All output contacts are disabled within 15 ms. After the supply voltage is restored, normal operation is resumed, and the outputs are energised in sequence after the appropriate safety lockout time has elapsed.
<b>Burdens</b>	Current circuit: 0.2 VA at $I_n$ Voltage circuit: 9 VA (6 stages energised) 15 VA (12 stages energised)
<b>Net weight</b>	All models: 1.5 kg
<b>Terminals</b>	Barrier type: M3.5 Plug-in wire size: 1...2.5 mm <sup>2</sup> (18...14 AWG)
<b>Switching style</b>	Rotational or linear (see Figure 3). Selected at time of order. Rotational switching evens the contactor wear (for the largest step size only) and generally reduces the system response time. It is implemented for all sequences on NOVAR 300, if requested.
<b>Intelligent switching</b>	If twice the minimum capacitor size (or more) is required, then the NOVAR will switch in a double step. This applies for all sequences. For sequence 00 (1:1:1:1), the second capacitor will be connected after an additional delay of two seconds.
<b>Limit selection</b>	Up to 12 plus alarm output. The maximum possible for any configuration is determined by the number of relays fitted and the selected sequence. If the selected value is too high, the unit will automatically override it to the highest allowable value.
<b>Safety lockout</b>	The time required to safely discharge a capacitor can be set to any of 8 different values. The NOVAR will not allow any capacitor to be re-energised until this time has elapsed.  Providing that the safety lockout time has passed, the capacitor can be called after one fifth of the programmed time. It is not possible to override this lockout time.



## 2.1 RATINGS, OPERATING RANGES & FEATURES (cont.)

### Exit from manual

The AUTO/MAN button allows the user to switch between automatic and manual operating mode as required.

To safeguard against leaving a system indefinitely in manual mode, an automatic exit has been included. This will return the operating mode from manual to automatic five minutes plus the selected safety lockout time after the last manual mode operation. Relevant manual mode operations are pressing the lower button and operation of an output relay.

Models without the automatic exit from manual are available.

### Alarm output

Signals failure to meet target  $\cos \phi$   
See also Self Test

### Self Test

At reset and every ten minutes in operation, the NOVAR executes an internal hardware check for correct functioning. During this process, the model number will be displayed.

If the unit fails this self test, the IND and CAP LEDs are toggled and the alarm relay (if fitted) is also "flashed" in time with this.

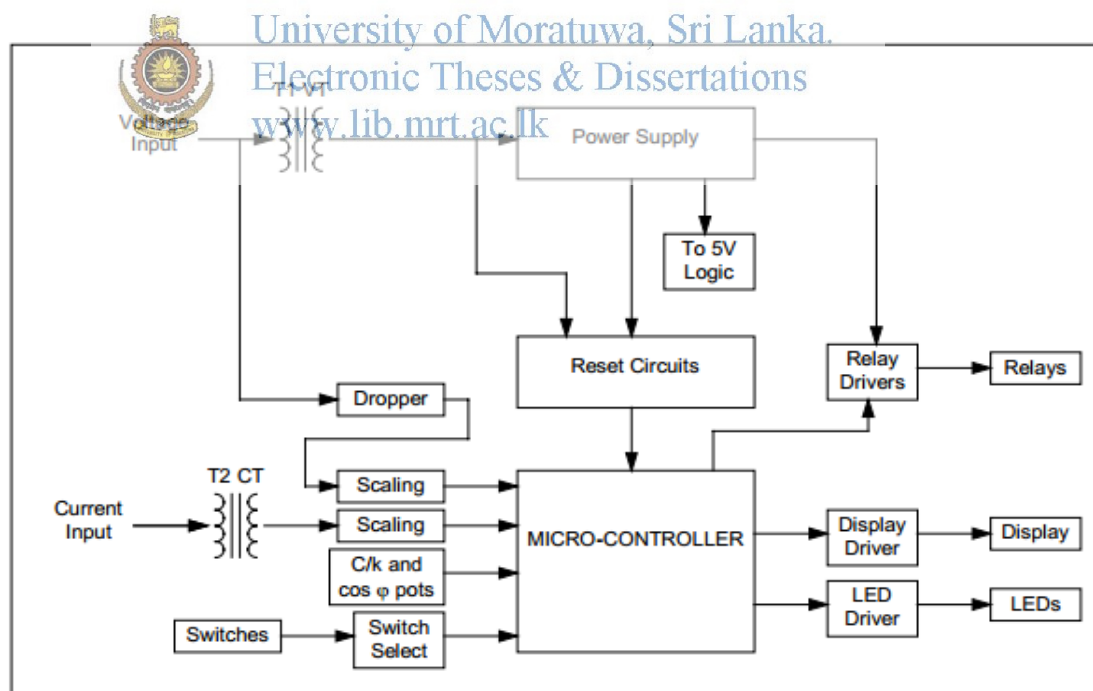

**NOVAR 300 Block diagram**

## Appendix 8 : Waveforms obtained for model validation

Simulated 33 kV bus voltage waveform for two our intervals on 18<sup>th</sup> October 2013

02.00 hr

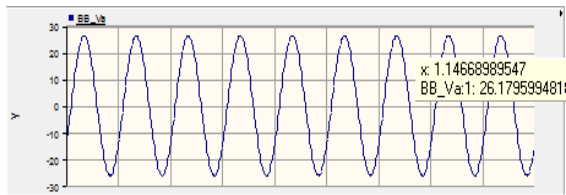

04.00 hr

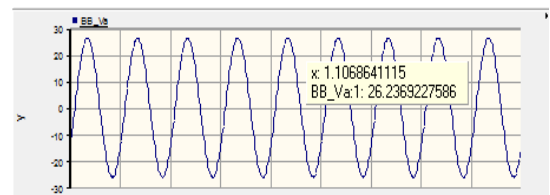

06.00 hr

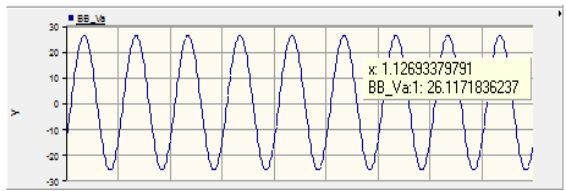

08.00 hr

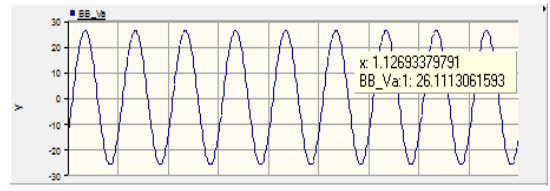

10.00 hr

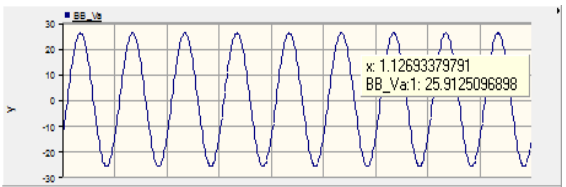

12.00 hr

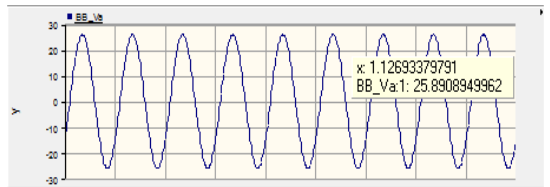

14.00 hr

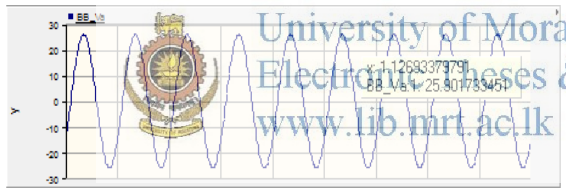

16.00 hr

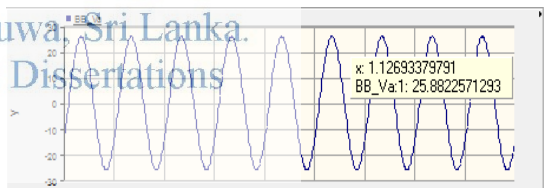

18.00 hr

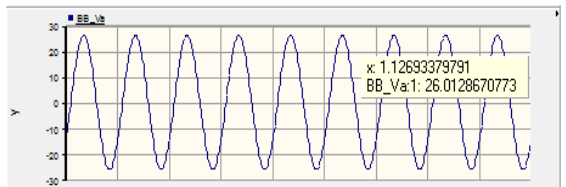

20.00 hr

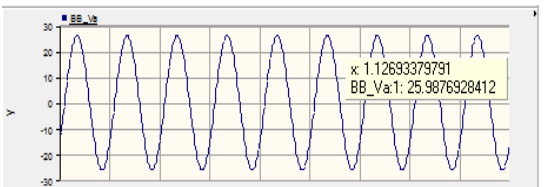

22.00 hr

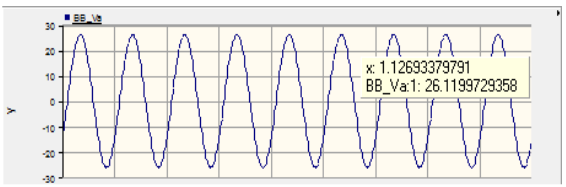

24.00 hr

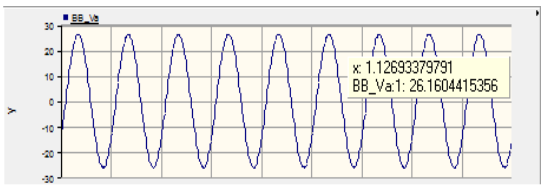

## Appendix 9 : Simulated waveforms for capacitor bank one closing

Zero Crossing

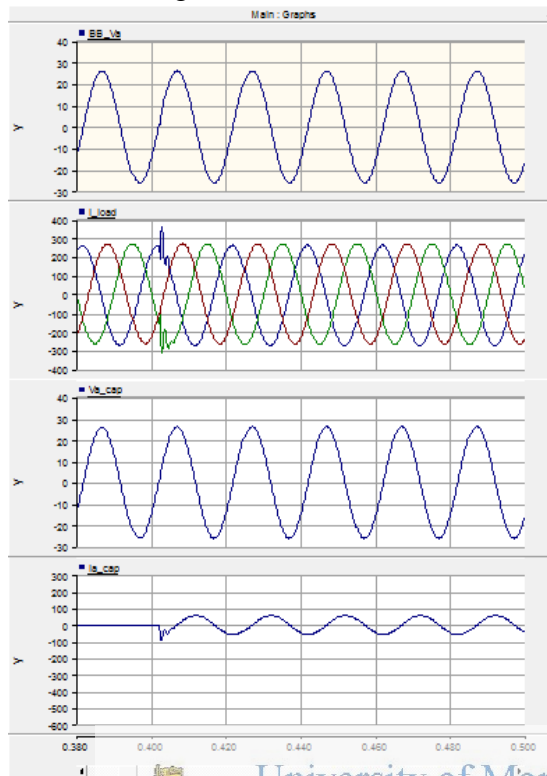

Zero Crossing+1ms

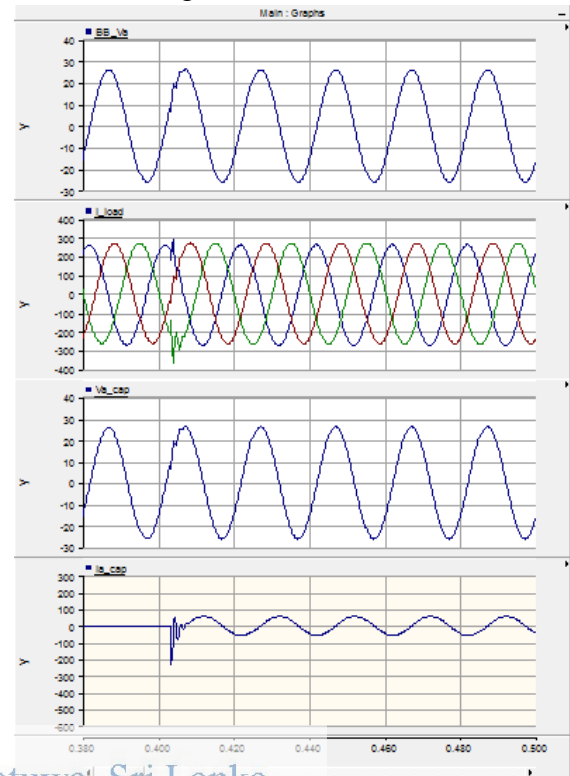

Zero Crossing+2ms

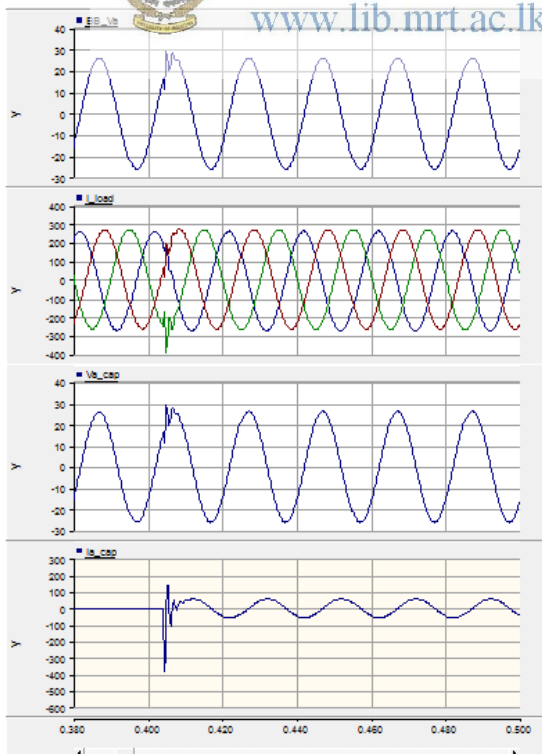

Zero Crossing+3ms

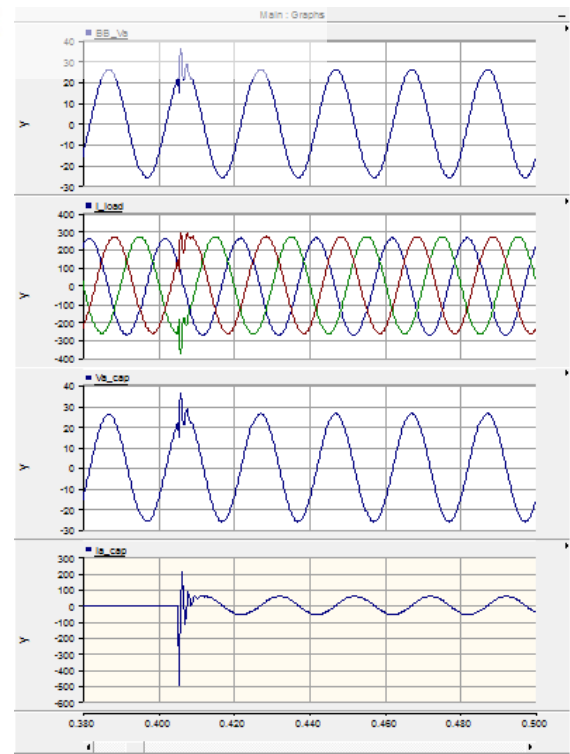

University of Moratuwa, Sri Lanka.

Electronic Theses & Dissertations

[www.lib.mrt.ac.lk](http://www.lib.mrt.ac.lk)

Zero Crossing+4ms

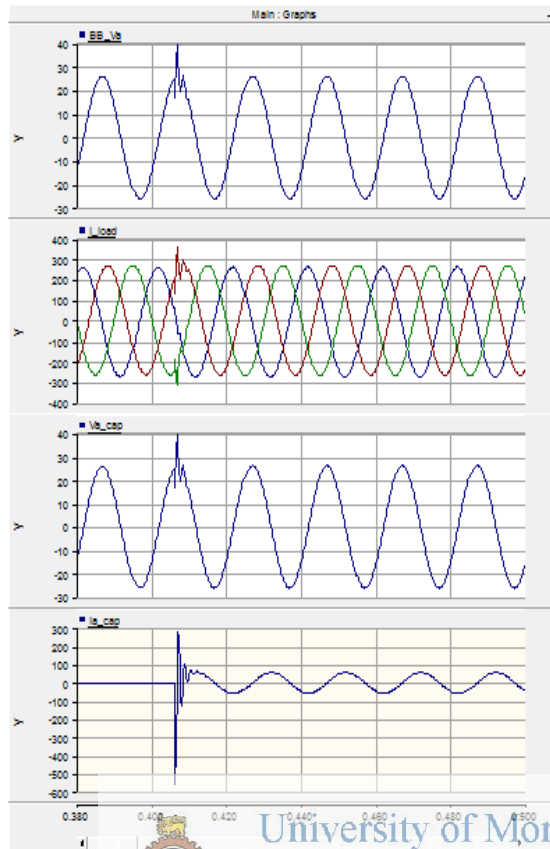

Zero Crossing+5ms

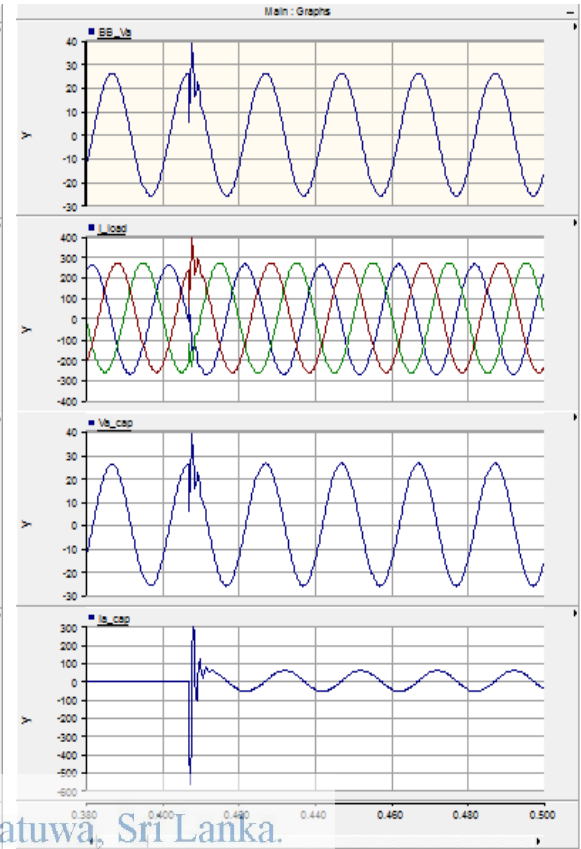

Zero Crossing+6ms

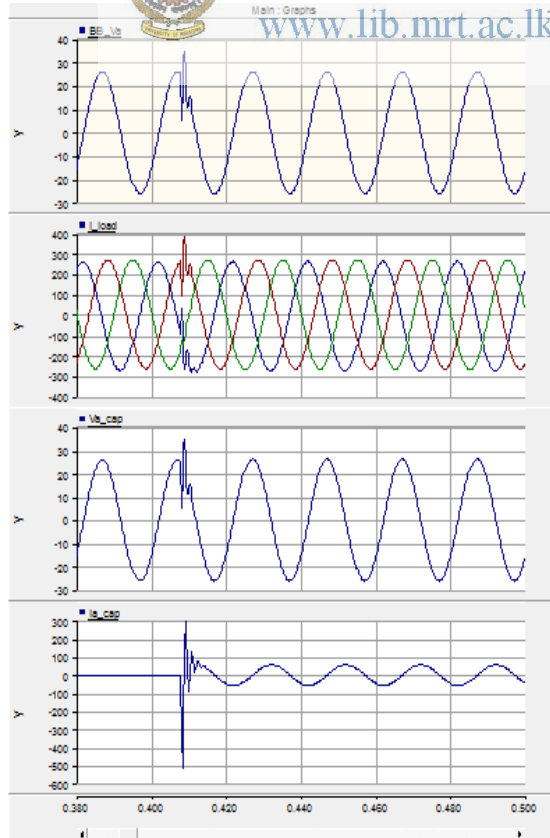

Zero Crossing+7ms

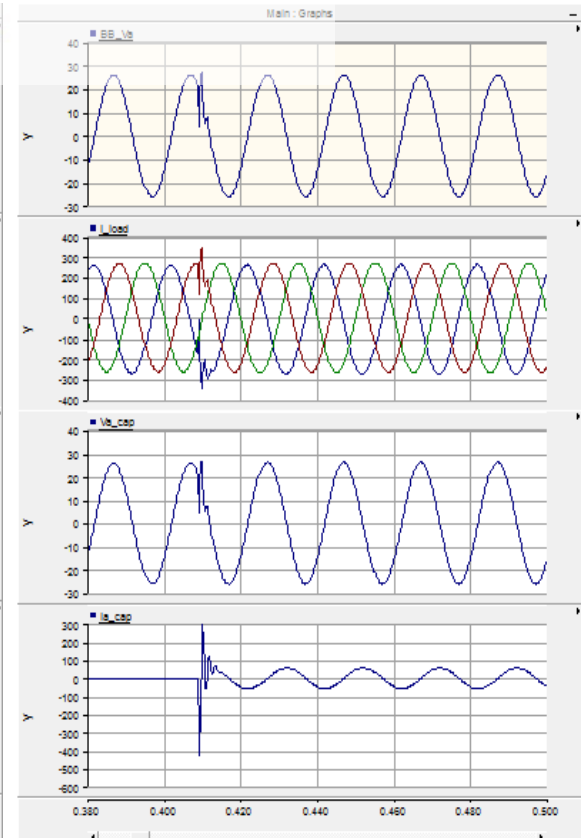

University of Moratuwa, Sri Lanka.  
Electronic Theses & Dissertations  
www.lib.mrt.ac.lk

Zero Crossing+8ms

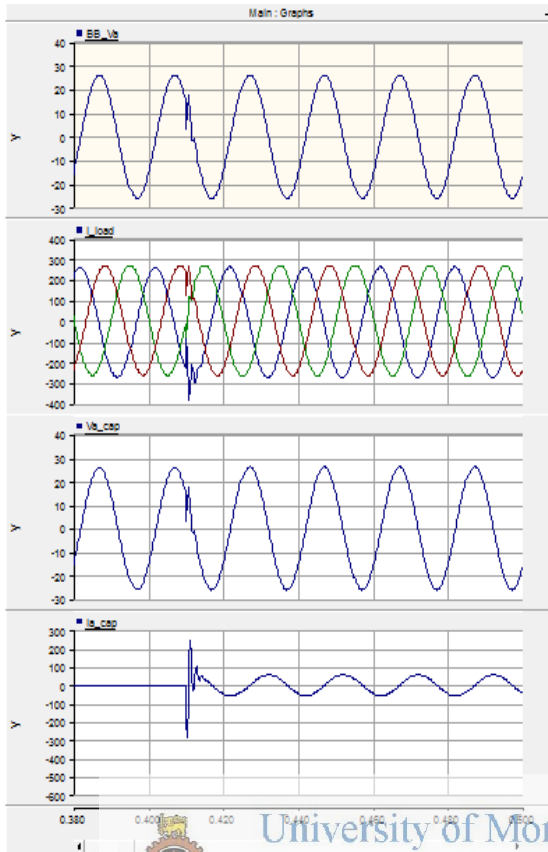

Zero Crossing+9ms

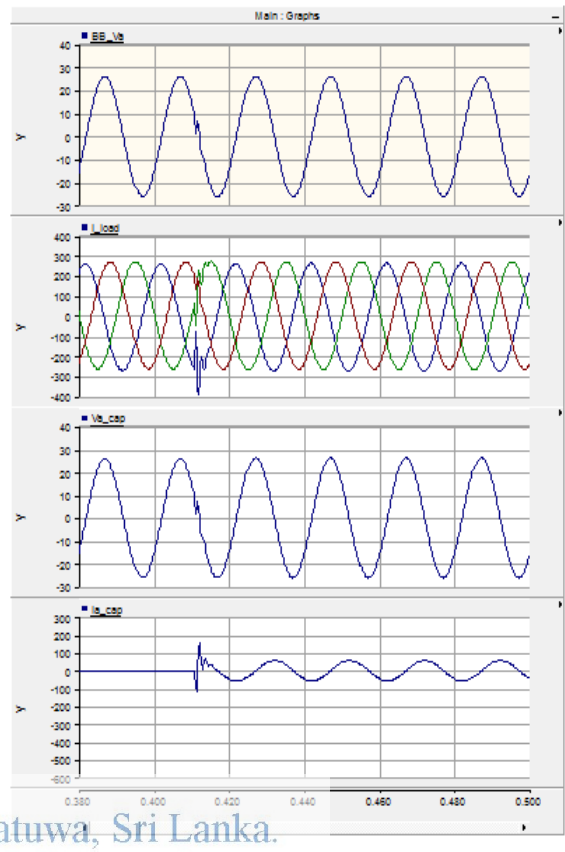

Zero Crossing+10ms

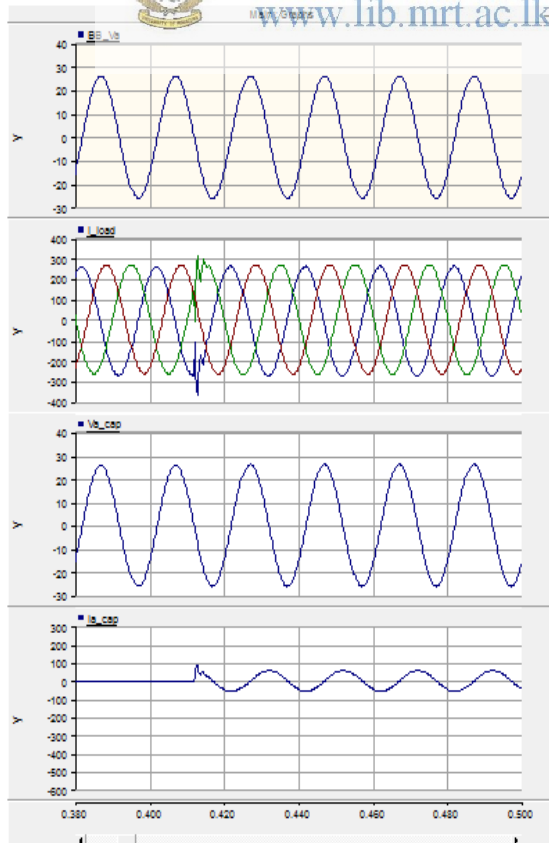

University of Moratuwa, Sri Lanka.

Electronic Theses & Dissertations

[www.lib.mrt.ac.lk](http://www.lib.mrt.ac.lk)

## Appendix 10 : Simulated waveforms for capacitor bank two closing

Zero Crossing

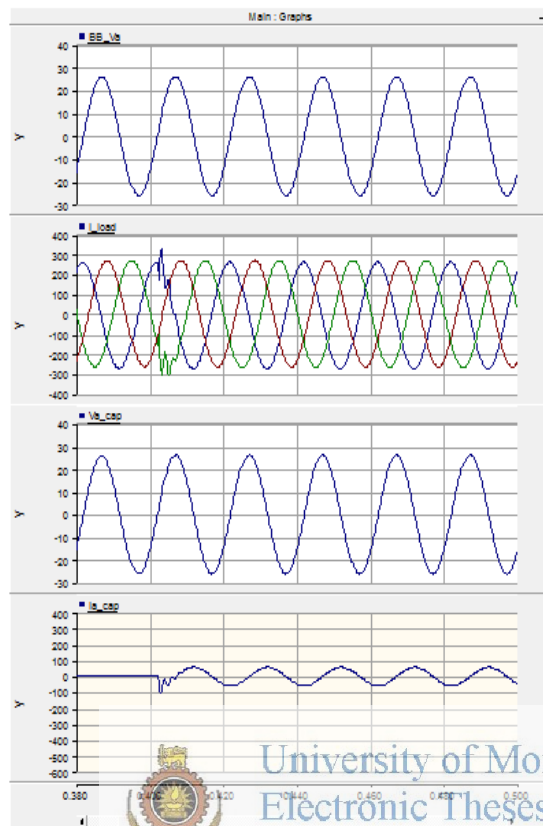

Zero Crossing+1ms

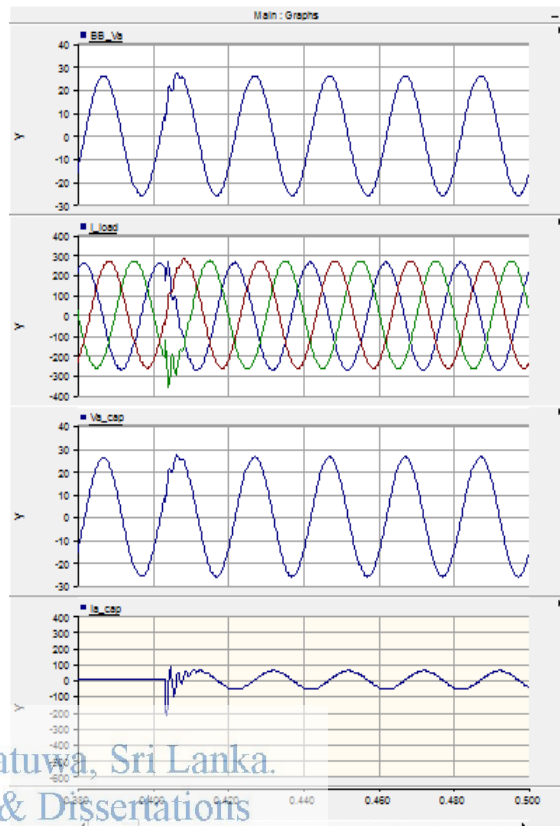

Zero Crossing+2ms

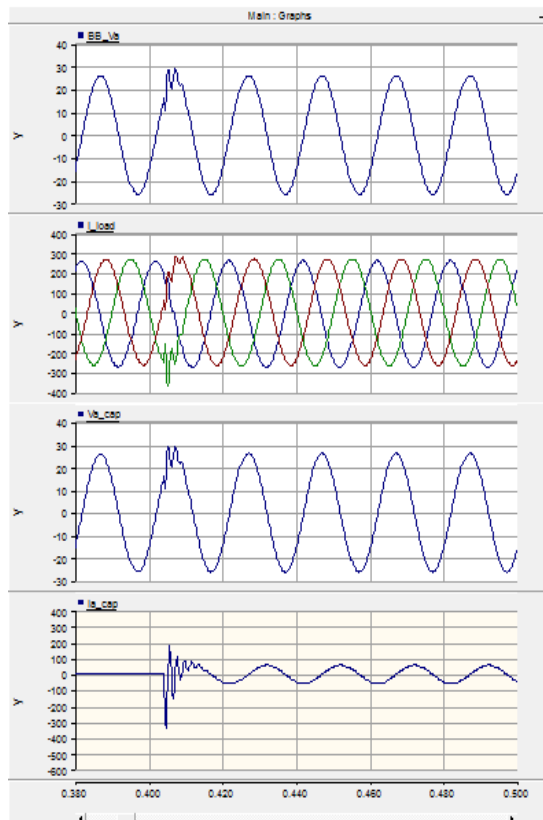

Zero Crossing+3ms

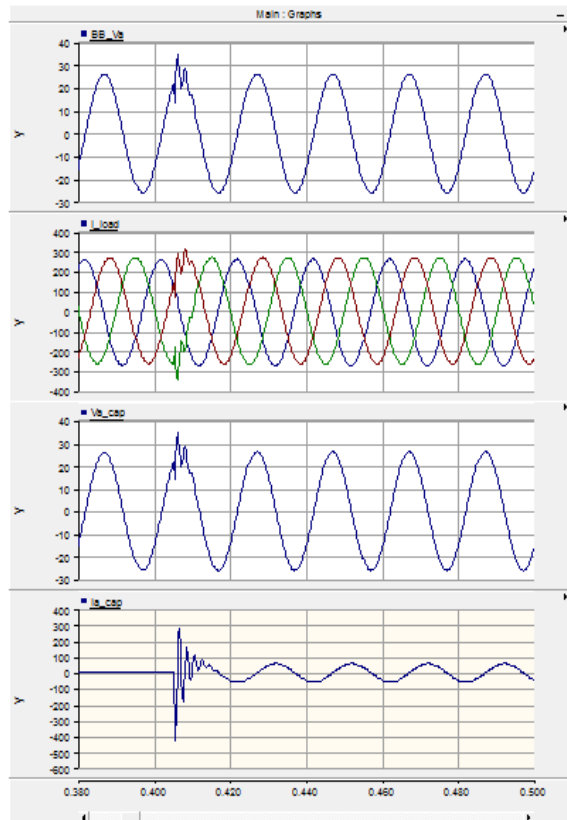



Zero Crossing+4ms

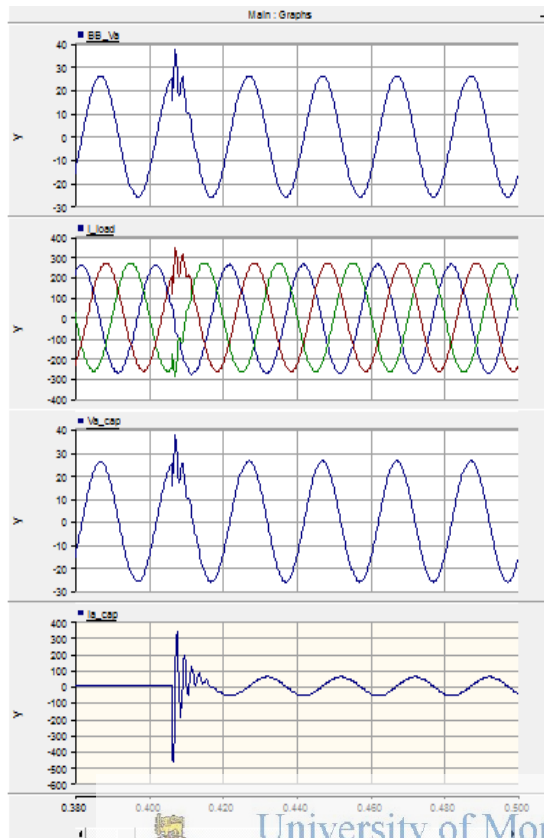

Zero Crossing+5ms

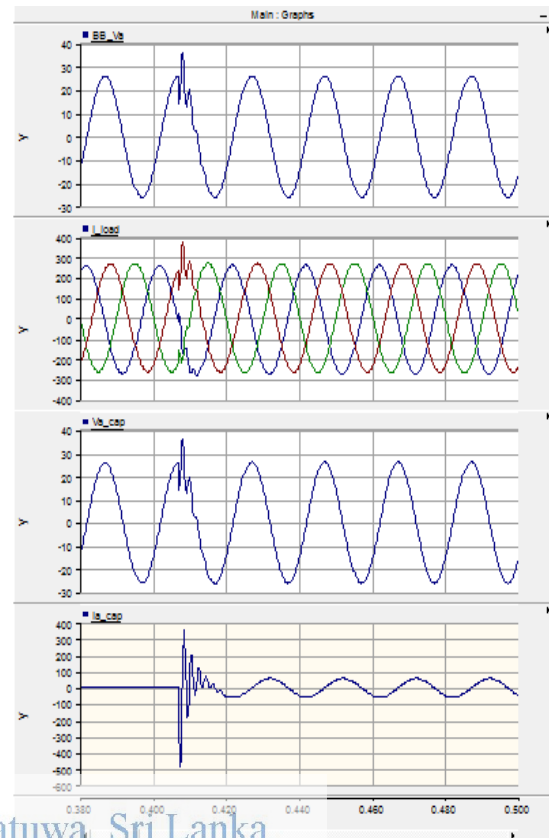

Zero Crossing+6ms

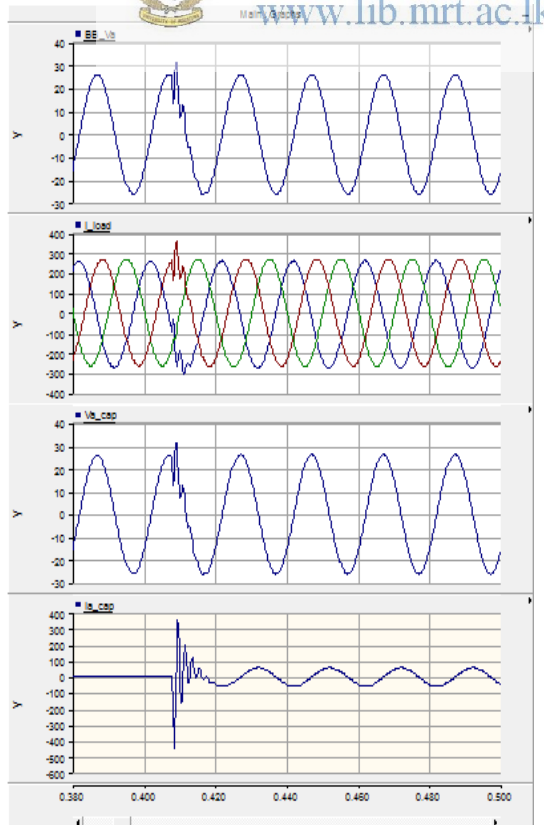

University of Moratuwa, Sri Lanka.  
Electronic Theses & Dissertations  
www.lib.mrt.ac.lk

Zero Crossing+7ms

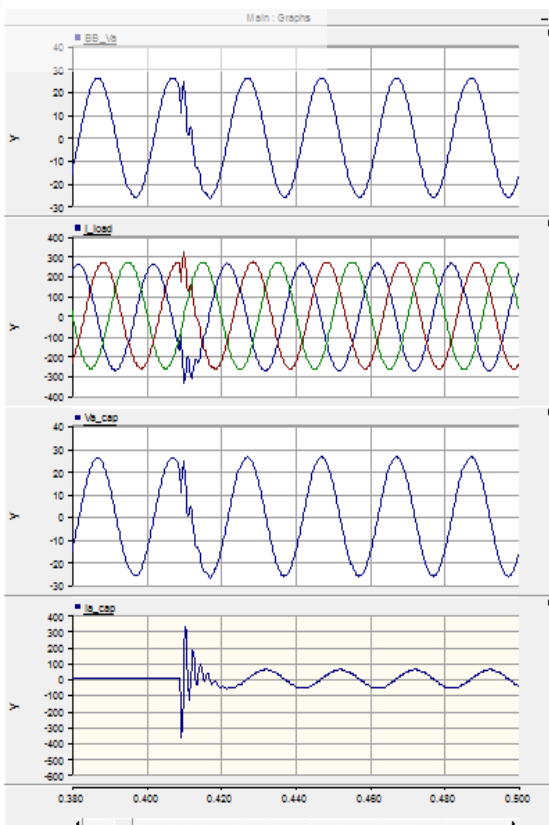

Zero Crossing+8ms

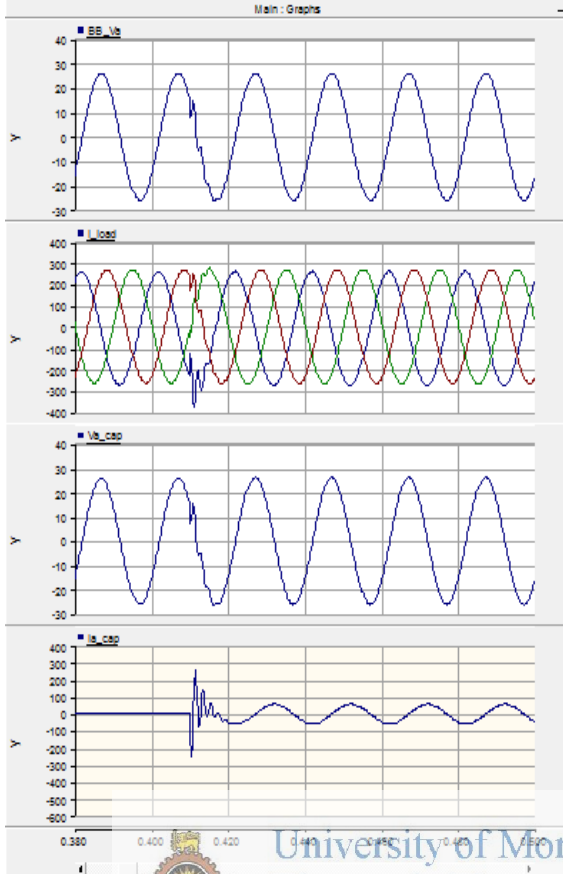

Zero Crossing+9ms

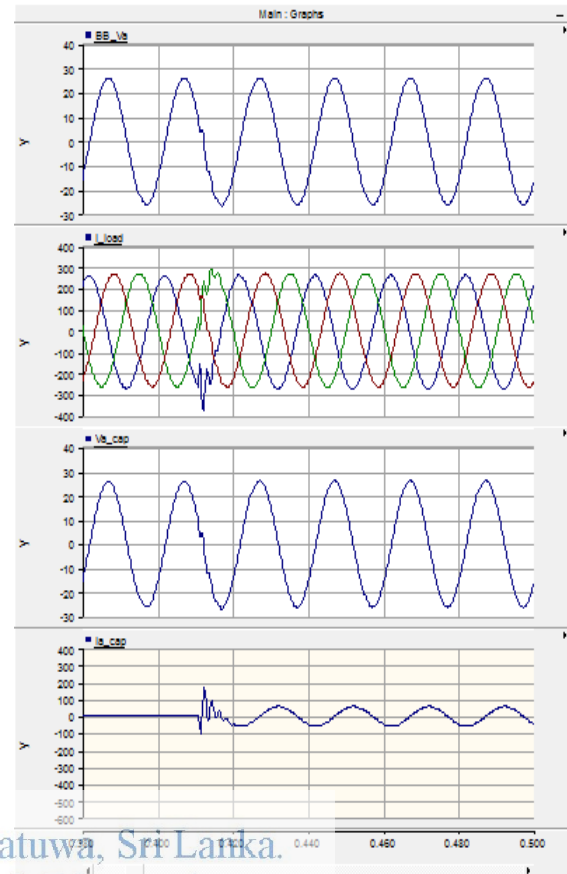

Zero Crossing+10ms

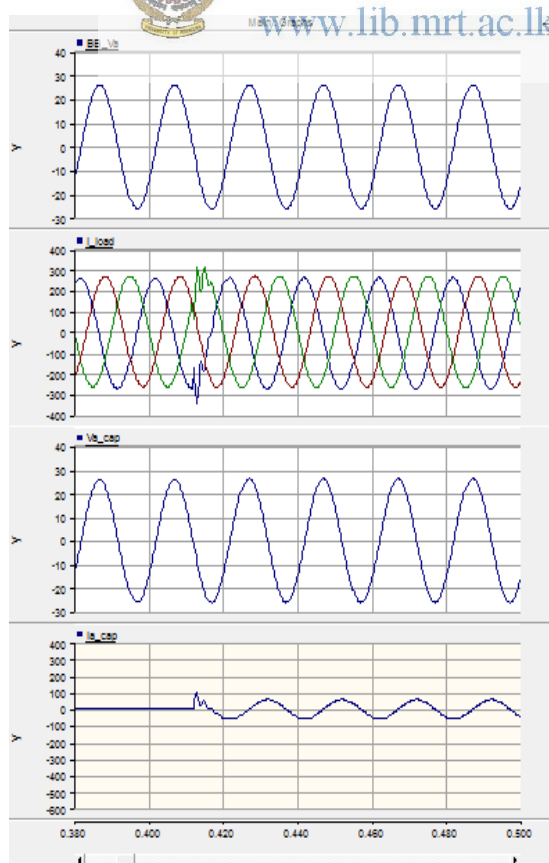

University of Moratuwa, Sri Lanka.  
Electronic Theses & Dissertations  
[www.lib.mrt.ac.lk](http://www.lib.mrt.ac.lk)

## Appendix 11: Switching of capacitor bank one for randomly selected loads at voltage peak

00.30 hr

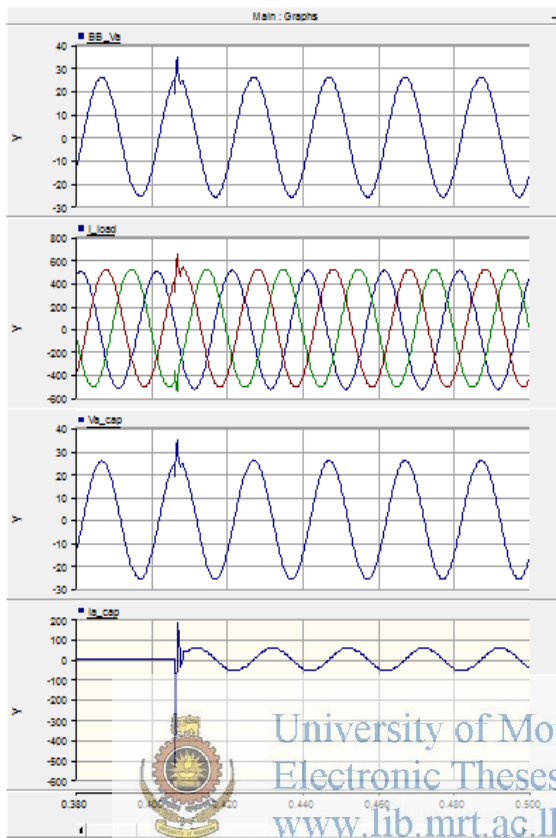

04.00 hr

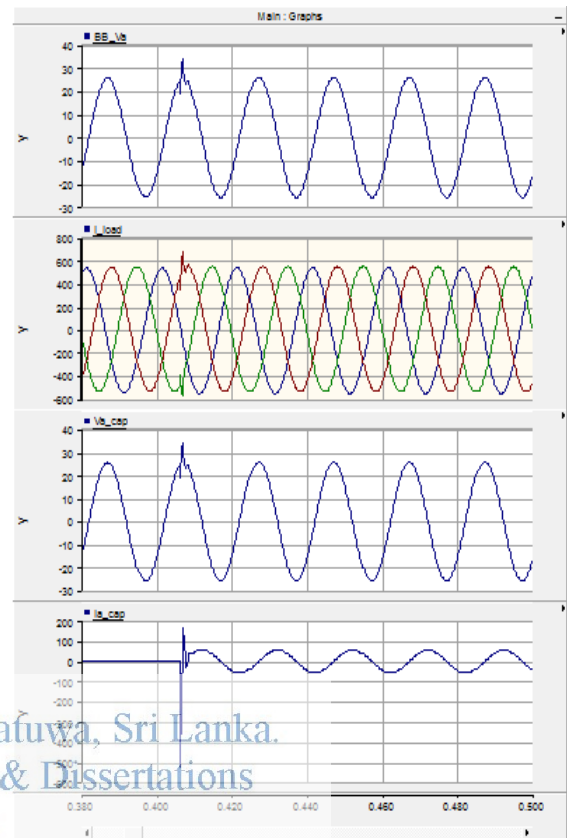

06.00 hr

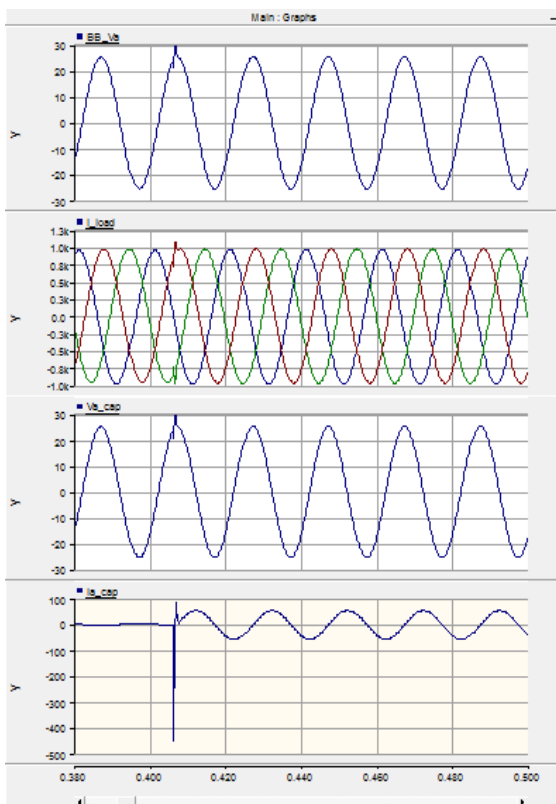

09.00 hr

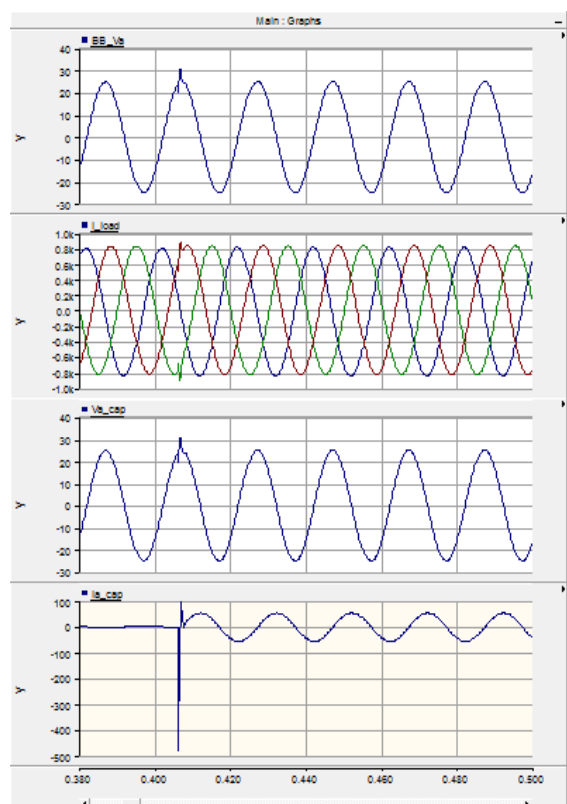

12.00 hr

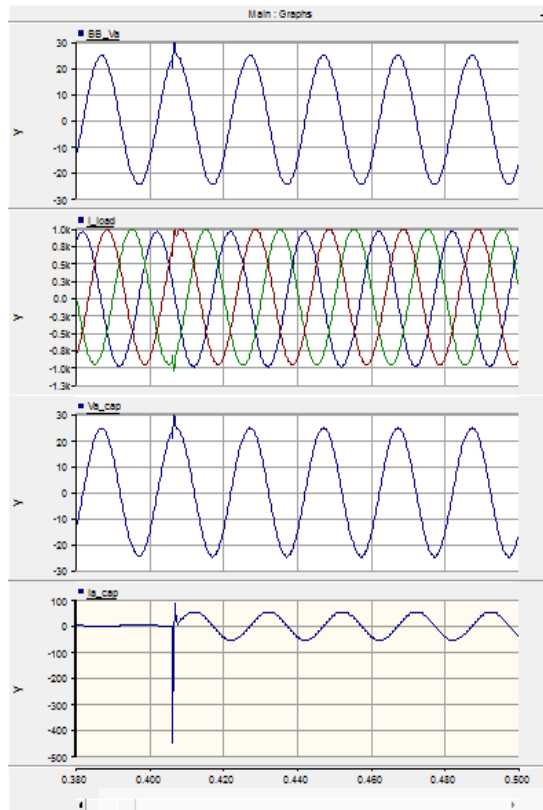

15.00 hr

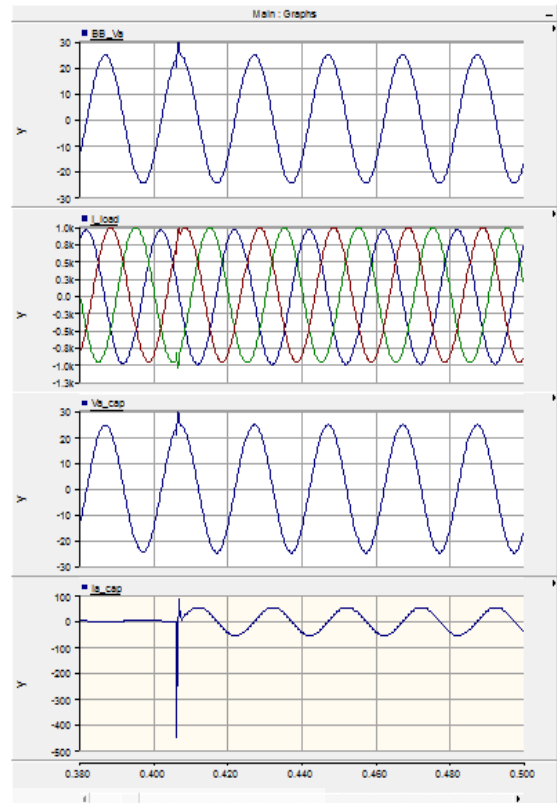

17.00 hr



University of Moratuwa, Sri Lanka.

Electronic Theses & Dissertations

[www.lib.mrt.ac.lk](http://www.lib.mrt.ac.lk)

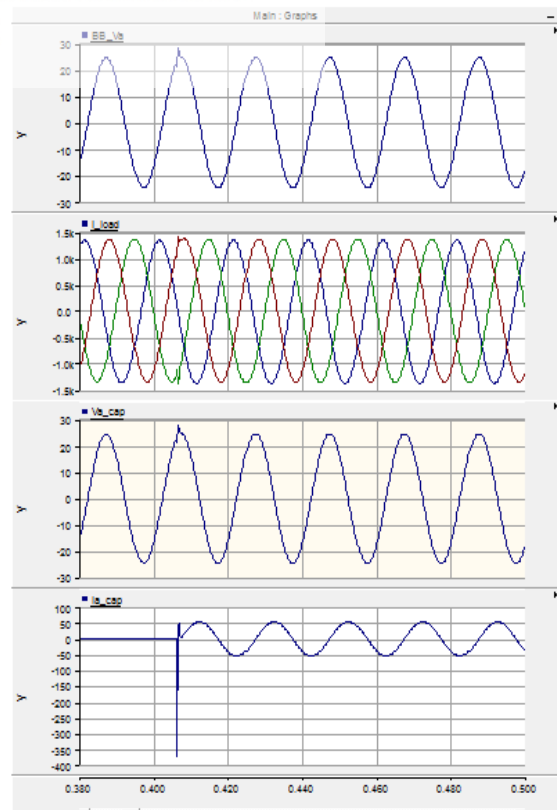
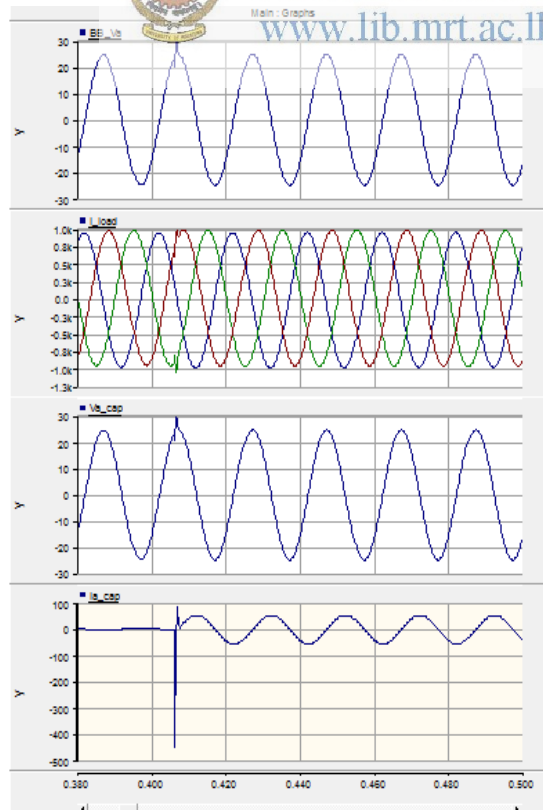

21.30 hr

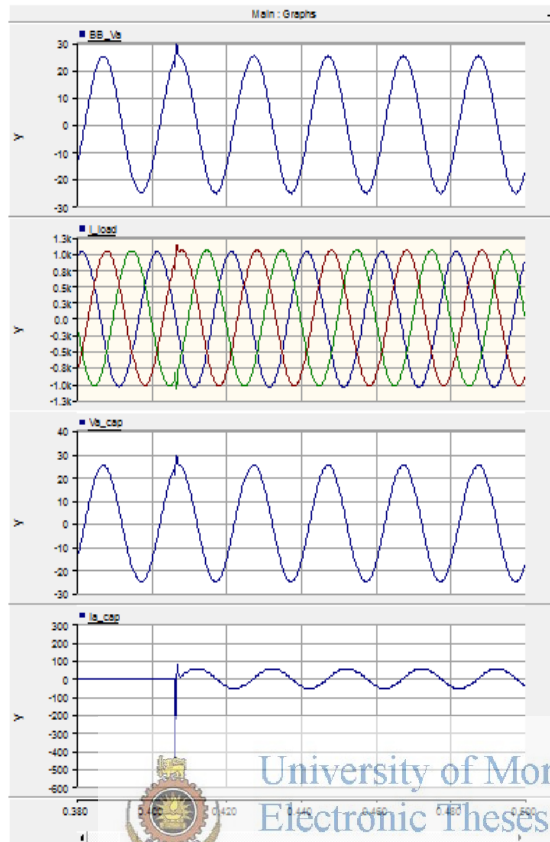

23.00 hr

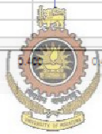
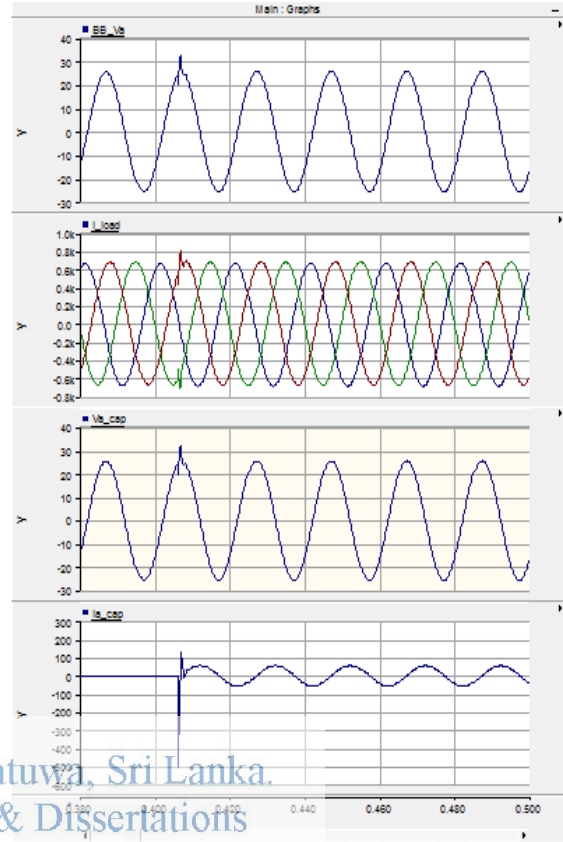

University of Moratuwa, Sri Lanka.  
Electronic Theses & Dissertations  
[www.lib.mrt.ac.lk](http://www.lib.mrt.ac.lk)

## Appendix 12: Switching of capacitor bank two for randomly selected loads at voltage peak

00.30 hr

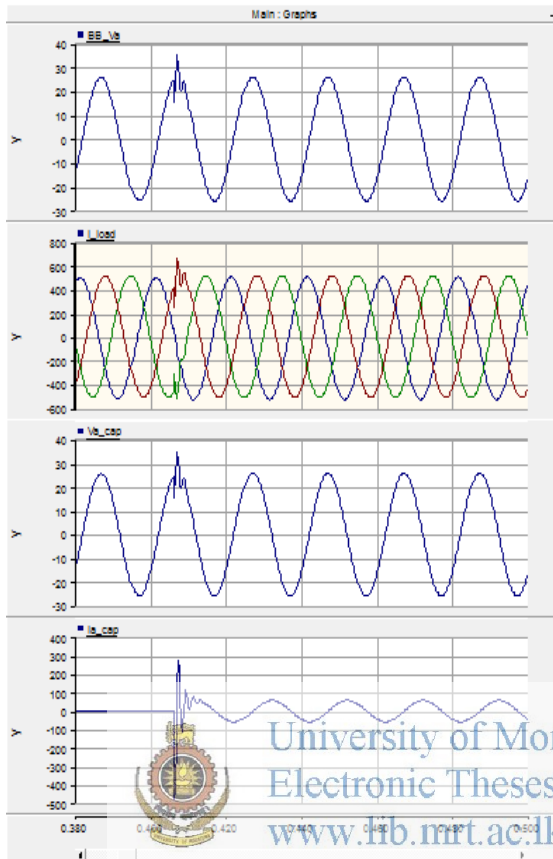

04.00 hr

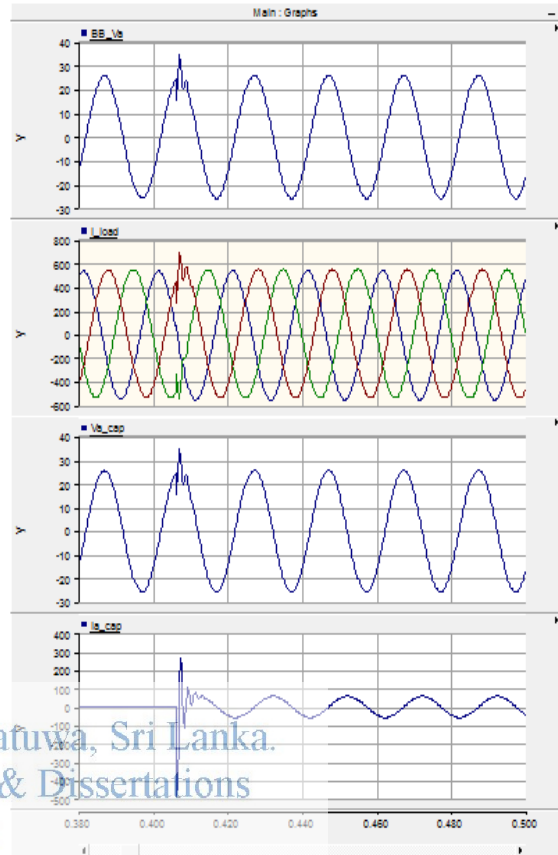

06.00 hr

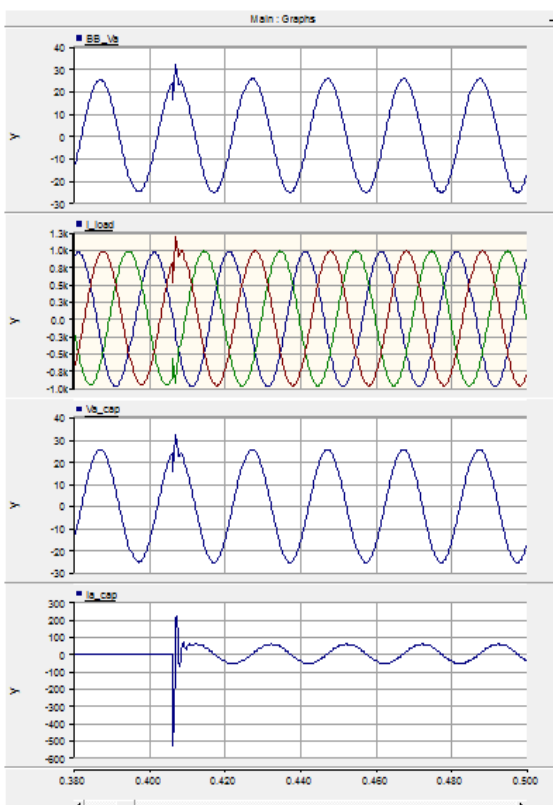

09.00 hr

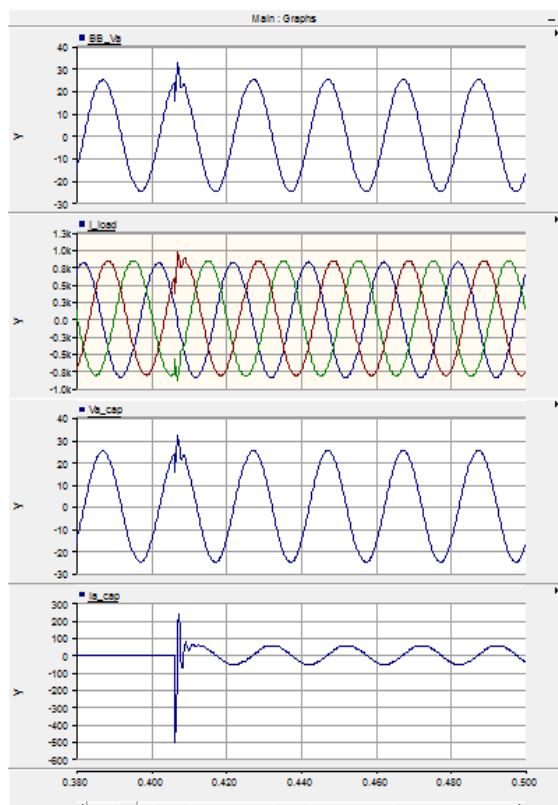

12.00 hr

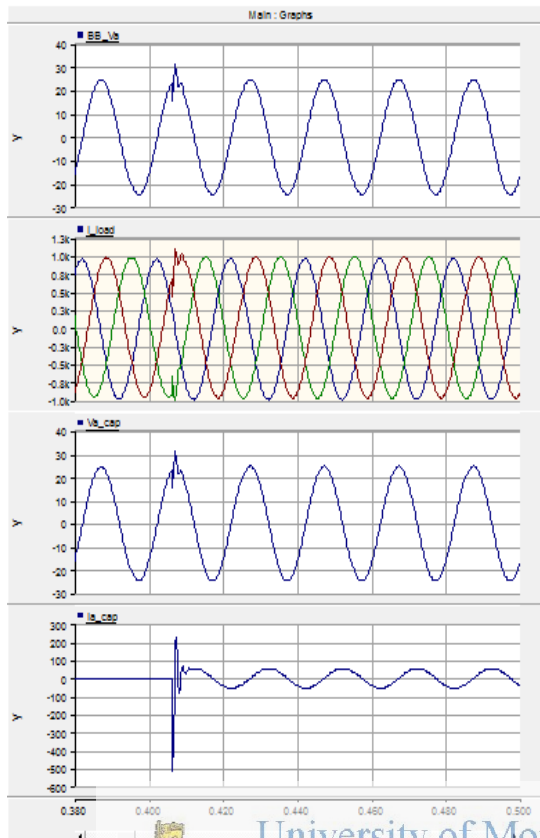

15.00 hr

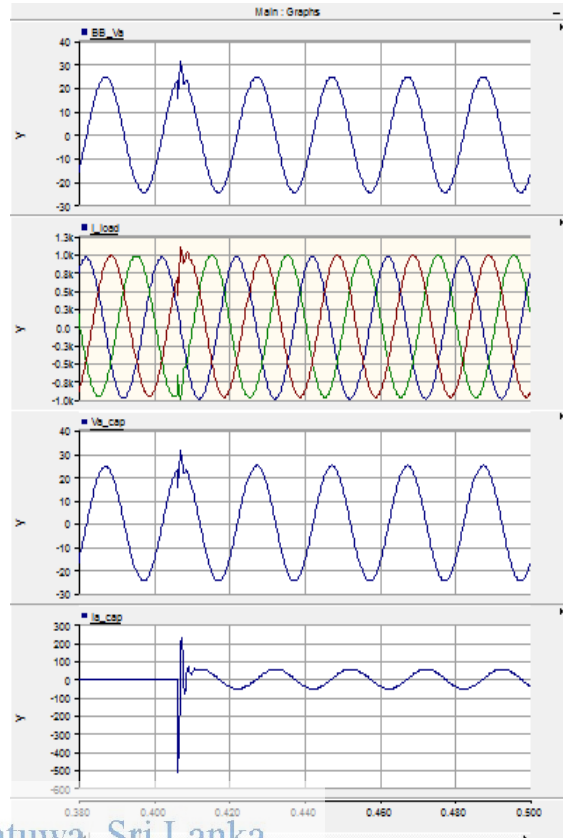

17.00 hr

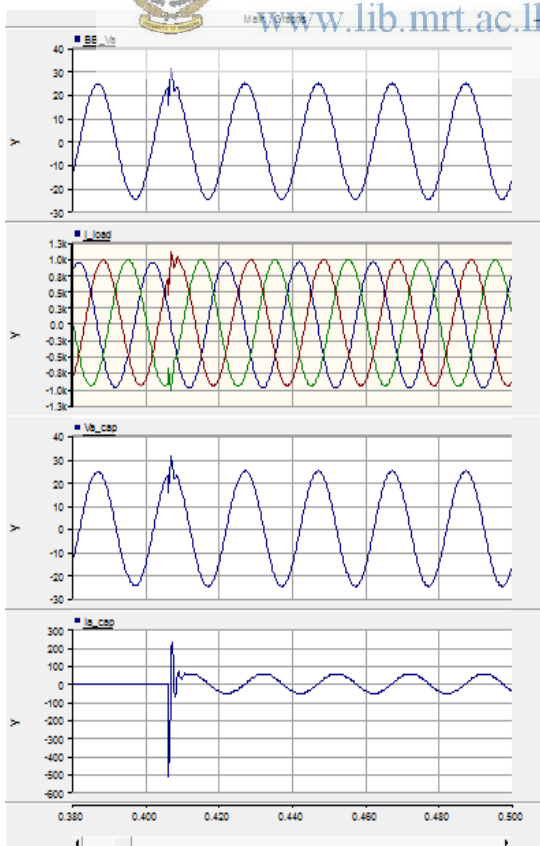

19.30 hr

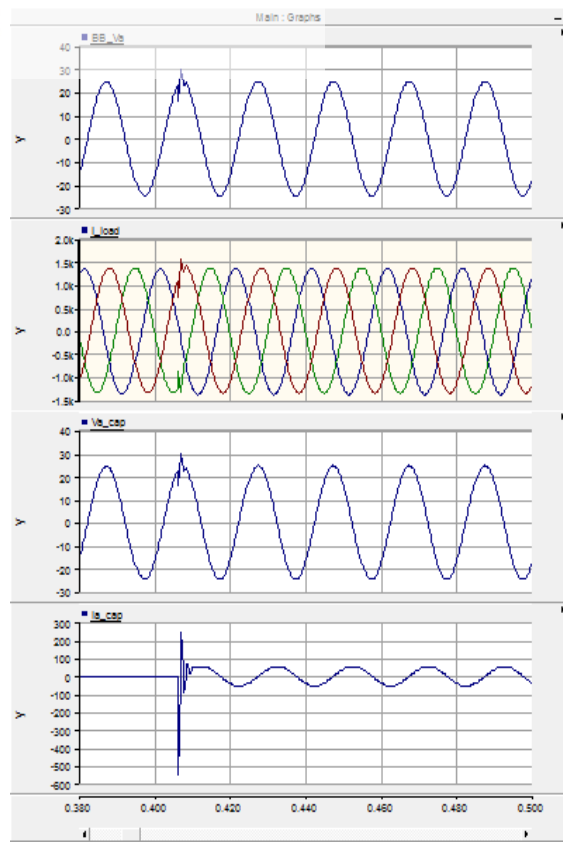

University of Moratuwa, Sri Lanka.  
Electronic Theses & Dissertations  
[www.lib.mrt.ac.lk](http://www.lib.mrt.ac.lk)

21.30 hr

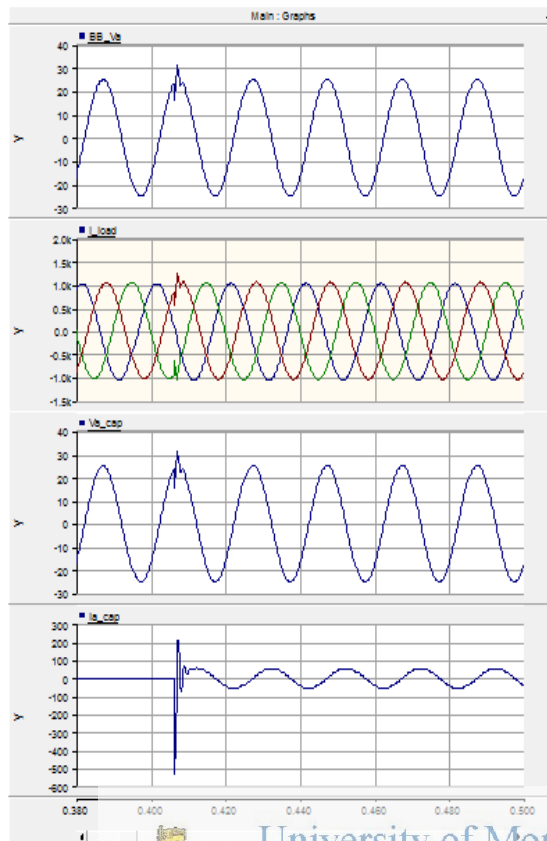

23.00 hr

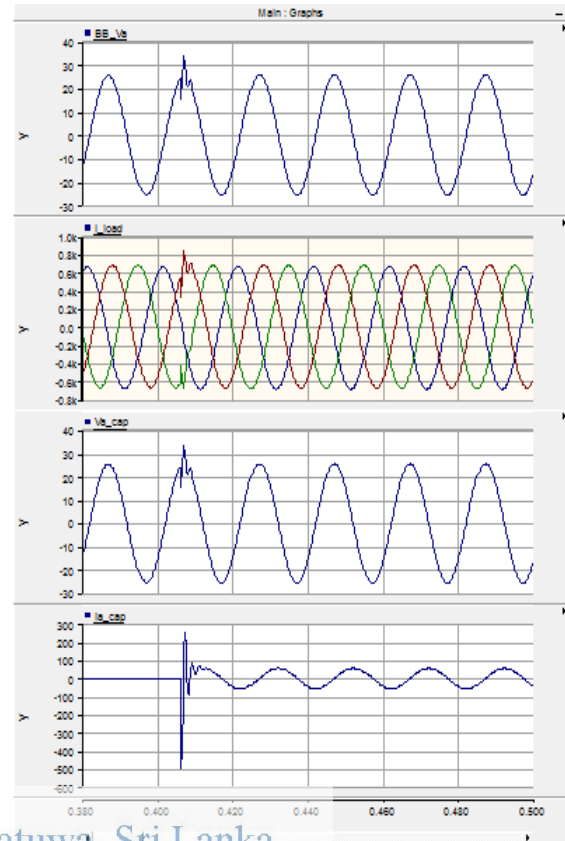

University of Moratuwa, Sri Lanka.  
Electronic Theses & Dissertations  
[www.lib.mrt.ac.lk](http://www.lib.mrt.ac.lk)



### Appendix 13: Fast switching of capacitor banks sequence of bank one to two with 1 ms delay time increasing

4 ms delay

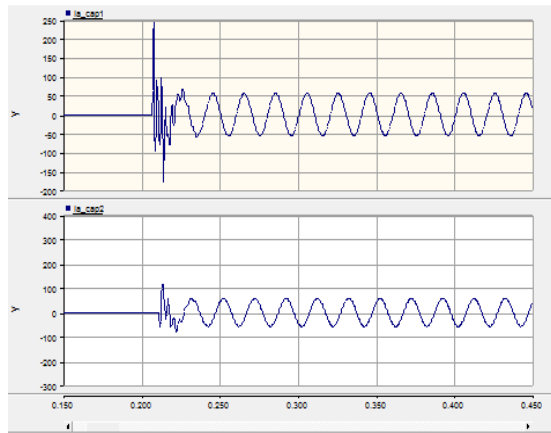

5 ms delay

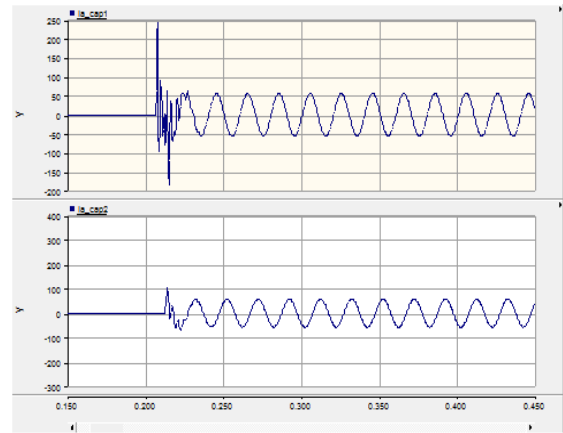

6ms delay

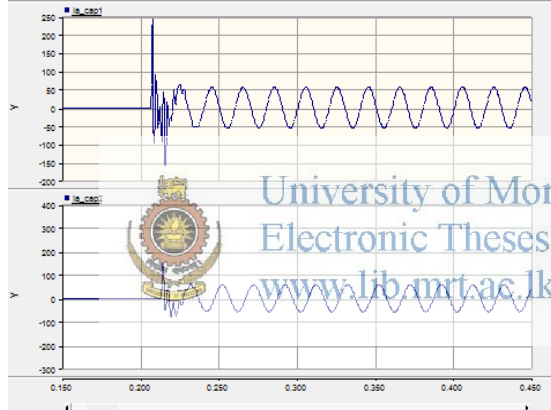

7 ms delay

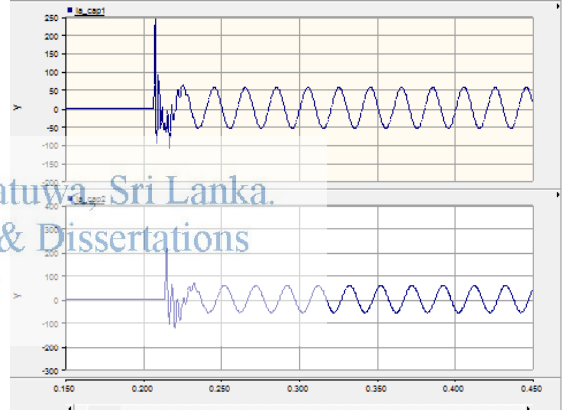

8ms delay

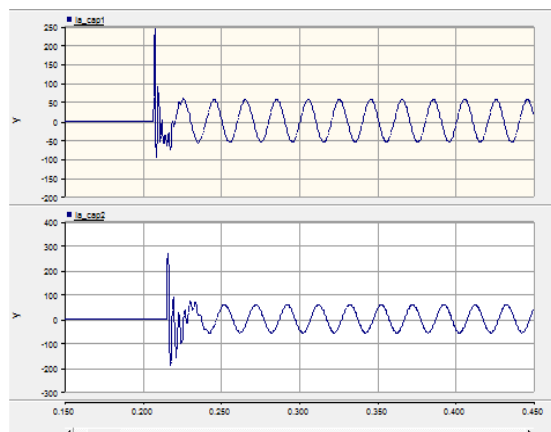

9 ms delay

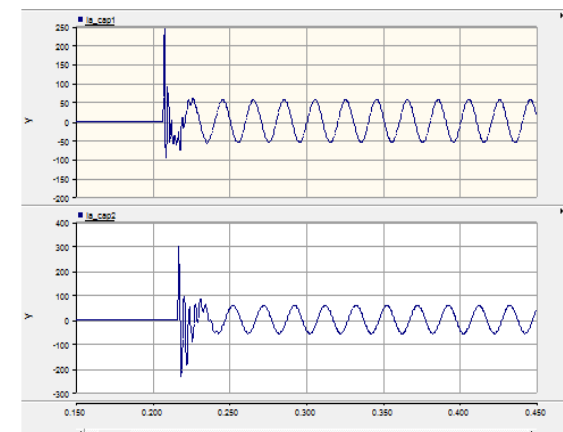

University of Moratuwa, Sri Lanka.  
Electronic Theses & Dissertations  
[www.lib.mrt.ac.lk](http://www.lib.mrt.ac.lk)

10ms delay

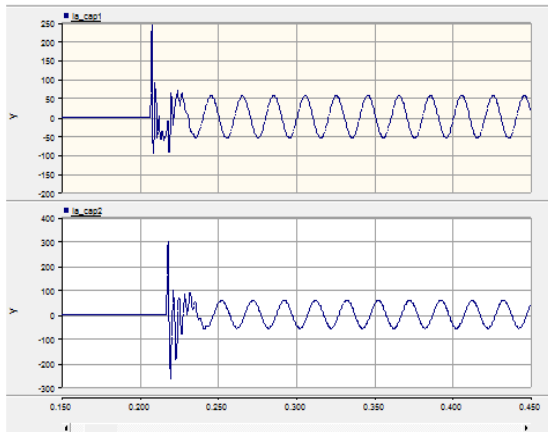

11 ms delay

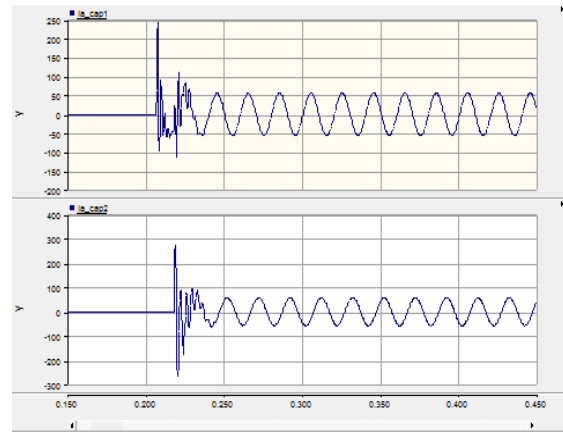

12ms delay

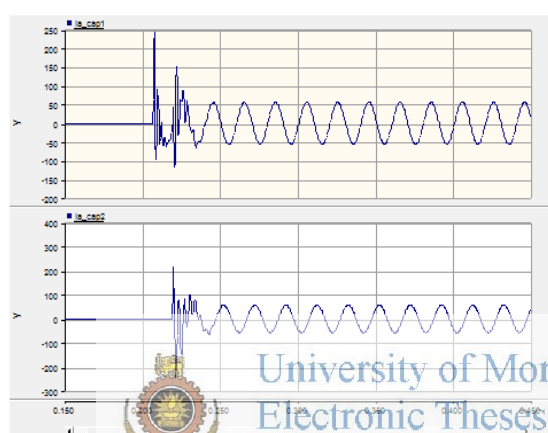

13 ms delay

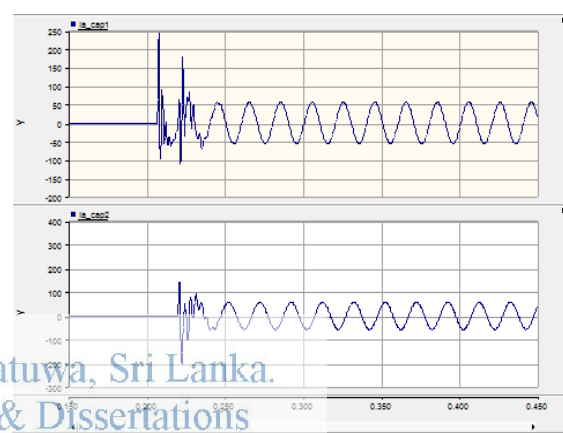

14ms delay

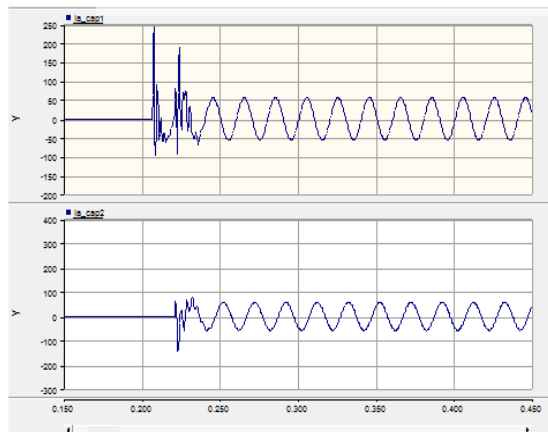

15 ms delay

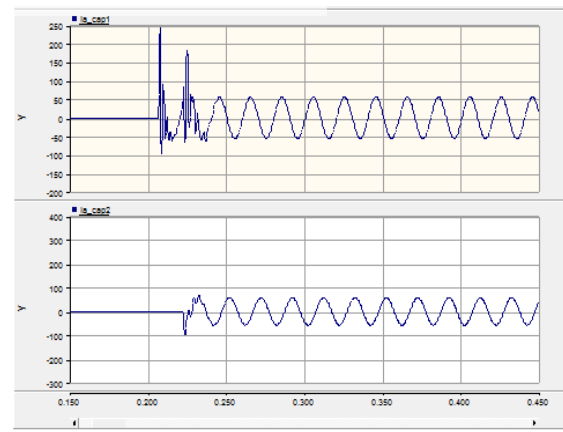

16ms delay

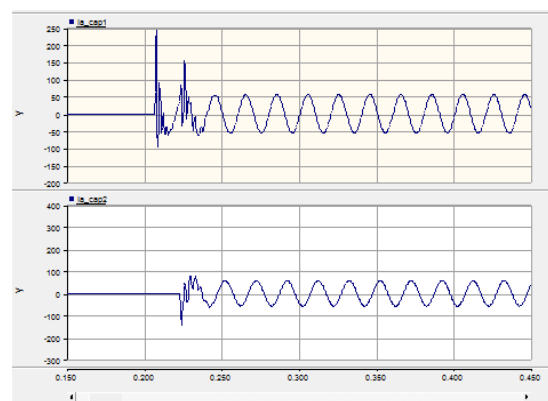

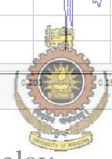
 University of Moratuwa, Sri Lanka.  
Electronic Theses & Dissertations  
[www.lib.mrt.ac.lk](http://www.lib.mrt.ac.lk)

## Appendix 14: Fast switching of capacitor banks sequence of bank two to one with 1 ms delay time increasing

20 ms delay

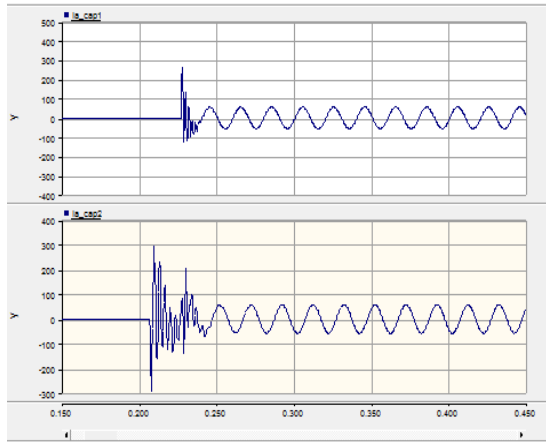

21 ms delay

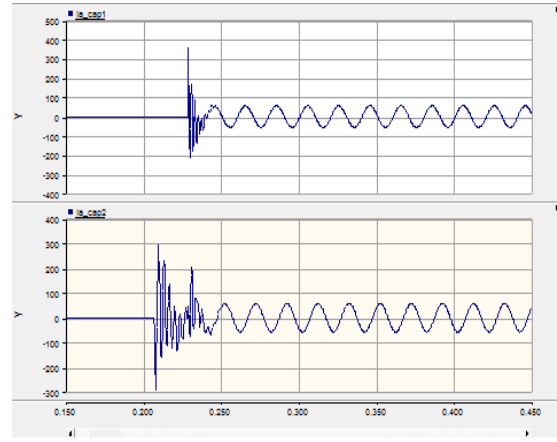

22 ms delay

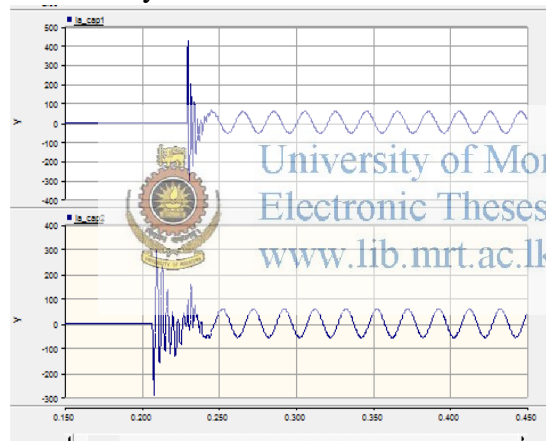

23 ms delay

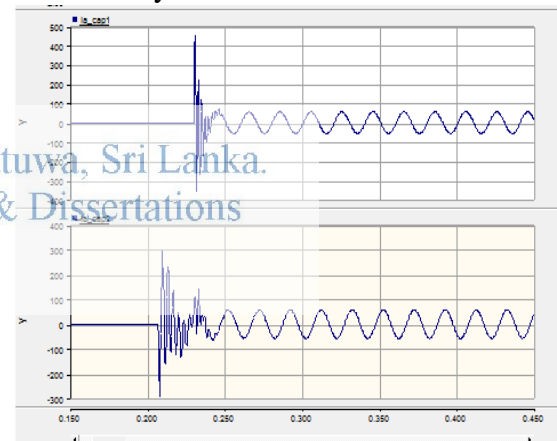

24 ms delay

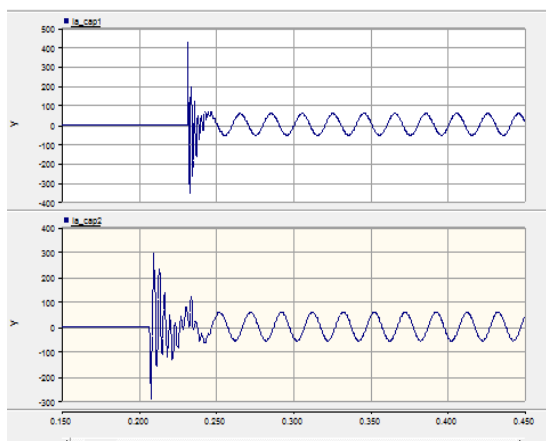

25 ms delay

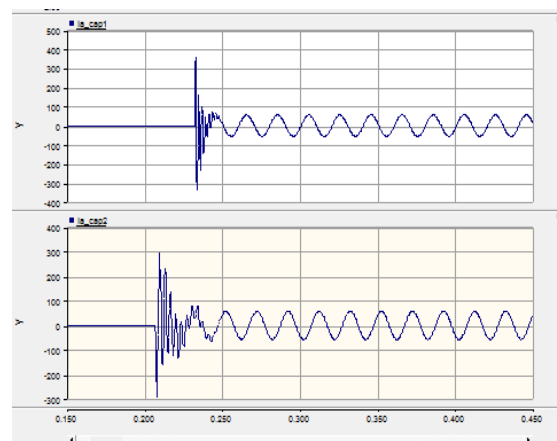

26 ms delay

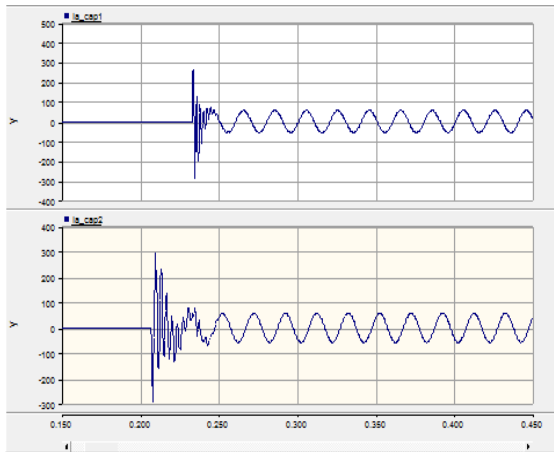

27 ms delay

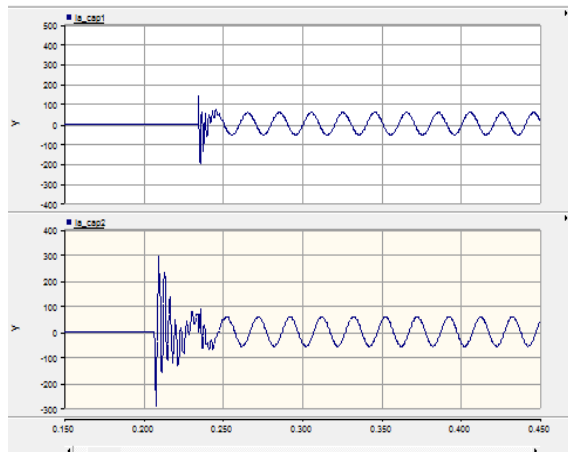

28 ms delay

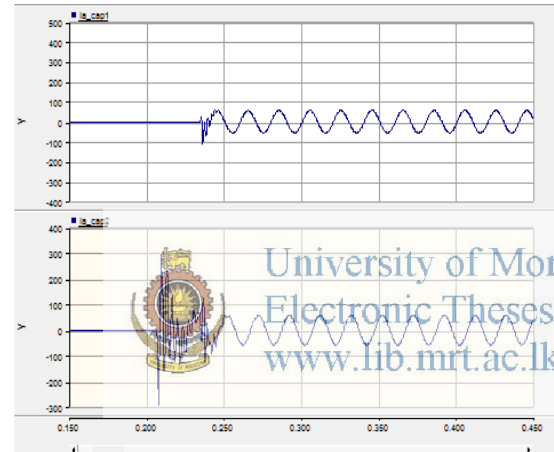

29 ms delay

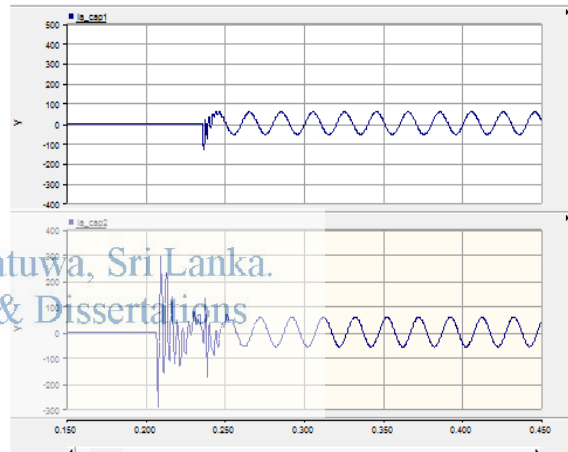

University of Moratuwa, Sri Lanka.  
Electronic Theses & Dissertations  
[www.lib.mrt.ac.lk](http://www.lib.mrt.ac.lk)

## Appendix 15: Fast switching for selected loading

Fast switching for several 33 kV loading (00.30 hr)

Switching sequence bank one to two

Switching sequence two to one

7ms delay

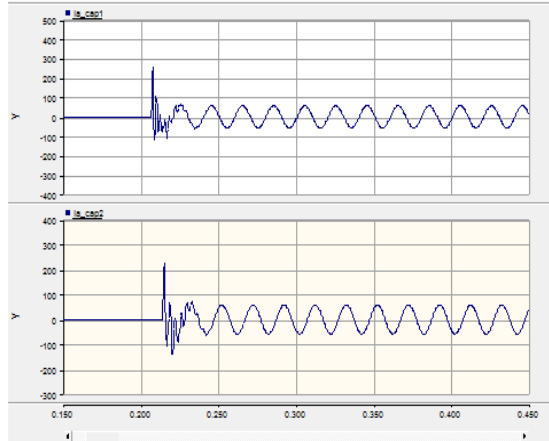

13 ms delay

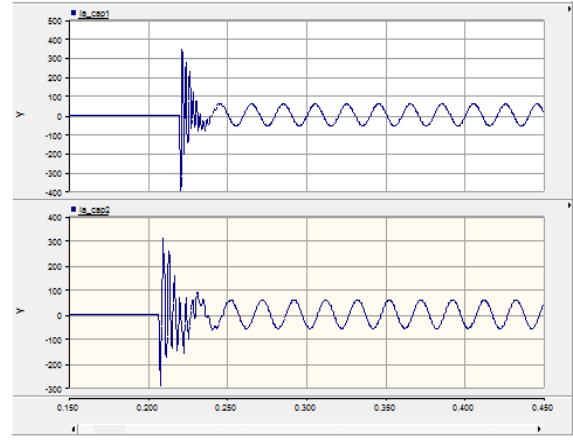

13 ms delay

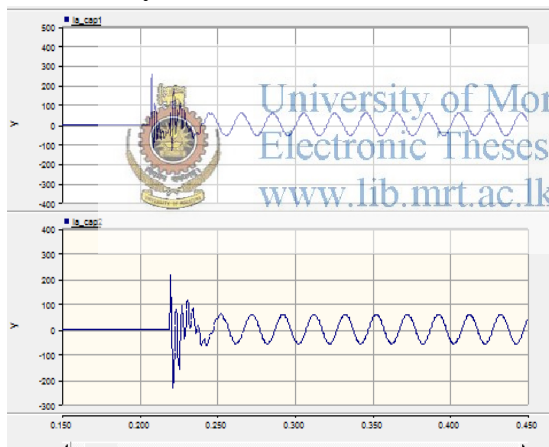

30 ms delay

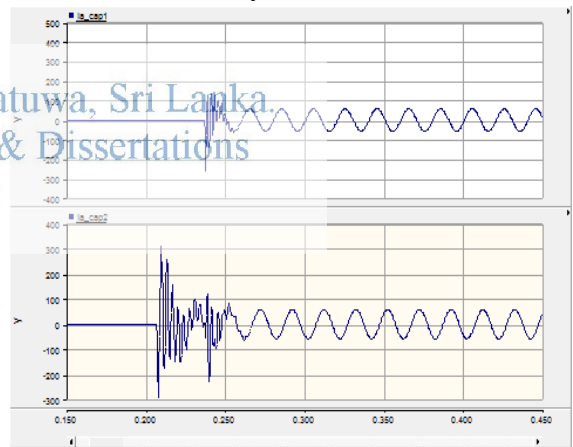

18 ms delay

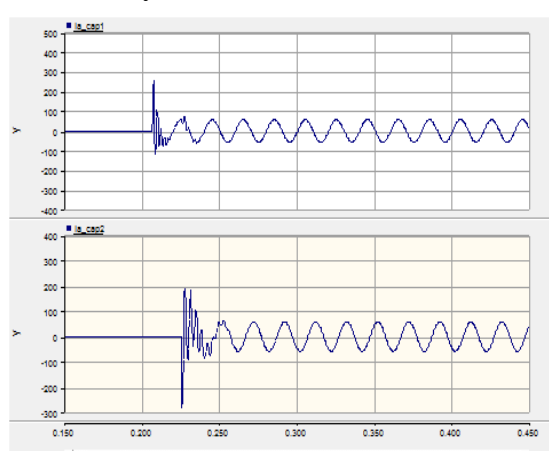

38 ms delay

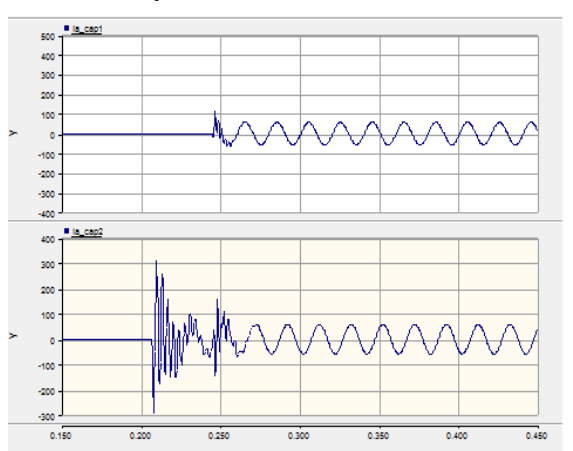

Fast switching for several 33 kV loading (04.00 hr)

Switching sequence bank one to two

Switching sequence two to one

3ms delay

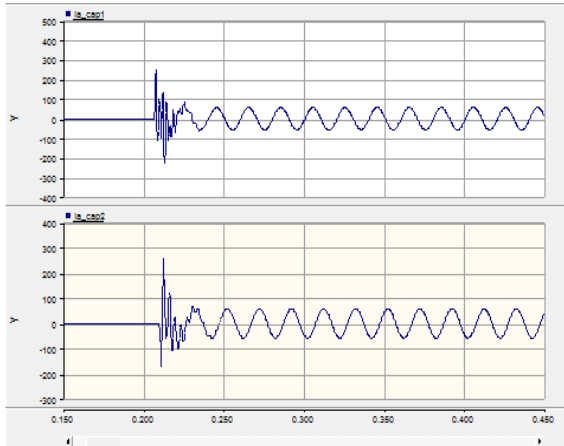

13 ms delay

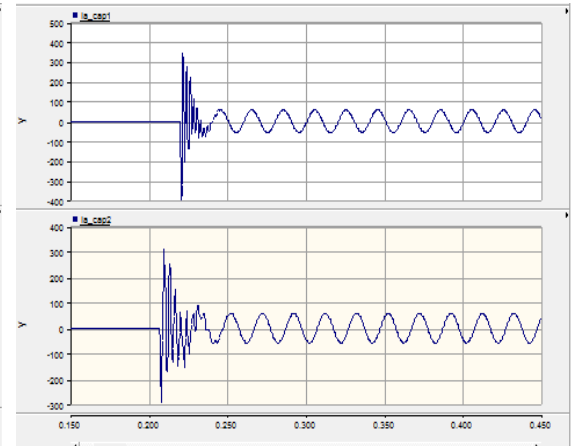

11 ms delay

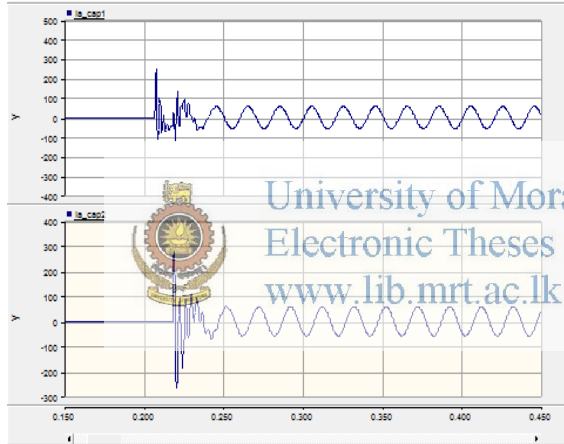

29 ms delay

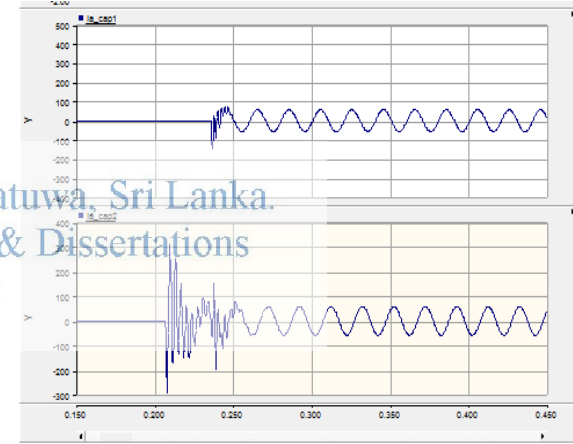

18 ms delay

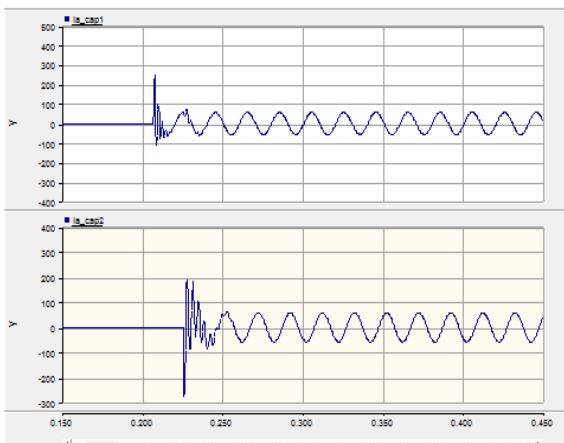

38 ms delay

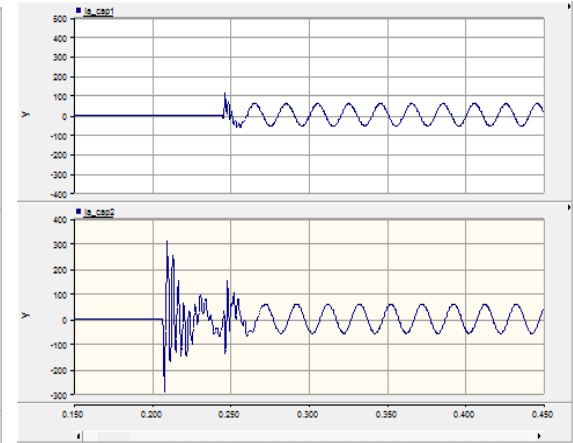

University of Moratuwa, Sri Lanka.  
Electronic Theses & Dissertations  
[www.lib.mrt.ac.lk](http://www.lib.mrt.ac.lk)

Fast switching for several 33 kV loading (06.00 hr)

Switching sequence bank one to two

Switching sequence two to one

3 ms delay

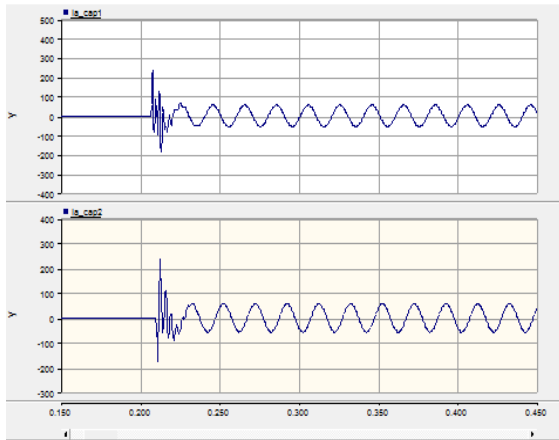

3 ms delay

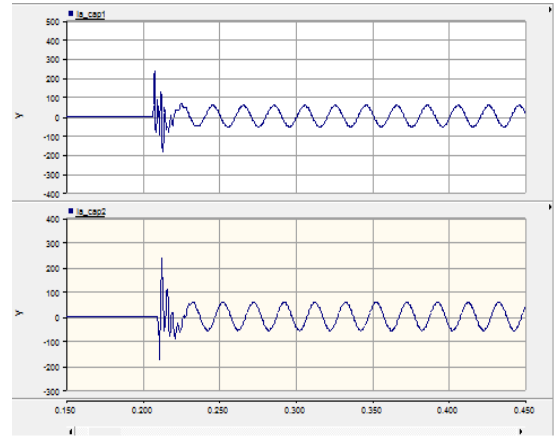

13 ms delay

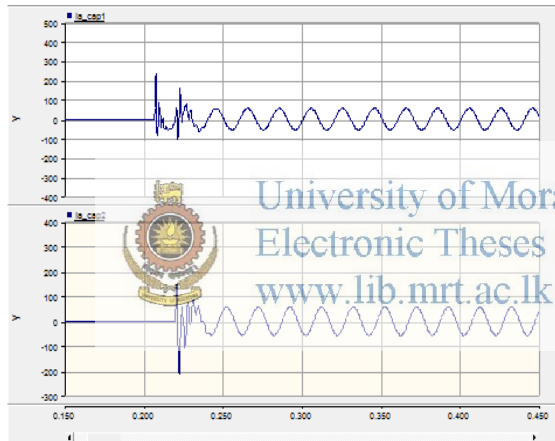

30 ms delay

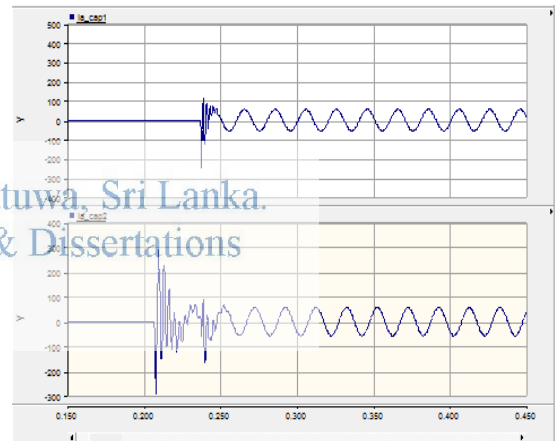

18 ms delay

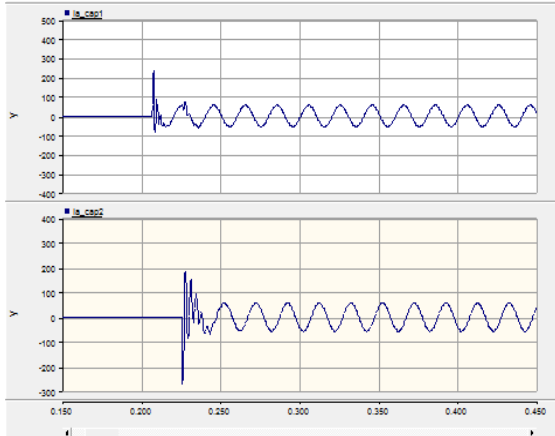

48 ms delay

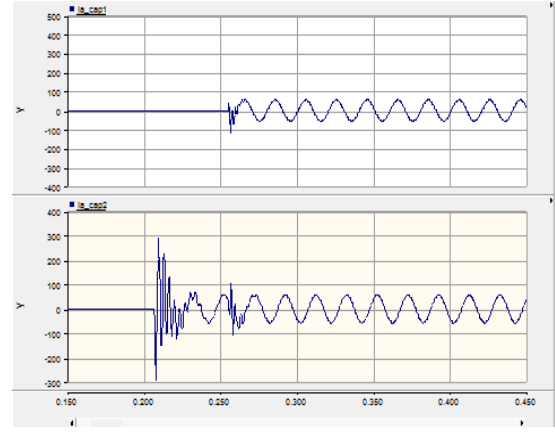

Fast switching for several 33 kV loading (09.00 hr)

Switching sequence bank one to two

Switching sequence two to one

3 ms delay

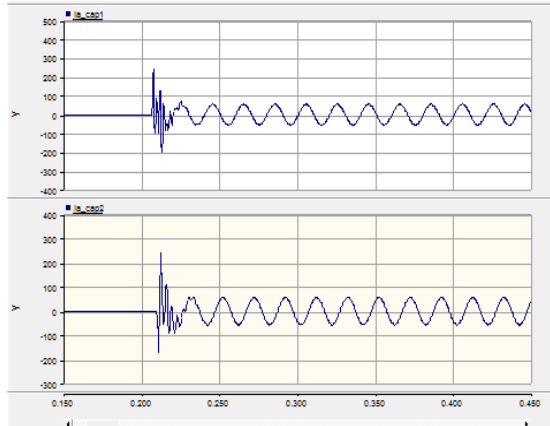

3 ms delay

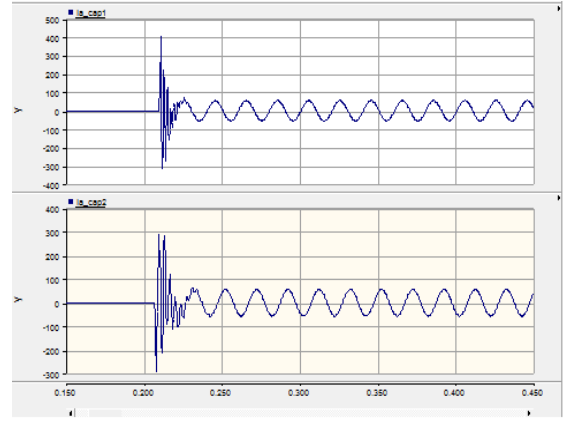

10 ms delay

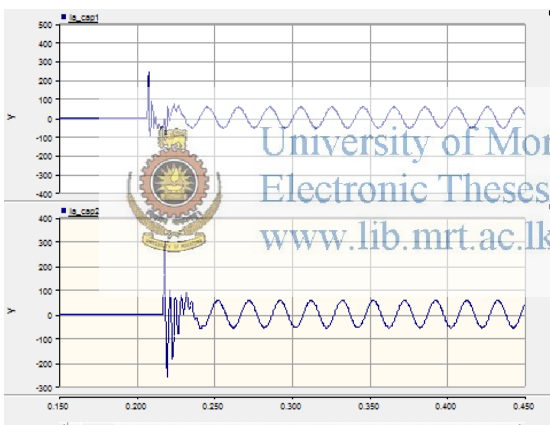

28 ms delay

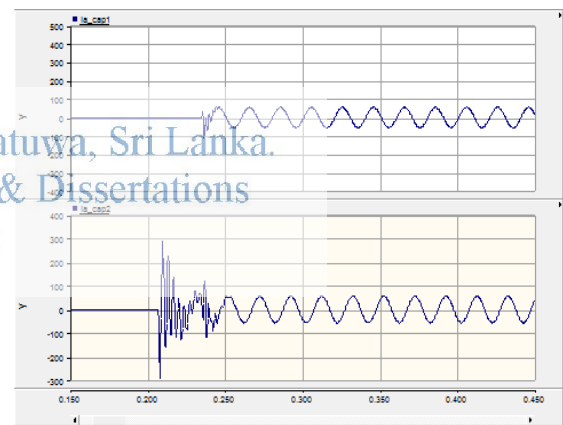

18 ms delay

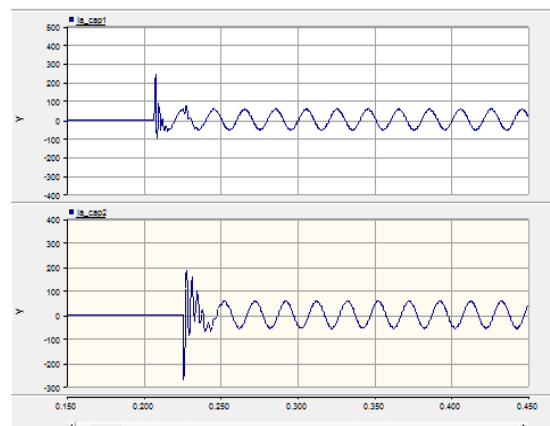

38 ms delay

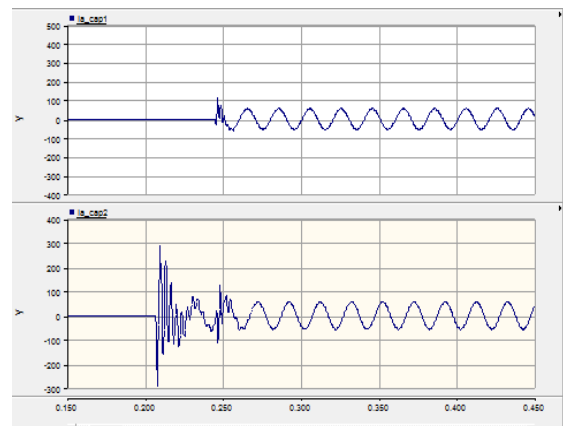



Fast switching for several 33 kV loading (12.00 hr)

Switching sequence bank one to two

Switching sequence two to one

3 ms delay

3 ms delay

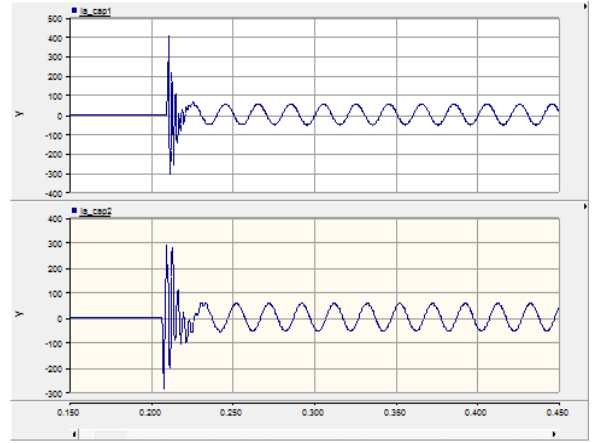
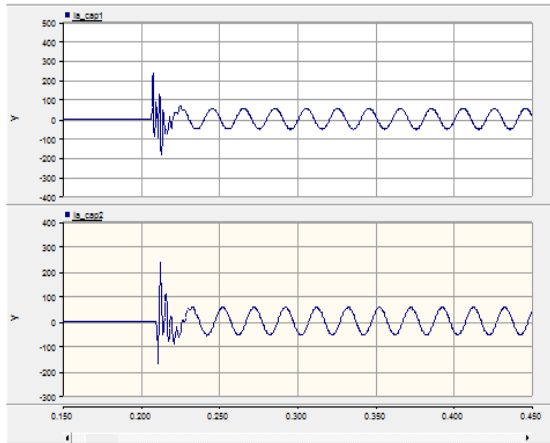

11 ms delay

29 ms delay

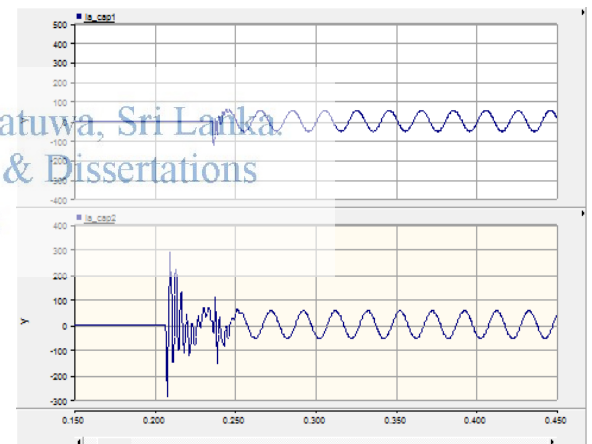
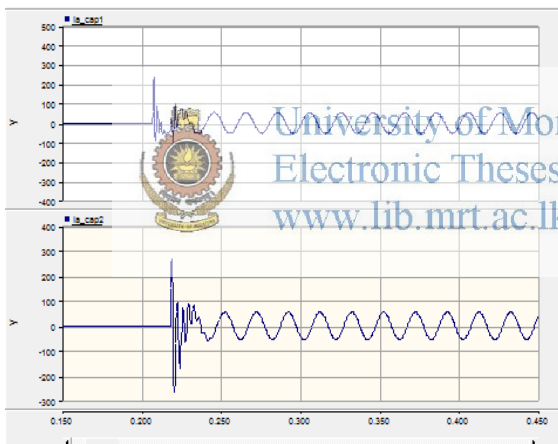

18 ms delay

38 ms delay

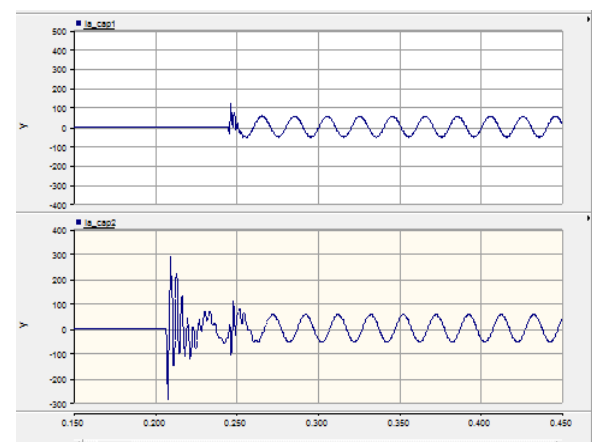
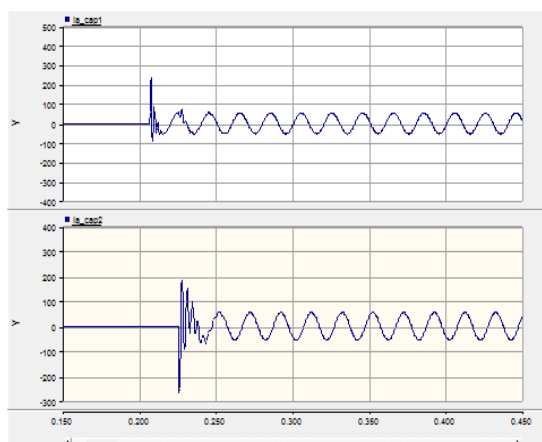

Fast switching for several 33 kV loading (15.00 hr)

Switching sequence bank one to two

Switching sequence two to one

3 ms delay

3 ms delay

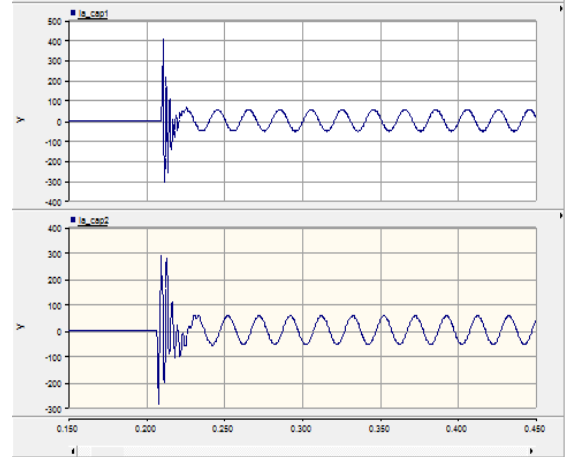
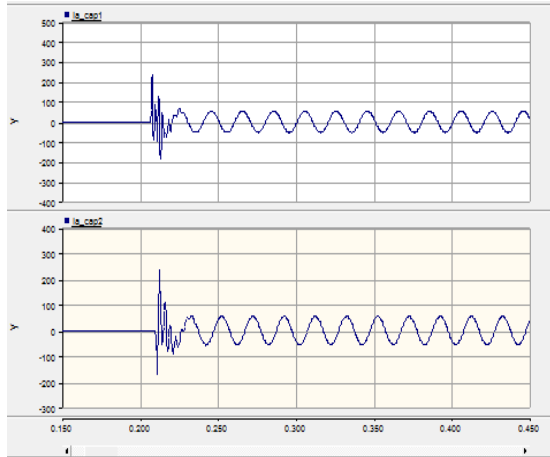

11 ms delay

29 ms delay

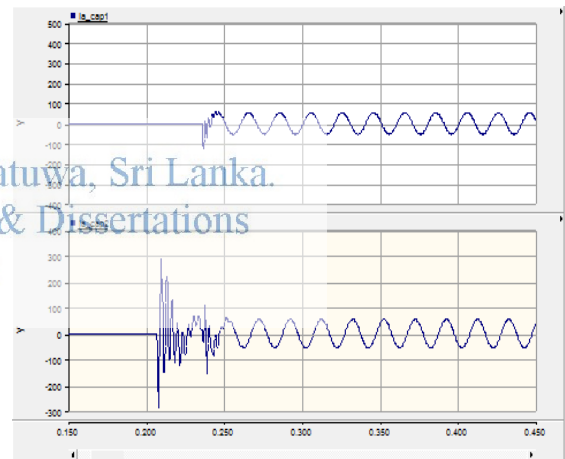
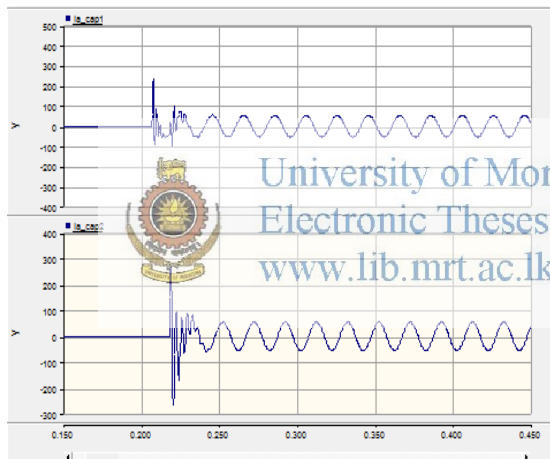

18 ms delay

38 ms delay

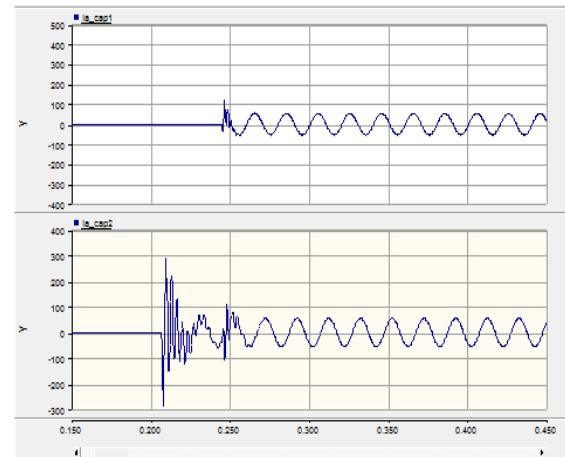
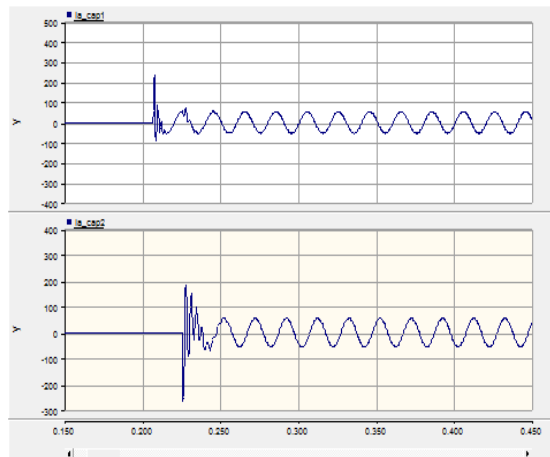

Fast switching for several 33 kV loading (17.00 hr)

Switching sequence bank one to two

Switching sequence two to one

3 ms delay

3 ms delay

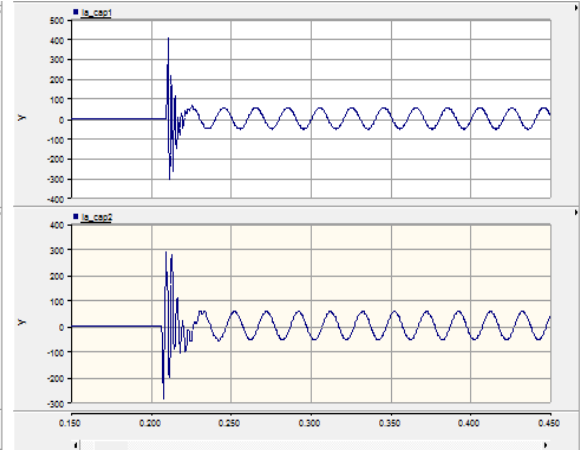
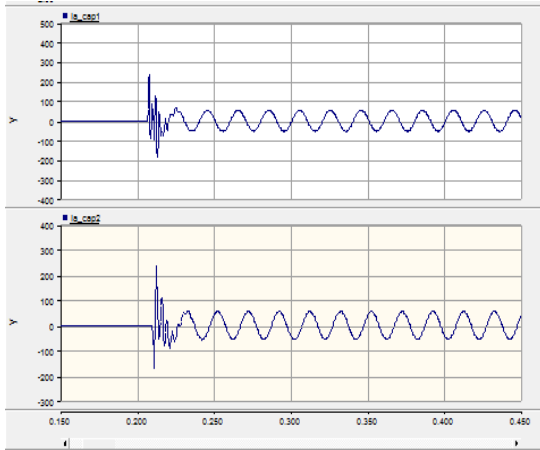

12 ms delay

28 ms delay

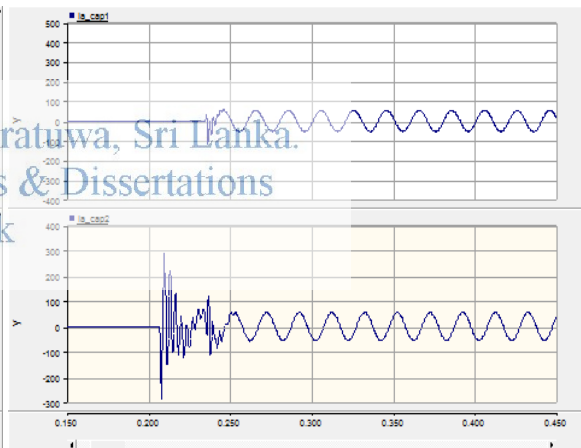
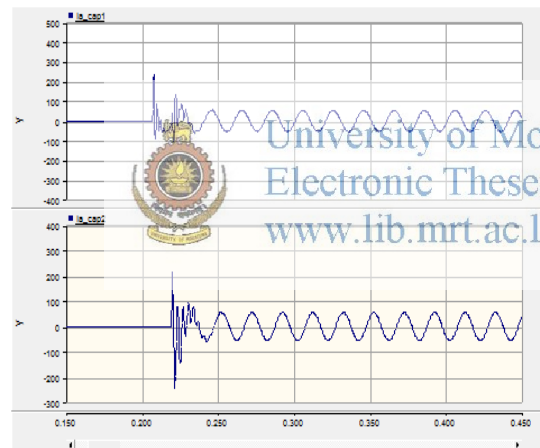

18 ms delay

38 ms delay

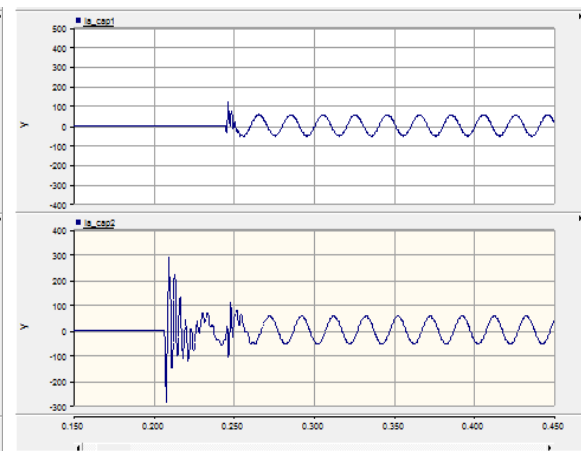
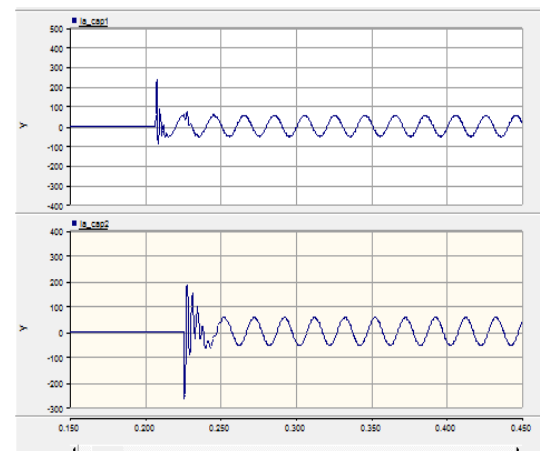

Fast switching for several 33 kV loading (19.30 hr)

Switching sequence bank one to two

Switching sequence two to one

3 ms delay

3 ms delay

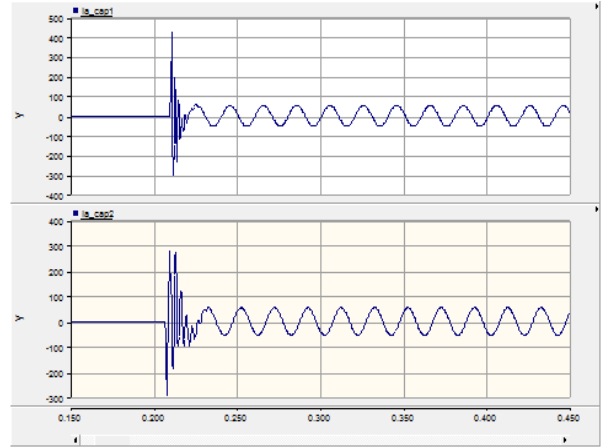
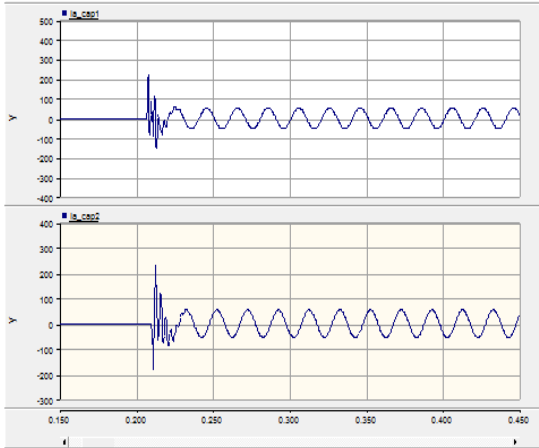

8 ms delay

27 ms delay

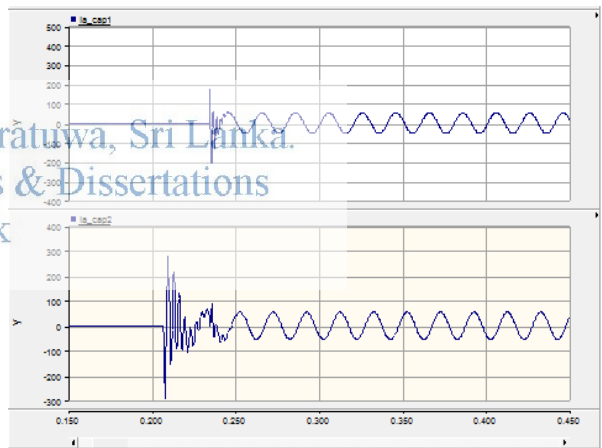
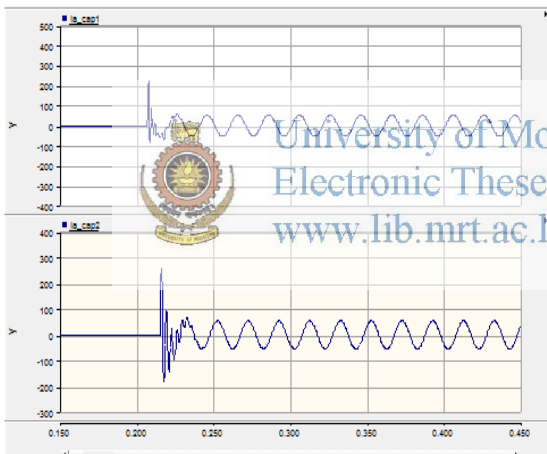

18 ms delay

38 ms delay

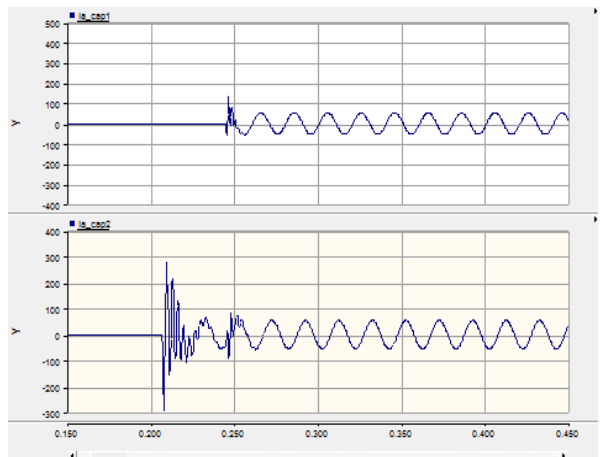
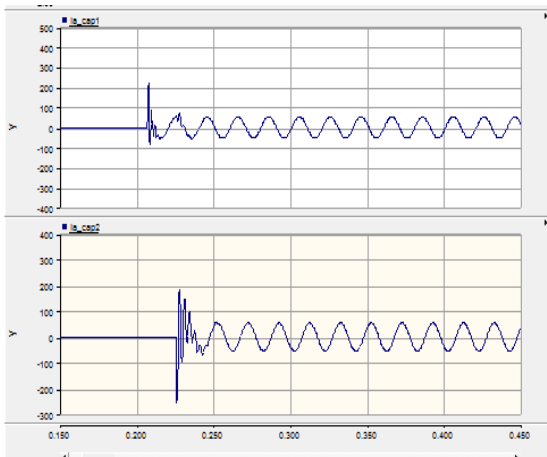

Fast switching for several 33 kV loading (21.30 hr)

Switching sequence bank one to two

Switching sequence two to one

3 ms delay

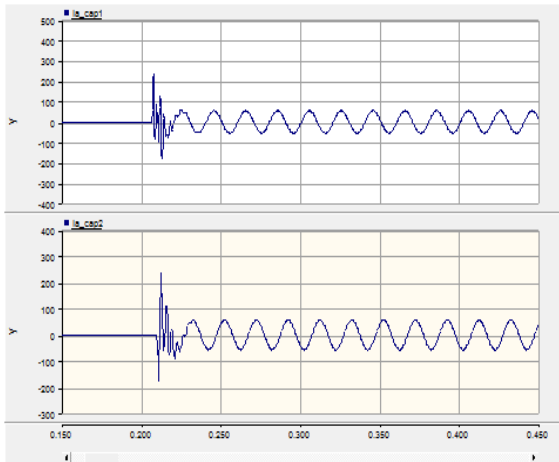

3 ms delay

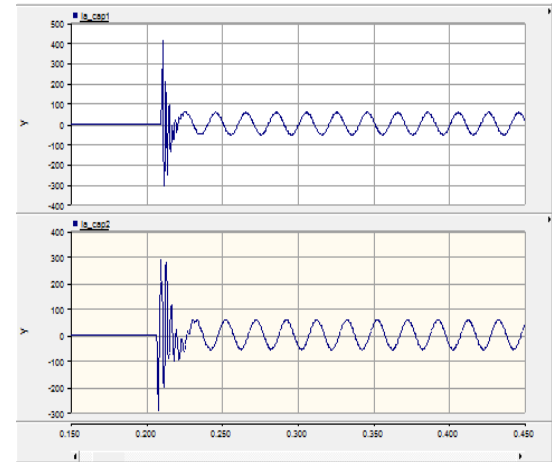

11 ms delay

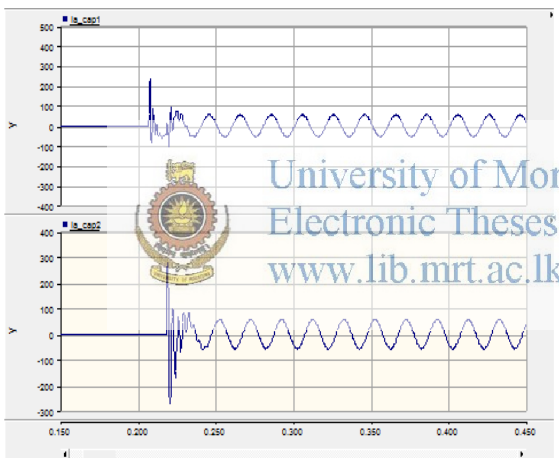

28 ms delay

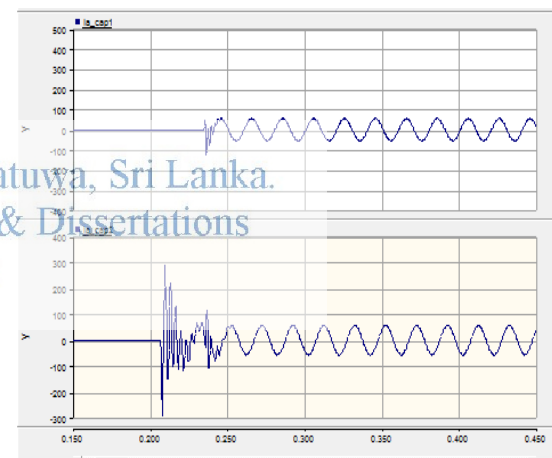

18 ms delay

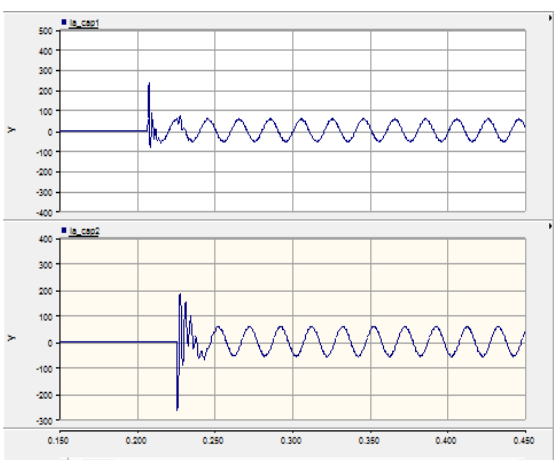

38 ms delay

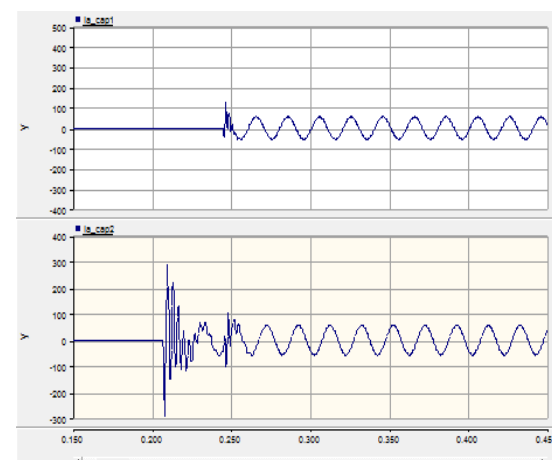

Fast switching for several 33 kV loading (23.00 hr)

Switching sequence bank one to two

Switching sequence two to one

3 ms delay

3 ms delay

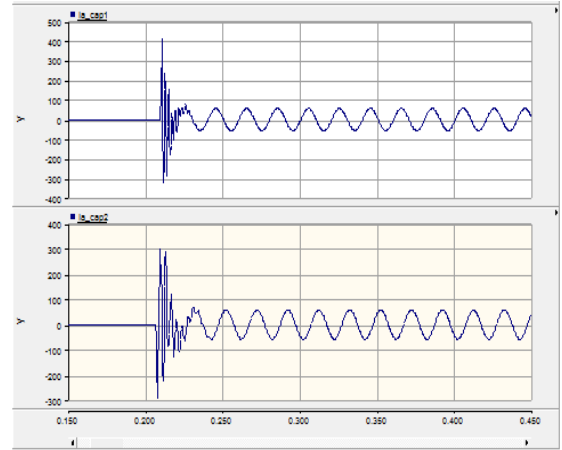
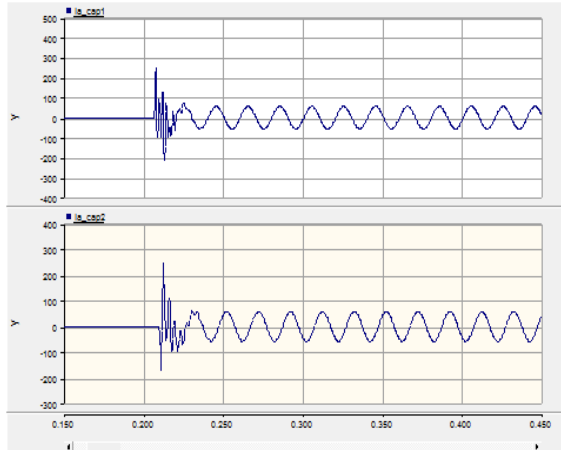

14 ms delay

30 ms delay

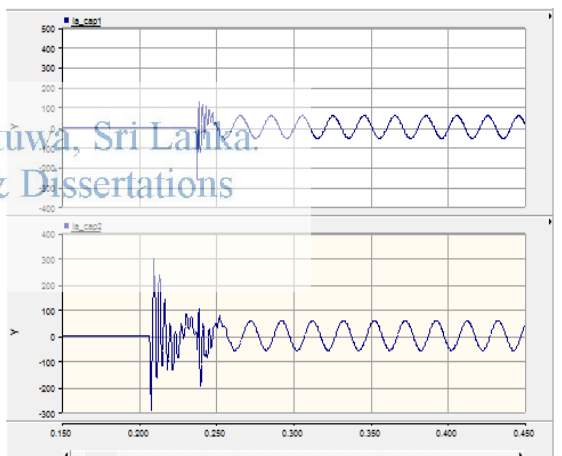
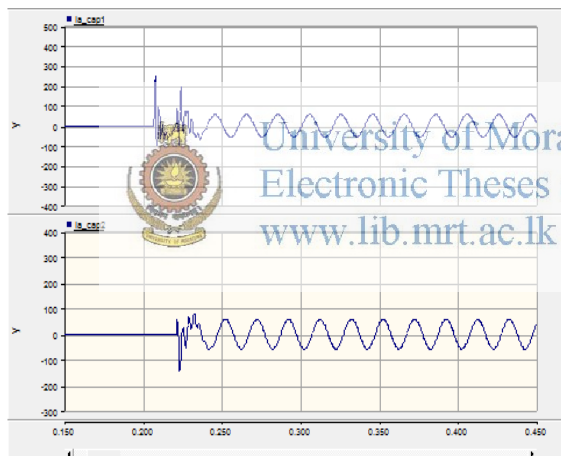

18 ms delay

38 ms delay

