

# **Design and Implementation of an Automatic Wire Cutting and Striping Machine for Small Scale Industry**

Sivasangar Kanagalingam

(148468P)

Thesis submitted in partial fulfillment of the requirements for the degree of  
Master of Electronic and Automation.

Department of Electronic and Telecommunication Engineering

University of Moratuwa  
Sri Lanka

July 2019

## Declaration

I declare that this is my own work and this thesis does not incorporate without acknowledgement any material previously submitted for a degree or diploma in any other university or institute of higher learning and to the best of my knowledge and belief it does not contain any material previously published or written by another person except where the acknowledgement is made in the text.

Also I hereby grant to University of Moratuwa the non-exclusive right to reproduce and distribute my thesis, in whole or in part in print, electronic or other medium. I retain the right to use this content in whole or part in future works (such as articles or books).

.....

Date:.....

K.Sivasangar

(148468P)

The above candidate has carried out research for the Master's thesis under my supervision.

.....

Date:.....

Dr. Chamira U. S. Edussooriya

Department of Electronic and Telecommunication Engineering

University of Moratuwa, Sri Lanka.

## **Abstract**

The trend in the recent industry is to move towards automation. This is driven by a number of factors such as increasing accuracy and decreasing human errors. This dissertation provides full overview of the development and design of the automated wire cutting and striping machine for small scale industrial application. The proposed system is put into practice in real time

Manual approach is currently used to cut and measure wire that takes more time with manpower. The effectiveness and accuracy obtained by manual method is really poor. The specific aim of the automated wire - cutting system is to cut the needed wire length in the required number of parts. By utilizing the developed system, we can achieve low cost cutting with reduced cutting process time. This system is less complex in terms of user friendliness and also portable.

**Keywords:** Automatic wire cutting, transportable, cost- effective

## **Acknowledgement**

Firstly, I should like to express our sincere gratitude to my supervisor Dr. Chamira Edussooriya, from the University of Moratuwa, Department of Electronic and Telecommunication Engineering, for supporting the identification of research issues continually, formulating the conceptual model, survey data analysis, and reviewing research progress which contributed a lot to carry out the research successfully.

Also, extend my sincere gratitude to all the non-academic staff from the Department of Electronics and Telecommunications, the University of Moratuwa and my colleagues for the many ways in which they have supported me.

Lastly, I thank my loving wife and my friends for their constant support and this milestone would not be possible without their support.

K.Sivasangar

(148468P)

# Table of Contents

Declaration.....	ii
Abstract.....	iii
Acknowledgement.....	iv
Table of Contents.....	v
List of Figures.....	vi
List of Tables.....	vii
List of Abbreviations.....	vii
CHAPTER 1: INTRODUCTION.....	1
1.1 Overview of the Research.....	1
1.2 Background and Motivation.....	2
1.3 Research Objectives.....	3
1.4 Contributions to the Small-Scale Industry.....	3
1.5 Literature Review.....	4
1.5.1 Structure and Working Principle of PLC.....	6
1.5.2 Stripping Machine Control System.....	7
1.5.3 Hardware Design and Software Design of Stripping Machine Control System.....	7
1.5.4 Existing Technologies in the Automatic Wire Cutting Machine.....	8
1.5.5 Existing machine available in different scales of industrial market.....	9
CHAPTER 2: DESIGN AND IMPLEMENTATION OF THE SYSTEM.....	11
2.1 Block Diagram of proposed system.....	11
2.2 Top View of Proposed System.....	14
2.4 Assembly of Mechanical System.....	15
2.4.1 Guide Tube.....	15
2.4.2 Wire cutter.....	15
2.4.3 Controlling speed of wire cutting and strip machine.....	16
2.5 Calculation.....	18
2.5.1 Calculation for Torque.....	18
2.5.2 Stepper motor Transfer function derivation.....	21
2.5.3 Plotting the Root Locus of a Transfer Function.....	28
2.5.5 Stepper motor Torque Vs Speed analysis and calculation.....	33
2.6 Component Analysis for the Proposed System.....	37
2.6.1 Arduino Uno board.....	37
2.6.2 12 DC wiper Motor.....	37
2.6.3 Dc Motor Driver.....	38
2.6.4 Stepper motor.....	38
2.6.5 Stepper motor driver.....	39
2.6.6 Step down converter.....	39
2.6.7 Servo Motor.....	39
CHAPTER 3: EXPERIMENTAL RESULTS AND DISCUSSION.....	40
3.1 Output and Results.....	40
3.1.1 Analysis between speed and Accuracy of the System.....	41
3.2 Cost Analysis.....	41
3.2.1 Cost comparison.....	44
3.2.2 Productivity comparison.....	44
3.3 Limitations.....	44
CHAPTER 4: CONCLUSION AND FUTURE WORK.....	45
4.1 Conclusion.....	45
4.2 Future Scope.....	45
REFERENCES.....	46

## List of Figures

Figure 1: Constitution of PLC [8] .....	6
Figure 2: PLC input and output wiring diagram of stripping machine control system [8] .....	8
Figure 3: ARM LPC2148 controller [9].....	8
Figure 4: Actual view of wire cutting machine [2].....	9
Figure 5: Existing wire cutting machine [11] .....	9
Figure 6: Existing small-scale machine [13] .....	10
Figure 7: Block diagram of proposed system .....	11
Figure 8: Flow chart of the system .....	12
Figure 9: Front view of the panel board .....	13
Figure 10: Top view of proposed system [12] .....	14
Figure 11: Wire feeding detail diagram .....	14
Figure 12: Wire feeding detail diagram .....	15
Figure 13: Stepper motor pulley specification [14] .....	15
Figure 14: Speed vs torque characteristics [15] .....	16
Figure 15: Speed vs pull torque [15].....	16
Figure 16: pull out torque vs motor speed [15] .....	17
Figure 17: With stepper motor, torque increases as the speed of the motor is reduced [15].	17
Figure 18: Stepper motor top view .....	18
Figure 19: Stepper motor torque calculation .....	19
Figure 20: Wire cutter .....	20
Figure 21: Flux loop of stepper motor [16] .....	21
Figure 22: Dynamic response of the rotor [16] .....	22
Figure 23: Closed loop feedback system [16] .....	24
Figure 24: Control system .....	25
Figure 25: Step angle vs time .....	25
Figure 26: Closed loop system with PID controller .....	26
Figure 27: Step angle vs time .....	26
Figure 28: Step angle vs time .....	27
Figure 29: Root locus output .....	28
Figure 30: Root locus output .....	29
Figure 31: Root locus output value K.....	30
Figure 32: Step response .....	31
Figure 33: Control system designer output .....	31
Figure 34: Closed loop encoder feedback system .....	32
Figure 35: Performance curve of nema 17 stepper motor[17] .....	33
Figure 36: Motor power vs speed.....	35
Figure 37: Stepper motor steps vs length calculation .....	36
Figure 38: Wiper motor specification [15] .....	37
Figure 39: stepper motor nema17 [16] .....	38
Figure 40: LM296 circuit diagram [17].....	39
Figure 41: Required feet vs error .....	40

## List of Tables

<i>Table 1: Specification of existing wire cutting machine</i> .....	9
<i>Table 2: Specification of existing small-scale wire cutting machine</i> .....	10
<i>Table 3: Steps vs distance</i> .....	35
<i>Table 4: Required feet vs error</i> .....	40
<i>Table 5: Speed vs error</i> .....	41
<i>Table 6: Required feet vs working hours</i> .....	43
<i>Table 7: Number of panels vs number of hours</i> .....	41
<i>Table 8: Cost analysis for wire cutting machine</i> .....	44
<i>Table 9: Small scale machine vs large scale machine</i> .....	44

## List of Abbreviations

ARM - Advanced RISC Machines  
CPU- Central Processing Unit  
DC - Direct Current  
IC - Integrated Circuit  
LED - Light Emitting Diode  
LCD - Liquid Crystal Display  
MEP - Mechanical, Electrical and Plumbing  
PIC- Programmable Integrated Circuit  
PLC - Programmable Logic Controller  
RPM – Revolutions Per Minute

# **CHAPTER 1: INTRODUCTION**

Chapter 1 illustrates the underlying study's motivation. The project will develop an automated system for wire cutting and stripping. Section 1.1 deals with the background and motivation of the thesis. Section 1.2 defines the research work accurately in terms of the dissertation initial approach. Section 1.3 presents the project's objective. In addition, the research contribution to society is discussed in Section 1.4.

## **1.1 Overview of the Research**

In electrical industry, there is huge demand for wire cutting and stripping process. In order to complete the process in efficient way, wires should be measured and cut accurately along with stripping process. Currently, wire measurement and cutting process are traditional and human efforts are required for it. The proposed system will replace the traditional process via automation [1], [2].

The project is based on Arduino platform which can easy to use and flexible. The system can measure wire length accurately as per given input. The motors are driven by Motor controller with required speed (revolution per meter). The cutting tool is precisely designed to measured wire length in proper format.

The user can decide the wire length according to the requirement. This project is proposed to solve the above-mentioned problem in order to minimize human efforts and avoid wires wasting. This system can measure the wire length accurately and the cutting machine can cut the amount of wires required. Using proper keypad input, the system operates very flexibly and displays the given input on LCD.



## **1.2 Background and Motivation**

The research focuses on a particular small-scale electrical industry which is established in Sri Lanka. The organization, which was taken for case study managing projects with lots of manual process and specially in wire cutting and stripping process. The labor market is a crucial problem in these types of developing small-scale industries. Most of the time labors do not take part in such work, even though companies have arranged subcontractors to finish the work. The time required to cut various length wires also depends on the worker's effectiveness. Quality depends on the worker's accuracy and ability. As a result, due to the missed deadlines, the company has to bear the big loss and lose reputation.

Once various electrical and electronics industries have been investigated, it can be concluded that up to a certain degree organization have been using automated systems. But because of budget constraints, human resources are considered too carried out in some fundamental processes in small industries.

The author has found a better way to resolve labor shortage, save time, costs, improve accuracy, and to reduce human errors [2], [3] in order to address these issues. Also, the company's production and profit margins will also be successful, as it improves the system in many various ways.

### **1.3 Research Objectives**

The main objective of this project is to investigate and develop an appropriate automation system that can operate the wire cutting and stripping process independently. Appropriate cost-effective control units and parts are investigated to ensure the accuracy of the automated system. In addition, by comparing the operational performance, the proposed system is validated.

#### **1.3.1 Goals**

The study aims to achieve the following objectives when a suitable workaround is presented.

#### **1.3.2 Main Goal**

The implementation of a cost- effective automation system to ensure that the wire cutting and stripping process is operated independently.

#### **1.3.3 Sub Goals**

1. Conception of a measurement system for wire length;
2. Designing automatic cutter and stripper;
3. Implementation of the proposed system with the required hardware and software elements in a control;
4. System validation and error identification.

### **1.4 Contributions to the Small-Scale Industry**

In Sri Lanka, the same problems are identified by large numbers of small - scale industries. Several thorough studies of the subjects were conducted separately but no study was conducted on the development of the cost - effective wire cutting and stripping system for small industries.

The targeted of the study has looked for many ways to replace traditional manual cable and stripping procedures. This research provides an automated solution the small-scale industry

## 1.5 Literature Review

The paper “Multiple blade set strip process for cable and wire” [4] explains that typical cutters consists of three blade pairs, each pair comprising two blades situated on the near side of the axis, both blades of one pair moving towards the wire to separate the wire, and the two blades of the remaining two pairs moving towards the wire sections to strip the rear and forward portions of the wire during the controlled wise movement of the sections. Generally, both blades of a pair are relocated into overlapping interactions to cut the wire. Both blades of each of the remaining two pairs are moved to cut the sheathing only on opposite sides of 50 and to strip the sheathing from the end portions of the sections as the sections are moved at the same time.

Another purpose is to displace the end wise of the two sections, thus displacing wire combining one of the segments into the first position. The technique also involves the step of dividing the parts from the end portions of the section axially relatively wise after the step of separating the wire and before the step of removing the sheathing [4]. Another goal is to guide the displacement of the wire end wise along the axis between blade combinations and in this respect, both the forward and the rear sections can be guided in this way. Also, another drive is to separate the forward and rear wire sections by advancing one section and retracting another section in relation to the one blade pair and the technique involves further separation of the sections by progressing one section further and retracting the other section in relation to each blade pair.

The paper “Apparatus for cutting and insulation stripping of an electrical cable” [5] specifically stated that the stripping blades are shorter than the cutting blades by an amount that is cut without 15, the stripping blades in the first part of the working cycle or stroke of the tool, into the electrical insulation of the wire. In addition, the cable ends produced by cutting the cable are removed from cutting blades and the retracted cable ends are set at an insulation strip length within the range determined by the highest possible insulation stripping length.

The paper “Automatic cable measuring and cutting machine” [6] describes that the drive includes conical wheels that are fitted by the extendable roller and which adjustment varies with respect to the roller speed. Throughout the belt roller and adjustable roller, this system reverses the process by maintaining a constant predefined length of output while changing the input on the number of belt rotation and the roller surface area is not critical because the cable should be moved exactly 10 ft. speeding belt can be accounted and the system altered by

physically measuring the completed product to a correct dimension for cables with a different stretch characteristic. Standard metrics use a circumference wheel with one foot and the engine can be fitted with a magnetic, electrical or variable velocity drive brake for soft start and stop movement. Also, it elaborates the controllers are fitted with a relay that opens up to stop or slow the motor down.

The paper “Wire length measuring and cutting apparatus” [7] explains that the counter-reverse feeding clips in the apparatus of the type specified must be accurately synchronized in order that their operation, i.e. their feeding and return strikes must be of equal length and one clip must be reached by the end of the feeding stroke when the other clip is reached at the end of the return stroke. In addition, when moving in their respective end positions, couples of wires grabbing masks traveling back and forth in conjunction with feeding clamps must be precisely timed so that they open and close as required.

The Author of “Wire preparation machine with variable insulation stripping mechanism” [8] says that the main objective of this invention is to provide a wire making machine of the type described earlier with an improvement of the plurality of cut and streaked wires for providing, each of which has a different length of exposed conductor at a certain scheduled sequence. Also, the improvements involve a mounting device for the mounting of the strip ping mechanism in respect of the cutting mechanism so that the distance between it is varied, and a control device for programming the distance the strip by mounting methods

As we all know, the control technology (PLC), the programmable logic controller, has quickly evolved. It can be utilized to operate industrially controlled systems, including the operation of the floating points, high-speed counting, interruption counting, PID and networking. Ladder is the most widely used language in PLC programming. The PLC ladder diagram with the relay control circuit is quite similar, but the PLC control and relay controls have certain differences, particularly in the following elements. The PLC utilizes its internal memory for the program, so we can easily change the program and change the control logic [8].

The relay control is done by mechanical relay contacts, and contacts usually open and close in tens of milliseconds. Semiconductor circuits provide the PLC Control Logic with program commands and the general command is in microseconds. The logic of limit relay control uses the time relay to control time, low time accuracy, environmental sensitivity and difficult modification. In order to achieve high time accuracy, from 0,001s to several minutes, which

could be used for timing control by preparation, the PLC semiconductor is integrated with a circuit timer and it is very expedient. The logic of count relay control usually has no counting function, but the PLC program has counting function.

PLC is optimized for industrial control and computers are designed for scientific computing and data processing, using computer-type architecture but mainly reflecting the following aspects. In addition to the control fields, computer technology applies to scientific computing, data processing, computer communication etc. General computer needs high environmental conditions while PLC can be implemented to low environmental industrial sites. The basic computing programming has immense programming languages for complex applications, such as assembly language, C language, etc, with high programmers' requirements, while PLC offers low logic programming languages, which are simple, easy to learn and operate. PLC is pretty slow in general computing speed [8].

### 1.5.1 Structure and Working Principle of PLC

Figure 1 lists PLCs and computers as the core compartment of the PLC-based control system. These are mostly centralized processing unit (CPU) and memory interface, power supply and components.

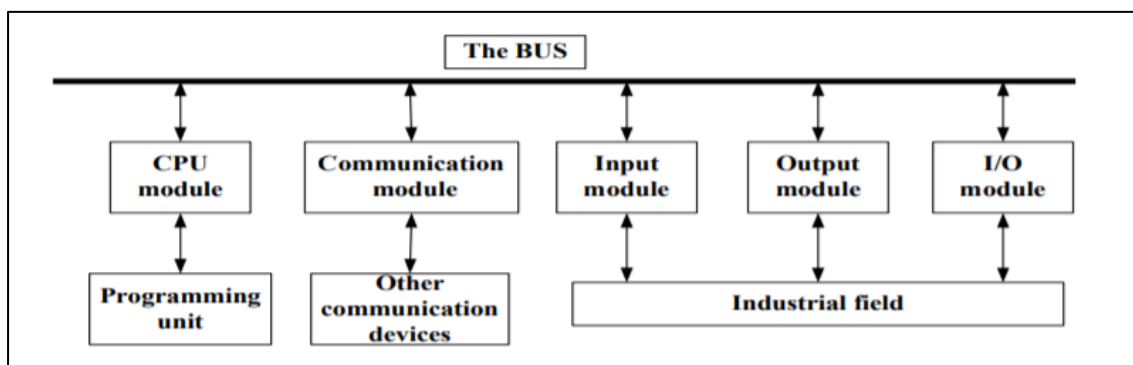

Figure 1: Constitution of PLC [8]

PLC has two modes of operation-RUN and STOP. In RUN mode the user can perform control processes by running the program and in STOP, CPU doesn't run any of its user programs, it can develop and modify the user operating systems and download the user operating systems to PLC. The operation of the PLC usually divides the mechanism into three stage, which is the sample input, user execution and output refresh. A scan cycle is known as the completion of the three phases. The CPU from the PLC repeats the three phases mentioned above with a scans speed over the entire run.

### **1.5.2 Stripping Machine Control System**

Over the past few years, domestic and international manufacturers have built a number of wire strippers such as a small temple stripper C350 in Japan which is using its own special step-motion and is equipped with a full-blown, small size weighted light but the price is too high to accept for its user.

Some of China's early producers of generic Japanese products were established in the 1980s. Domestic strippers began production in the early 1990s. The electronics growth in the late 1990s meant that the stripping machine had a common stepper engine that reduced product costs and good prospects on the market. The process of stripping wire can be segmented into thread, wire fixture, stripper head, wire release, wire delivery length, wire cutting, wire feeding. Figure2 shows the architecture of the stripping machine and the stripping machine system consists primarily of three components, LCD, PLC, stepping motor. PLC acts as required to program stepper engine controls for complete system functions; certain error messages would be sent by the PLC code to the display on the screen after the decoding; stepper motor contains four motors and drives, stepper motor drive receives pulses sent by the microscope and LCD scanner; PLC operates as necessary for the program to control stepper motor in order to complete system functions [8].

### **1.5.3 Hardware Design and Software Design of Stripping Machine Control System**

The stripping machine control system has 36 inbound buttons and 3 sensors, indicating that a total of 39 inputs are available. In this way, the system is design-specific. The stripping system consists of nine inputs, that are 9-point inputs which are required for the PLC; the output of the PLC mainly controls 4 steppers and error information coding which requires a 16-point output. The PLC input and output cable schedule is illustrated in depicts stripper control system program, the two-stage striping program is shown in Figure 2, with the threshing striping program nearly the same as two-stage stripping.

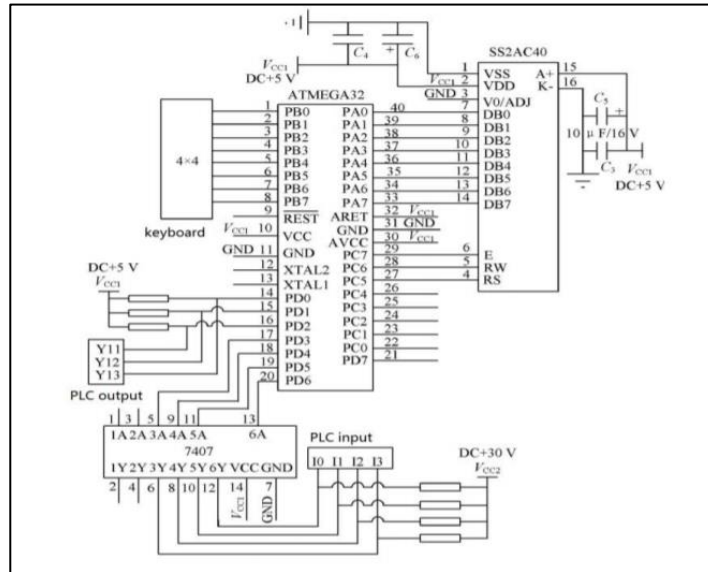

Figure 2: PLC input and output wiring diagram of stripping machine control system [8]

## 1.5.4 Existing Technologies in the Automatic Wire Cutting Machine

### Method-01

#### Automatic wire cutting system using ARM controller.

ARM 7 IC, LCD, Stepper, DC motor, wire sensor are the key elements used in this system. IC of the ARM module is commonly used for LPC2148 (ARM IC). Also, pre-configured with many built in peripherals, thus enabling both novices and high-quality application developers to be more efficient and dynamically automatic [9].

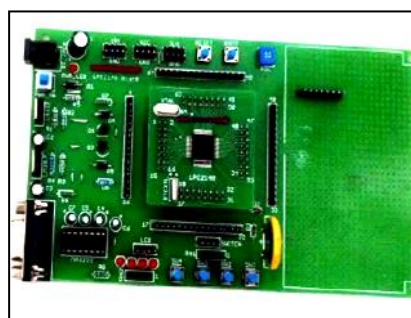

Figure 3: ARM LPC2148 controller [9]

### Method-02

#### Automatic wire cutting system using PIC Microcontroller.

In this system, user can choose the length of the wire as required. An integrated colour tracking system with an automatic wire trimming machine for isolated electric wire to be cut. The cables would be used in the Wire Harness module. The sub modules that make up the required

application together are depicted. System development is carried out using image analysis, computational physics, the computing micro controller and hardware [10].

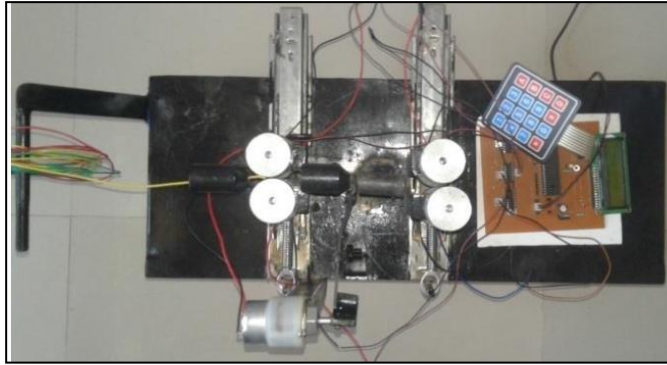

Figure 4: Actual view of wire cutting machine [2]

### 1.5.5 Existing machine available in different scales of industrial market

#### ➤ Large Scale Industry



Unit price = US \$8000.00
Shipping charge =US \$227.49
Total cost = US \$8227.49

Figure 5: Existing wire cutting machine [11]

Product name	computer wire stripping machine
Model	X-501B
Weight	Head 0~35mm,Tail 0~15mm
Overall Dimensions	390mm*350mm*235mm
Power	160-300W
Screen Mode	Crystal LCD Screen
Cutting Length	1mm ~ 9999mm
Tolerance reduction	$L^* \leq 0.002$ [L = Length of cut ]
Speed of removal	3000 ~80000 pcs /h
Adjusting Speed	0 Slowest, 9 Fastest

Table 1: Specification of existing wire cutting machine [12]



PLC acquires the state of sensors such as data on the diameter to control the operation of the parts of other machinery in order to form a shutting down loop between a PLC control system and the grinding sensors of the motor [3]. The solution requires 9 various methods of achieving requirements in processing, the difficulty lies with PLC's accurate control of four step - motors in the design of high - speed signals. In order reduce the cost, 36 input keys in hardware design, which are converted to six -way PLC inputs by matrix - encoding. The article uses a ladder formed speed control and retardation curve control method, with a compact design of the PLC program, to ensure accurate control of the stepper engine to prevent the loss in the engine and increase the robustness and accuracy of stepper engine.

➤ **Small Scale Industry**



Unit price = US \$3500.00
Shipping charge =US \$400
Total cost = US \$3900.00

Figure 6: Existing small-scale machine [13]

Name	automatic cable cutter/wire stripping machine
Model	HRG-2830-2C
Condition	New
Power supply	AC110V/220V 50/60Hz
Cutting length	0.1-60000mm
Stripping length	Head 0.1-180mm,Tail 0.1-99mm
Cutting tolerance	±(0.002*L)mm (L=cutting length)
Drive way	Four wheels drive
Wire stripping range	0.1~35 mm <sup>2</sup>
Speed	2000-8000pcs/h
Wire pressure regulation	Yes
Display	LCD display with English menu
Size	450*380*350mm
Net weight	50kg

Table 2: Specification of existing small-scale wire cutting machine [13]

## CHAPTER 2: DESIGN AND IMPLEMENTATION OF THE SYSTEM

This Section describes how the proposed system is designed with hardware platform. The block chart of the system is presented in Section 2.1, and the top view of the board is shown in section 2.2. The front view of the panel board is described in Section 2.3. 2.4 and 2.5 elaborates the fabrication of the system and calculation between manual process and automated process.

### 2.1 Block Diagram of proposed system

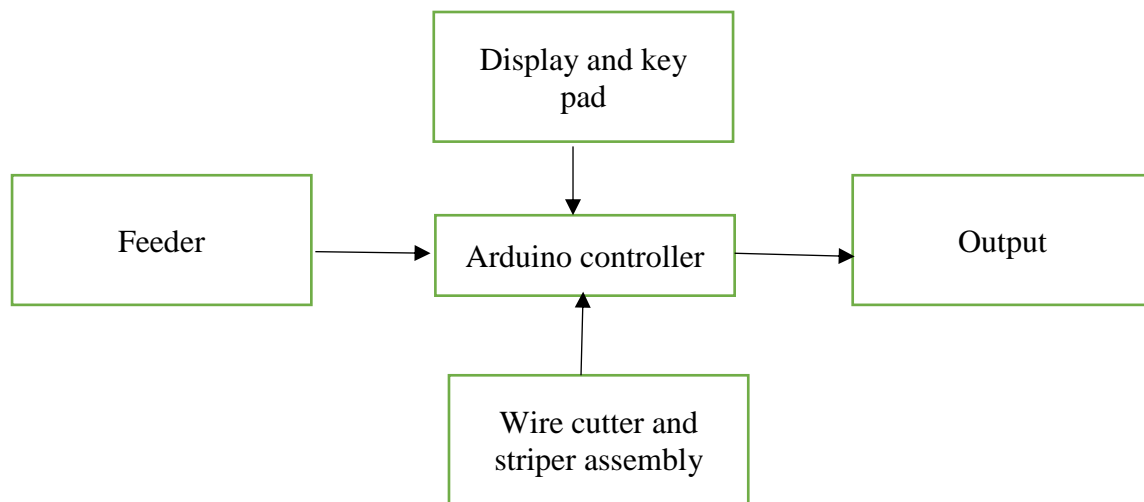

*Figure 7: Block diagram of proposed system*

The *Figure 7* above shows the entire system block diagram. The Arduino, which works on the inputs and controls the various connected devices, is the main processing unit in the system. The system's input is entered through the keyboard and is shown on the system's LCD display. As the user input, the centimeter length of the wires and the necessary number of wires are taken. The system also monitors the existence of wire.

The Arduino controls the relays that drive the stepper motors to pull the wire within the guide when Enter is pressed into the keyboard. The cable moves forward at an exact distance with a rotation of the motor. This method allows the exact length of the wire to be cut. The cutter connected to the lower DC engine is triggered to make an exact cut at certain correct intervals. The system also shows the number of wires remaining on the display for cutting.

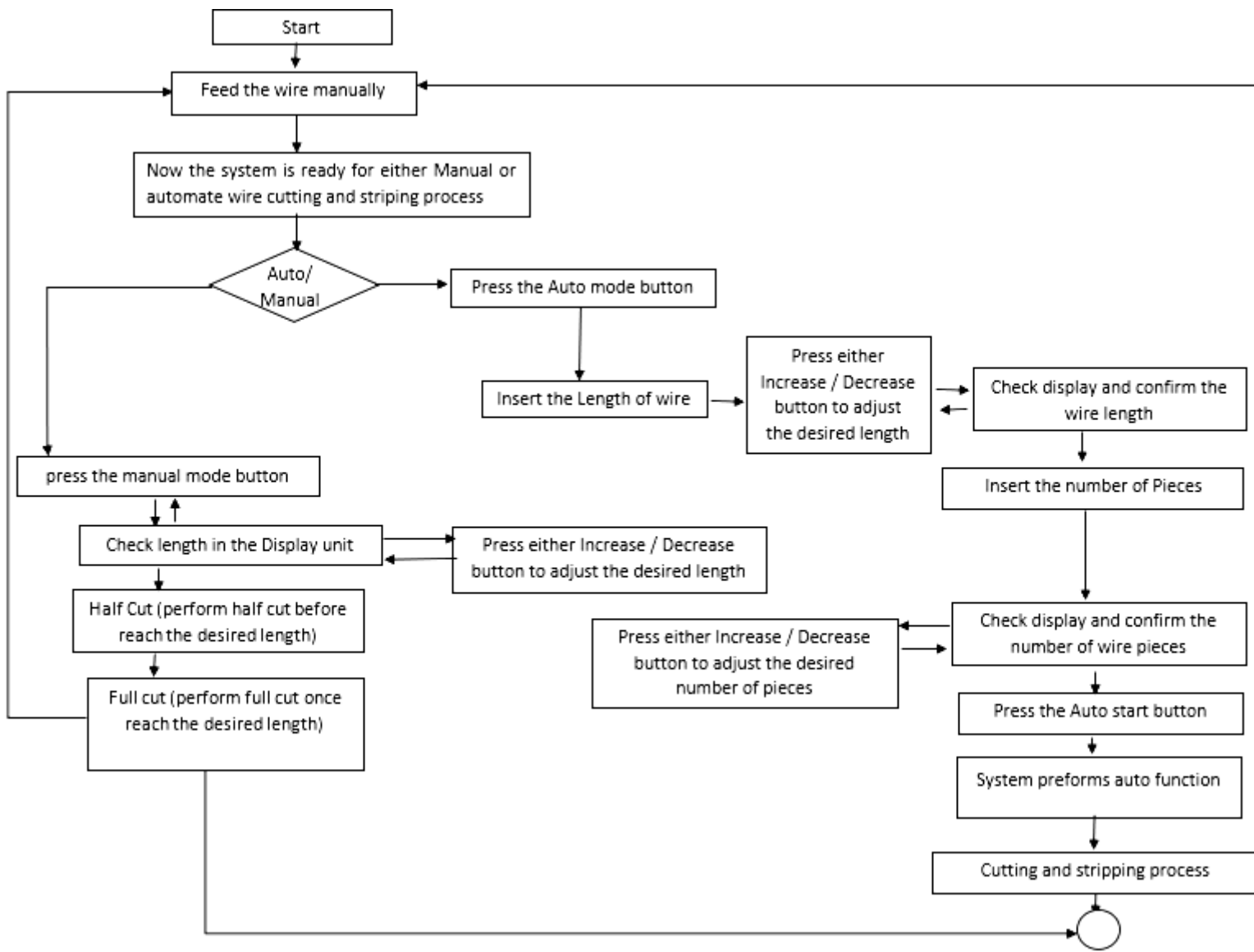

Figure 8: Flow chart of the system

Figure 8 above explains the system's process flow. As I mentioned in the diagram, the wire must be fed manually at the beginning and the mode should be selected (Auto / Manual) via button number 04. If we choose manual mode that means that we prefer to carry out wire - cutting and stripping manually and continue to press the forward button (button number 05) to measure the length on the LCD and then, before we have reached the required length, press full cut button (button number 08) to pull the cord off. By selecting Automate mode (button number 04), we can perform the automatic process of cutting and stripping, which is the ultimate objective of the system, and before the automated process we should define some values which are wire length via button number 09 or 10 and number of wires via button number 11 or 12. Once we enter those values; we should press the auto-start button (button number 13) and then it will automatically start the wire cutting and stripping process as we defined. In any instance, if we want to stop in the middle of the process, we can press stop button (button number 14) to terminate the function.

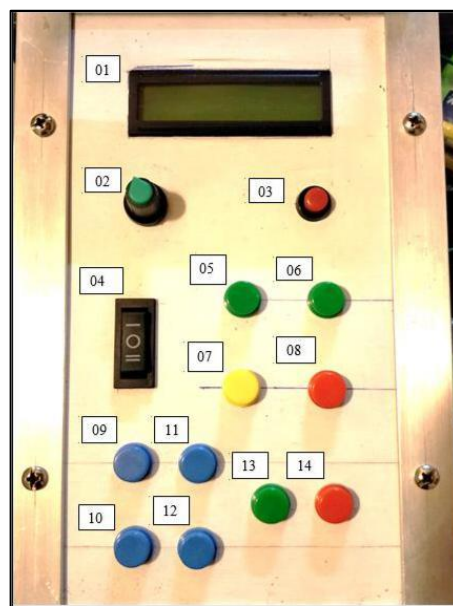

Figure 9: Front view of the panel board

- |                                 |   |
|---------------------------------|---|
| 01- Display                     | 02- Speed controller                                |
| 03- Reset                       | 04- 3-way switch (I- Manual Switch, O- Auto switch) |
| 05- Forward                     | 06- Backward  |
| 07- Half cut                    | 08- Full cut  |
| 09- increase the length         | 10- Decrease the length                             |
| 11- Increase the number of wire | 12- Decrease the number of wires                    |
| 13- Start                       | 14- Stop  |

## 2.2 Top View of Proposed System

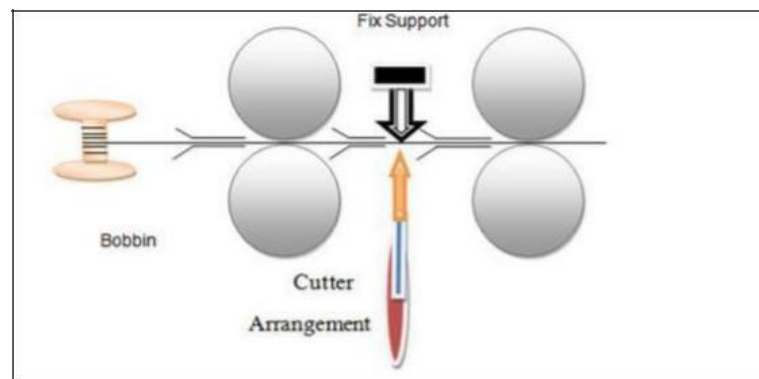

Figure 10: Top view of proposed system [12]

The above *Figure 10* shows the top view of the system block diagram. It includes a bobbin placed on a bobbin mount. Then cable passes the very first cable guide channel to lead a cable towards cable cutting. The roller is being used for passing the wire forward section according to the programming, either clockwise or counterclockwise [11]. In this respect, the wire is passed by four rollers into forward sections. As shown in the block diagram of the top view of the proposed system, the rollers are arranged, and cutter are fixed between the roller layout and the cable guide as shown in *Figure 11*.

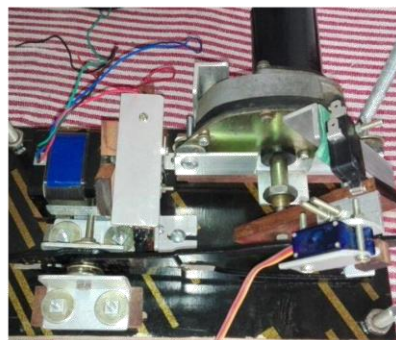

Figure 11: Wire feeding detail diagram

## 2.4 Assembly of Mechanical System

This study aims to use the wire cutting machine. Base for the entire system has been designed during the initial phase of the project. Underneath stepper motor is mounted in the base. The system uses two brackets which are made from a slab with several operations such as exterior rotation, faceting, centering, 0.5 mm growing, 40 mm diameter machining, boiling and tapping, . Also, it has two rollers in the system. The guide pipes are attached on a support of the column which is sold on a 2 mm thick basis. The total guide tube length is 38 mm and the inner diameter of the taper is 8 mm.

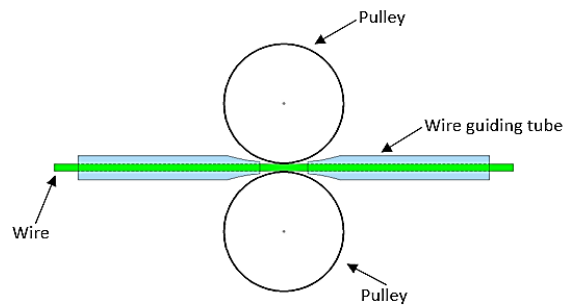

Figure 12: Wire feeding detail diagram



Figure 13: Stepper motor pulley specification [14]

### 2.4.1 Guide Tube

With a diameter bar of 21 mm up to 12 mm in length. Drilling of diameter 8 mm via center of guide nozzle for direct transmission and holding of cable. Guide pipes are installed at 110 mm angle bars.

### 2.4.2 Wire cutter

Support of brackets are used to support the tool. The DC engine is used to operate the tool and another motor is added in the tool to determine the way of cutting.

### 2.4.3 Controlling speed of wire cutting and strip machine

A stepper engine is a positioning device and speed device is a DC Motor. We should check the time between steps to control the speed of a stepper motor [6] and if the excess torque is sufficient to maintain it, we can regulate position and speed. The current is controlled to manage the speed of a DC motor.

$$\text{Step Rate} = 1 / (\text{Step time} + \text{Delay time})$$

$$\text{Speed} = \text{Step rate} * \text{Step Size}$$

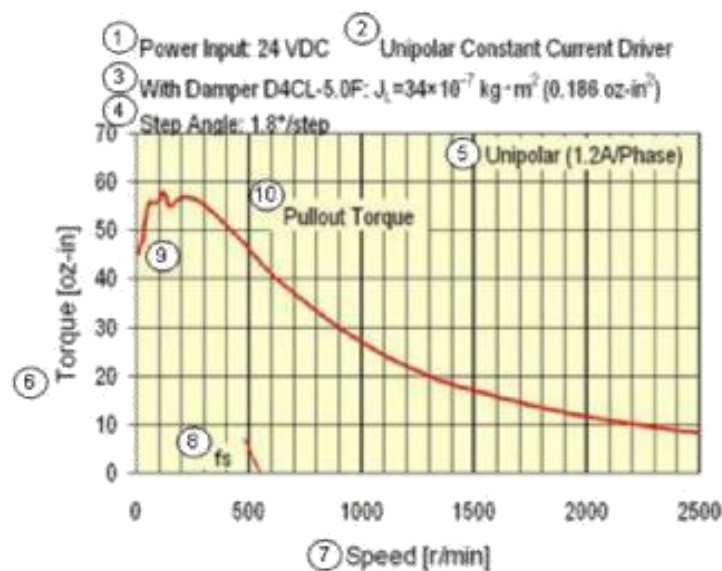

Figure 14: Speed vs torque characteristics [15]

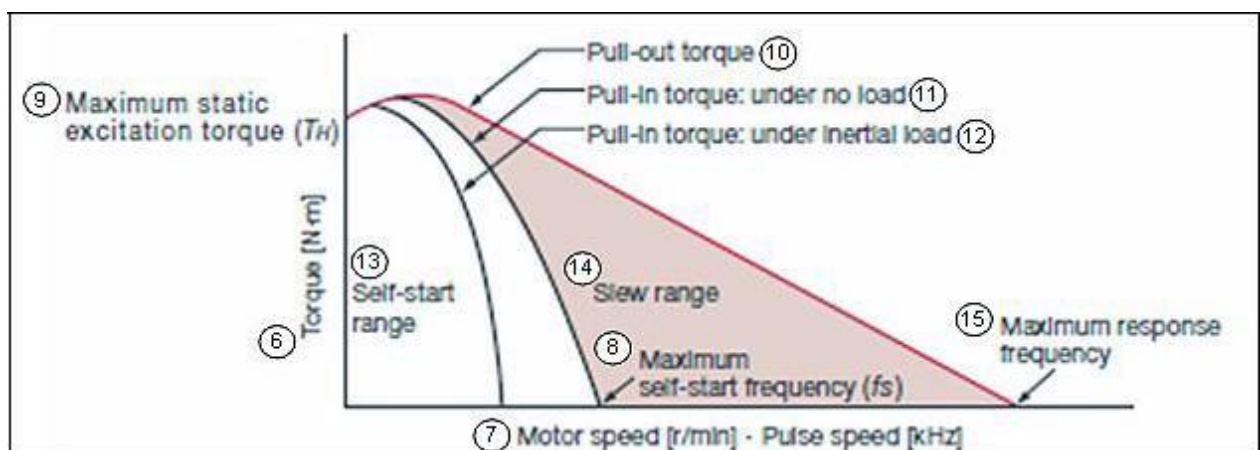

Figure 15: Speed vs pull torque [15]



Stepper motors cannot produce a working torque of that same size and weight as standard DC engines. A standard 12-volt stepper engine can have an operating torque of only 25 oz-in. The same twelve-volt typical DC engine can have three or four times more torque. But when they turn slowly, moves are very smooth. The slower the motor rotates, the higher the torque with the standard stepper. Usually the reverse applies to continuous DC engines. Figure 14 demonstrates a unipolar 12-Volt stepper running torque graph.

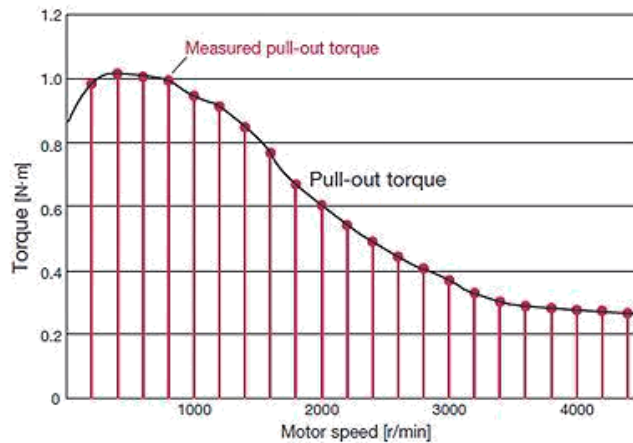

Figure 16: pull out torque vs motor speed [15]

The actuation of a stepper engine makes the shaft progress. The engine will not turn again if you keep winding. The shaft is actually locked, as if you had brakes. The braking energy of a step engine is articulated as a carrying torque. Some few oz in holding torque are used for small stepper motors. The torque surpassing 400 oz - in is held in larger, stronger models.

The same as DC engines, the voltage and current ratings of stepper engine differ. Stepper motors are not unusual for 12-volt operations. However, we don't get better performance if we provide a higher voltage than the defined voltage for stepper engine. If a stepper exceeds the rated voltage by about 80 to 100 percent, the motor can eventually be damaged.

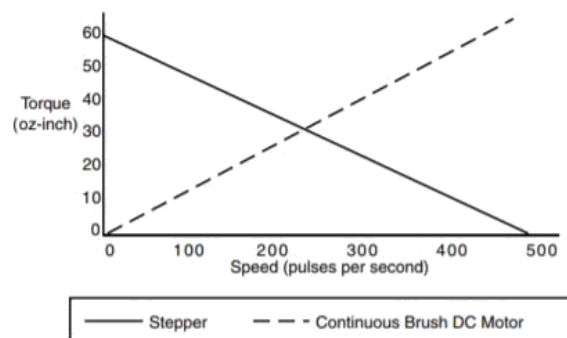

Figure 17: With stepper motor, torque increases as the speed of the motor is reduced [15]



## 2.5 Calculation

### 2.5.1 Calculation for Torque

The below mentioned Figure:18 calculations have been carried out to calculate the torque value of stepper motor which differently effects the speed of the feeding mechanism. When system feed the wire between two pulleys, it brings the torque due to the friction. So, here we calculated the torque value in order to adjust the feeding speed in the system.

Also, Figure:20 explains the calculation of the cutter's force value which determines the process of cutting and stripping in the system. Since force depends on DC motor's speed, by calculating the force of cutter, we could be able to change the speed of DC motor.

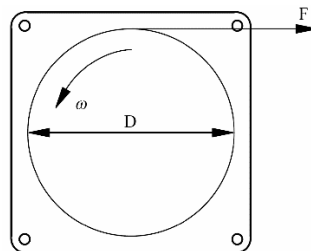

Figure 18: Stepper motor top view

Here

C: circumference of the roller

r: radius

$$\begin{aligned}C &= 2\pi r \\C &= 2 \times 3.142 \times 35 \\C &= 220 \text{ mm}\end{aligned}$$

Stepper motor Nema 17 speed = 28 rpm

Here

T- Torque of stepper motor

F- Spring force

$$T = F \times r$$

we assumed 2 kg of spring force.

$$\begin{aligned}T &= 2 \times 9.81 \times 35 \\T &= 70 \text{ Nmm}\end{aligned}$$

Here

$F_r$ - Frictional Force

$F_c$ - Clamping Force

$R_n$ - Reaction Force = 20

$\mu$ - Coefficient of friction = 0.3

$$F_r = \mu \times R_n$$

$$F_c = F_r$$

So

$$F_r = 0.3 \times 20$$

$$F_r = 6 \text{ N}$$

The loss in transmitted torque from engine to roller due to friction is expected to be 25 percent. Motor torque by taking into account 25% loss.

$$T = 700 \times 1.25 \text{ Nmm}$$

$$= 875 \text{ Nmm}$$

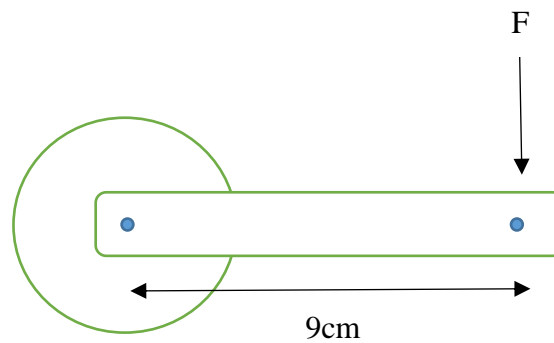

Figure 19: Stepper motor torque calculation

DC Motor Torque is 5 Nm

$$T = F \times D$$

$$5 \text{ Nm} = F \times 9 \times 0.1 \text{ m}$$

$$F = 56 \text{ N}$$

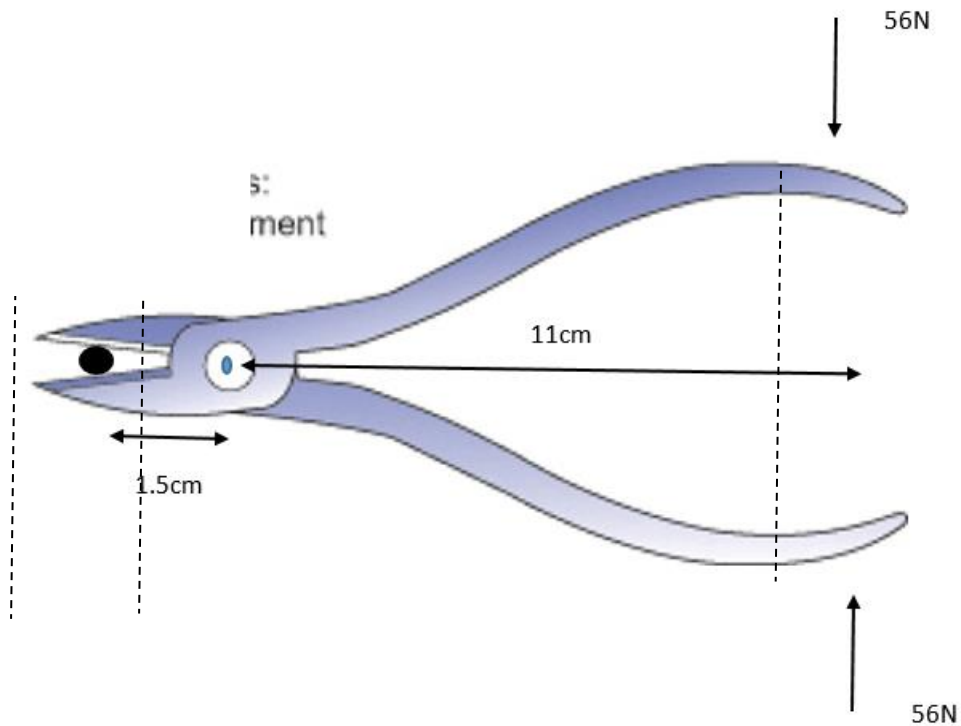
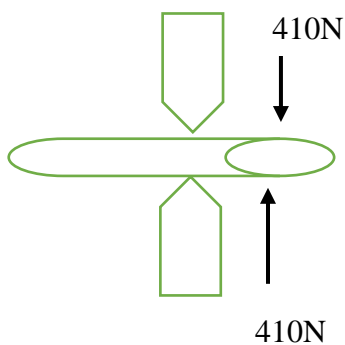

Figure 20: Wire cutter

$$\begin{aligned} \text{Movement} &= \text{Force} \times \text{perpendicular distance} \\ \text{Movement} &= 56 \text{ N} \times 11 \text{ cm} \\ \text{Movement} &= 616 \text{ Ncm} \end{aligned}$$

$$\begin{aligned} \text{Movement} &= F \times \text{perpendicular distance} \\ 616 \text{ Ncm} &= F \times 1.5 \text{ cm} \\ F &= 410 \text{ N} \end{aligned}$$



Here

P- Pressure on the wire

$$\begin{aligned} P &= F / A \\ &= 410 / \pi * 0.2^2 \\ &= 3261 \text{ Ncm}^{-2} \end{aligned}$$

## 2.5.2 Stepper motor Transfer function derivation

The following calculation explains that how we changed the open loop mechanism to closed loop in order to increase the accuracy of the stepper motor. In order to convert the open loop mechanism to closed loop, we have to derive the transfer function of stepper motor which is calculated as follow.

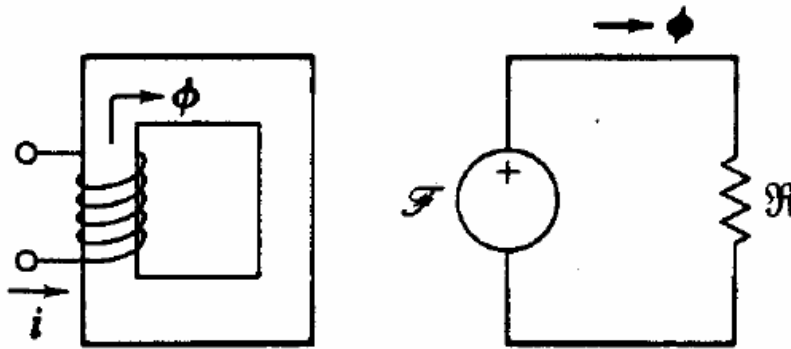

Figure 21: Flux loop of stepper motor [16]

Here:

$E_{mmf}$  –Magneto motive force

$N_i$  – Number of turns

The flow in the ferromagnetic core is dependent on the number of N spins in the core

$$E_{mmf} = N_i$$

Here:

R – Resistance phase of motor

$\Phi$  – Angular rotation

$$E_{mmf} = R\Phi$$

Here:

$A(s)$  –magnetic reluctance of a core with cross section

$\mu(s)$  – Permeability

$\mu_r$  – permeability of ferromagnetic material

$\mu_0$  – permeability of air

$$R = \oint \frac{ds}{\mu(s)A(s)} = \sum \frac{l_i}{\mu_i A_i} = \frac{L}{\mu_r \mu_0 A} + \frac{2x}{\mu_0 A} = \frac{1}{\mu_0 A} \left( \frac{L}{\mu_r} + 2x \right)$$

Step number for stepper motor

Here:

$\theta_s$  – step angle

$$S = \frac{360^\circ}{\theta_s}$$

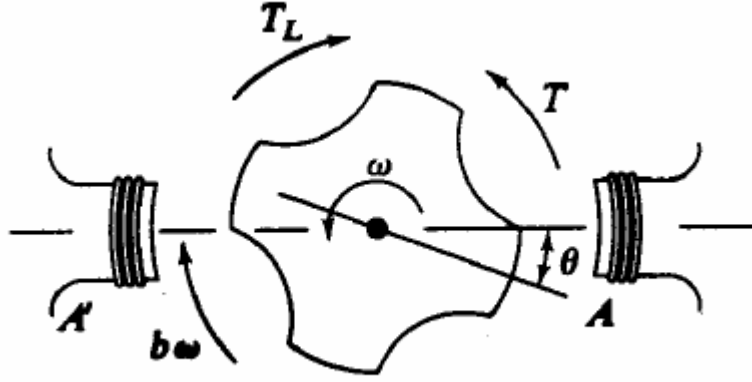

Figure 22: Dynamic response of the rotor [16]

Current in phase AA is  $i_A$

Torque extended on the rotor by phase AA is

Here:

$L_A$  – Self inductance

$n_r$  – number of teeth in the rotor

T- Torque

$$T = \frac{1}{2} i_A^2 \frac{dL_A}{d\theta}$$

$$L_A = L_0 \cos n_r \theta$$

$\theta$  and Torque are always against signs

$$T = -\frac{1}{2} i_A^2 L n_r \sin n_r \theta$$

Using Euler's second law

Here:

$T_L$  – Load torque to the motor

$J_m$  – Polar mass movement of inertia

b- Viscous damping coefficient

$$-T_L + T - b\omega = J_m \frac{d\omega}{dt}$$

$$J_m \frac{d^2\theta}{dt^2} + b \frac{d\theta}{dt} + \frac{1}{2} i_A^2 L n_r \sin n_r \theta = -T_L$$

Constant voltage  $v_0$  across the windings for phase AA

$$v_0 - i_A R - \frac{d(L_A i_A)}{dt} = 0$$

Here:

$\beta(t)$  is represented as a small difference in the current angle.

$\theta_0(t)$  from a desired angle of step  $\theta_i$

$$\beta(t) = \theta_0(t) - \theta_i$$

Find the current  $i_A(t)$

Here:

$i_0$ - Constant stationary current required to maintain the angle  $\theta_i$

$y(t)$ - the small deviation in current corresponding to the deviation  $\beta(t)$

to linearize the equation,  $\theta(t) = \beta(t)$ ,  $T_L = 0$ , and neglecting all products of small terms

$$\begin{aligned}
 i_A(t) &= i_0 + y(t) \\
 J_m \frac{d^2\beta}{dt^2} + b \frac{d\beta}{dt} + \frac{1}{2} i_0^2 L n_r^2 \beta &= 0 \\
 (L_0 + L) \frac{dy}{dt} + R y &= 0 \\
 J_m \frac{d^2\theta_0}{dt^2} + b \frac{d\theta_0}{dt} + \frac{1}{2} i_0^2 L n_r^2 \theta_0 &= \frac{1}{2} i_0^2 L n_r^2 \theta_i \\
 \frac{d^2\theta_0}{dt^2} + 2\zeta\omega_n \frac{d\theta_0}{dt} + \omega_n^2 \theta_0 &= \omega_n^2 \theta_i
 \end{aligned}$$

Frequency,

$$\omega_n = i_0 n_r \sqrt{\frac{L}{2J_m}}$$

Damping factor,

$$\zeta = \frac{b}{i_0 n_r \sqrt{2LJ_m}}$$

The corresponding system transfer function with output  $\theta_0$  and input  $\theta_i$

$$G = \frac{\theta_0(s)}{\theta_i(s)} = \frac{\omega_n^2}{s^2 + 2\zeta\omega_n s + \omega_n^2}$$

PID controller s domain transfer function

$$C(s) = K_p \left( 1 + \frac{1}{T_i s} + T_d s \right)$$

$f(t)$ - input time domain transfer function for stepper motor

$$f(t) = k_p \left[ e(t) + \frac{1}{T_i} \int_0^t e(t) dt + T_d \frac{d}{dt} e(t) \right]$$

$F(s)$ - input s domain transfer function for stepper motor

$$K_p + K_D s + \frac{K_I}{s} = \frac{K_p s + K_D s^2 + K_I}{s}$$

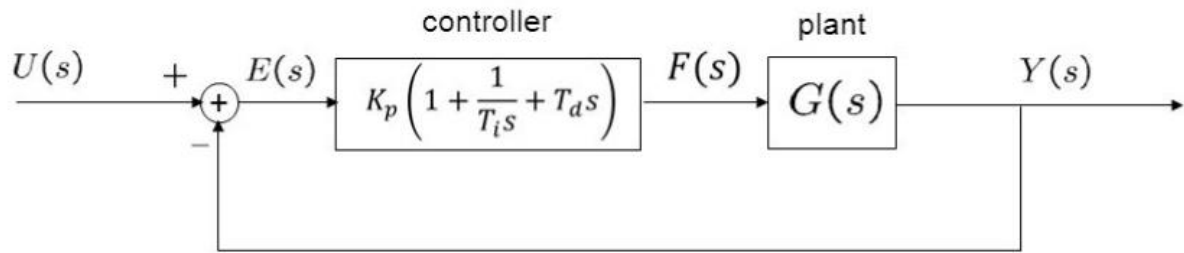

Figure 23: Closed loop feedback system [16]

Closed loop transfer function

$$G(s) = \frac{w_n^2}{s^2 + 2\zeta w_n s + w_n^2}$$

Following values have been taken from Nema 17 stepper motor data sheet

- $i_0$ - Constant stationary current = 1.5
- $n_r$ - umber of teeth in the rotor = 800
- L - Self- inductance of coil = 2.1mH
- $J_m$ - Polar mass movement of inertia = 0.038kgcm<sup>2</sup>
- b - Viscous damping coefficient = 0.8

$$w_n = i_0 n_r \sqrt{\frac{L}{2J_m}}$$

$$w_n = 1.5 \times 10^{-3} \times 800 \sqrt{\frac{2.1}{2 \times 0.038}}$$

$$w_n = 1.046 \text{ rad/sec}$$

$$\zeta = \frac{b}{i_0 n_r \sqrt{2LJ_m}}$$

$$\zeta = \frac{0.8}{1.5 \times 10^{-3} \times 800 \sqrt{2 \times 2.1 \times 0.038}}$$

$$\zeta = 1.67$$

Closed loop transfer function

$$G(s) = \frac{1.1}{s^2 + 3.4s + 1.21}$$

Following is the close loop system to represent the stepper motor without PID Controller

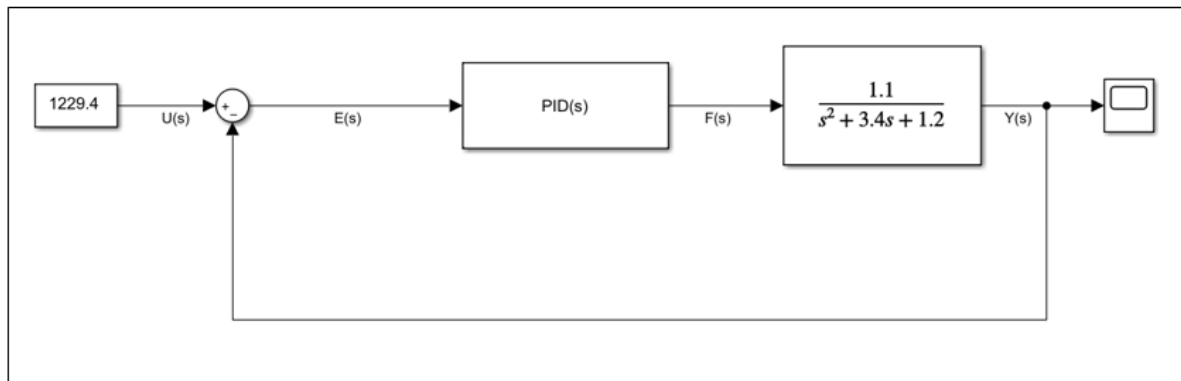

Figure 24: Control system

Output from the plant

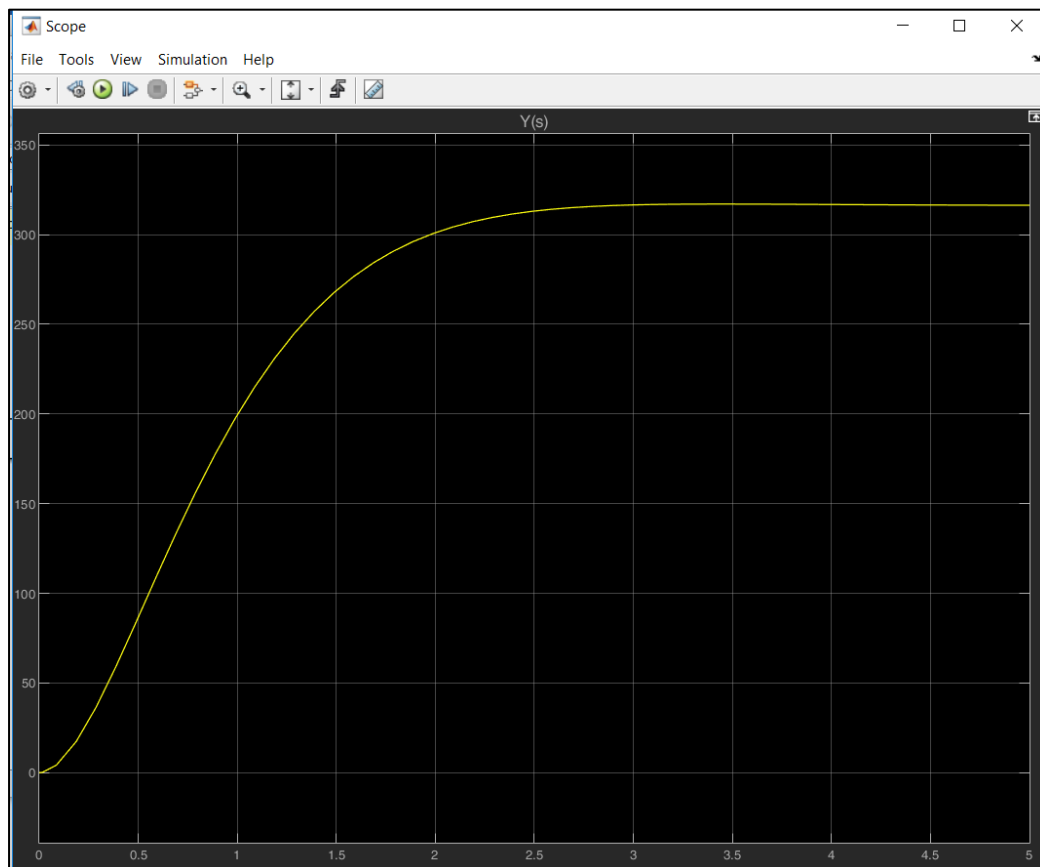

Figure 25: Step angle vs time

Following is the close loop system to represent the stepper motor with PID Controller

Here we use PID controller with stepper motor with feedback system

683 steps = 1cm

Steps angle in Nema 17 stepper motor =  $1.8^\circ$

So

$$1\text{cm} = 1229.4^\circ$$

Derive the closed-loop system in MATLAB Simulink



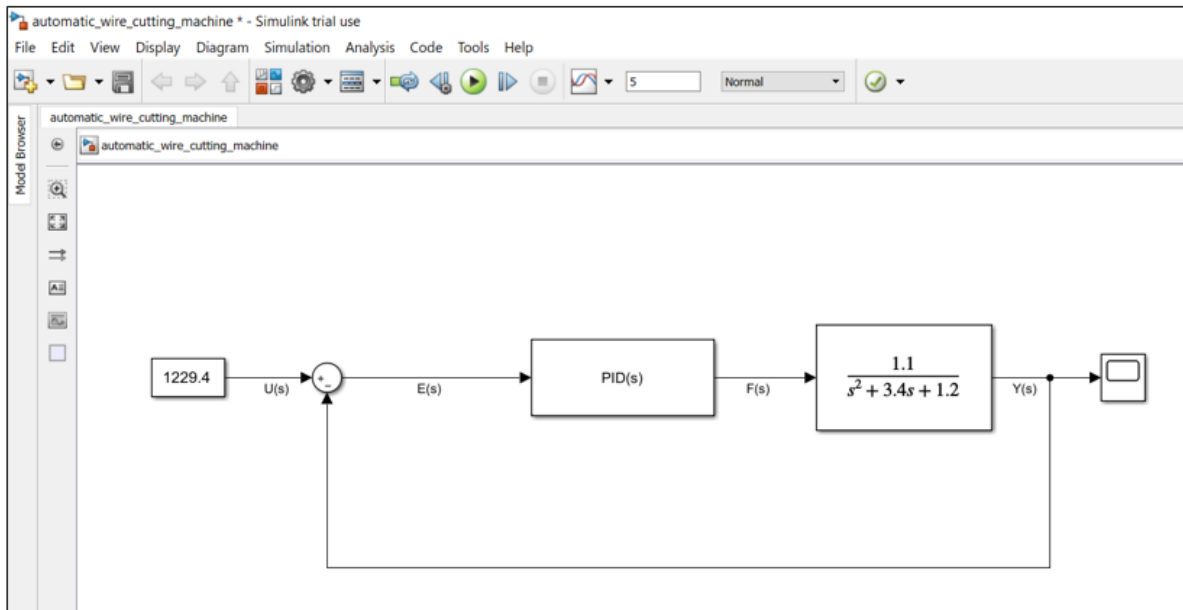

Figure 26: Closed loop system with PID controller

Output of the closed loop system

$K_p = 20$ ,  $K_i = 10$  and  $k_d = 0$

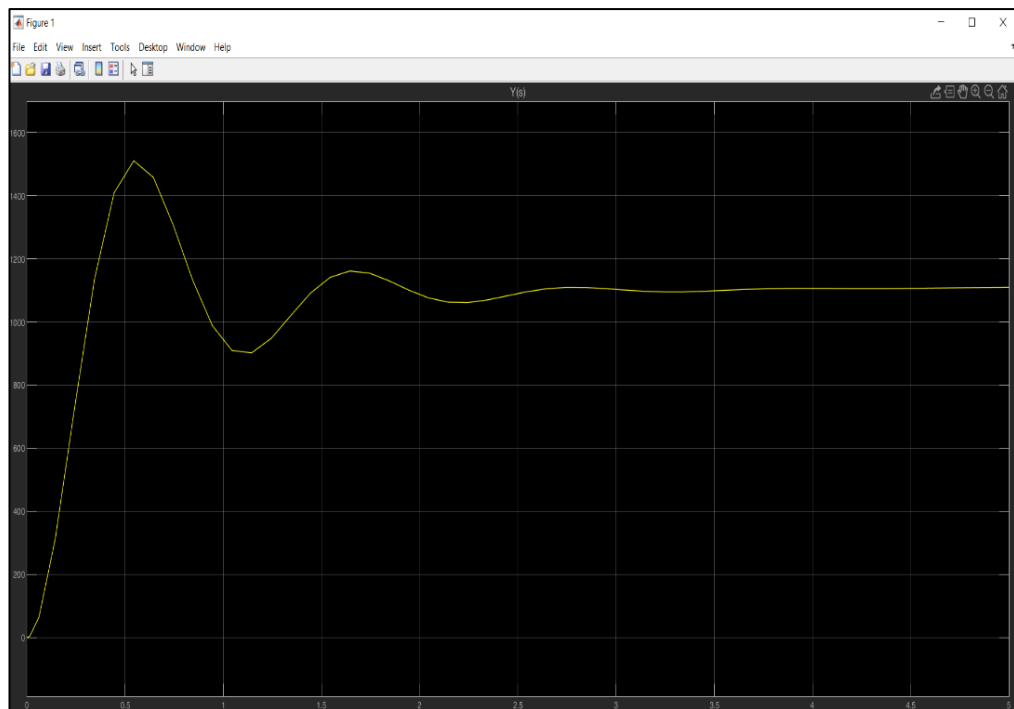
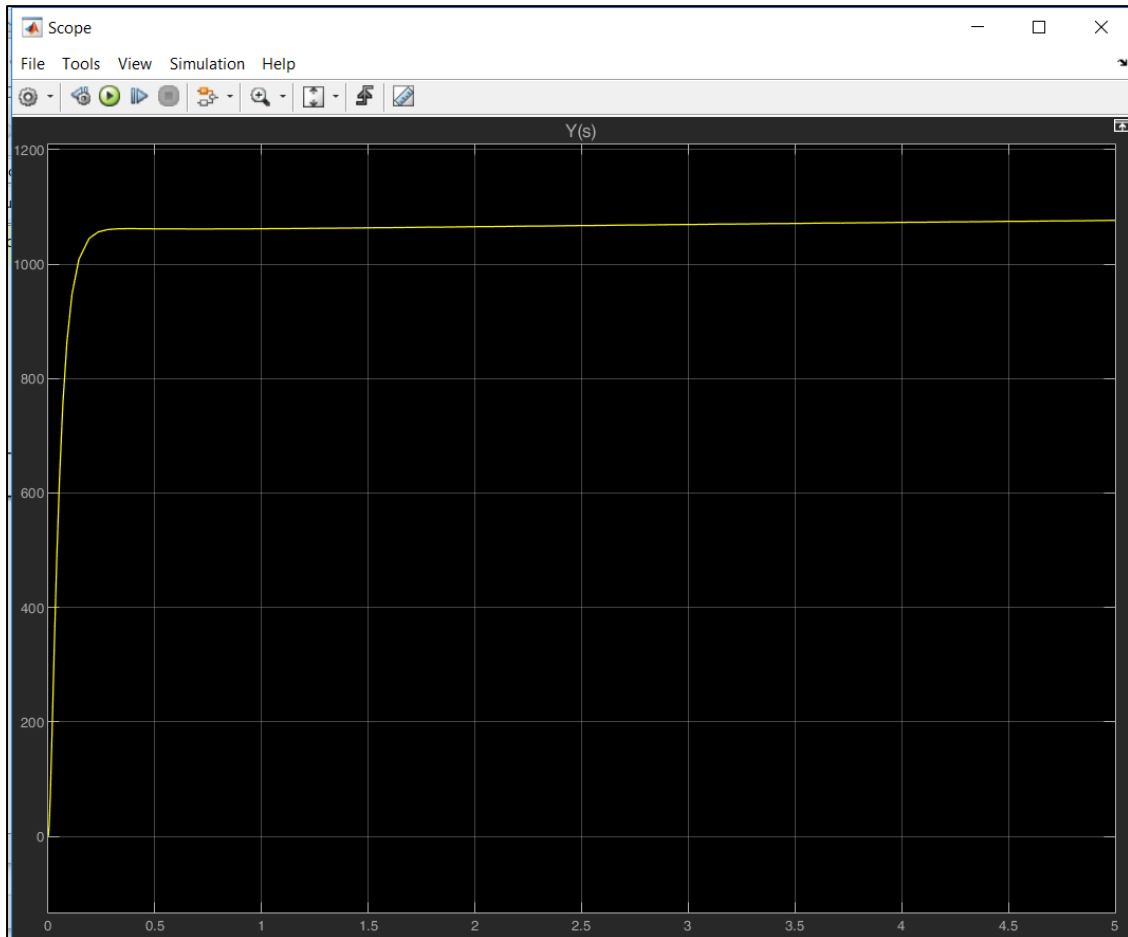

Figure 27: Step angle vs time

Here this output has 300° over shoot and 0.3 second rising time. Changing value of  $K_p$ ,  $K_i$  and  $K_d$  we can reduce the over shoot and smooth the system

PID controller  $K_p = 40$ ,  $K_i = 3$  and  $k_d = 15$



*Figure 28: Step angle vs time*

Here settling time is 0.2 second and system is fully smooth.

### 2.5.3 Plotting the Root Locus of a Transfer Function

The root locus is an extremely powerful tool for tuning controller parameters, the general configuration where this device is needed when we have a plant and the proposed controller with parameters  $k_1$ ,  $k_2$ , and want to determine which values we want to choose in order to perform these parameters. In here stable system means that all poles of the closed loop system are on the left side, so that we need to see how each of your control parameters affects the pole that's where the root locus is useful because it shows us where the pole matches all value of your controller parameters are located and of course, we are still limited by physical constraints that prevent our parameters from having large values or very small, but the root locus can also predict system behavior beyond these limitations which may not be so useful or migrate. Another criterion for pole positioning is the amount of damping and response speed, the root locus is very useful in these situations and if the optimal parameter configuration for the controller is in place, we can look at other aspects of the behavior that may not precisely be defined by the root locus

Open loop transfer function

$$G(s) = \frac{1.1}{s^2 + 3.4s + 1.2}$$

Design a root locus closed-loop control system.

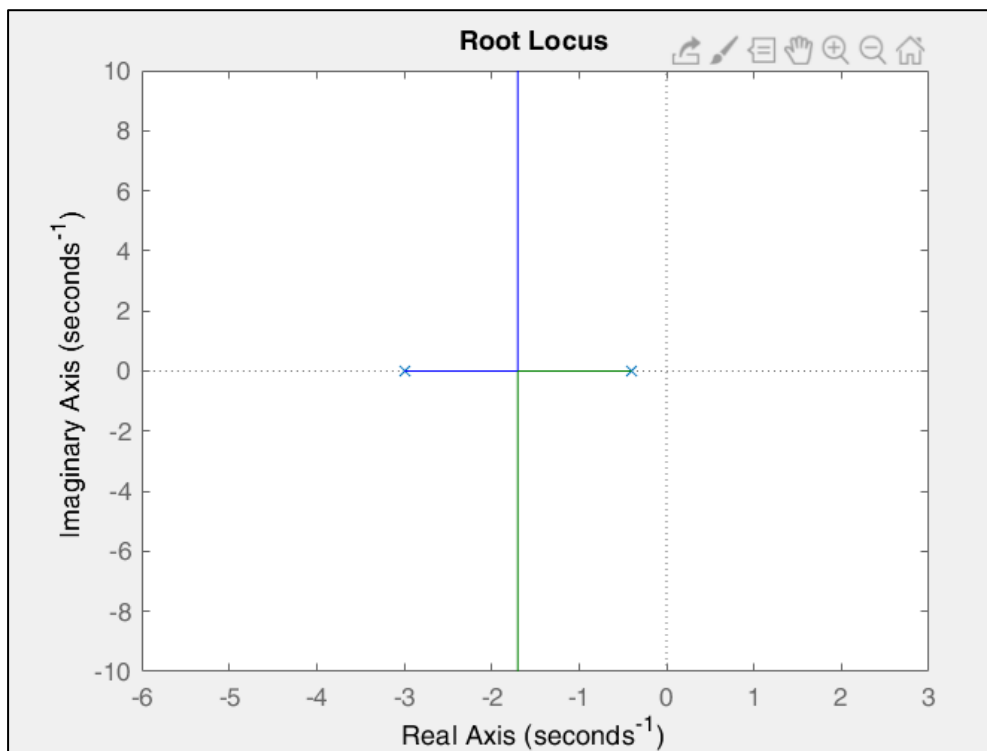

Figure 29: Root locus output

For analysis and design, the control system design function can be used. In this scenario, the root locus will be used as a design method to enhance the closed loop system step response. The plot above shows every possible pole position for a pure proportional controller. In this scenario, our design requirements are not met at all these closed-loop pole locations. We can use the sgrid (zeta,wn) command to draw lines of constant damping and natural frequency to determine which part of the locus is acceptable. The damping ratio  $\zeta$  and natural frequency  $w_n$  are the main two arguments (These could be vectors if a range of acceptable values are to be examined). In our case, we need an overall surplus of less than 5% (that is to say, a damping ratio  $\zeta$  greater than 1.67)

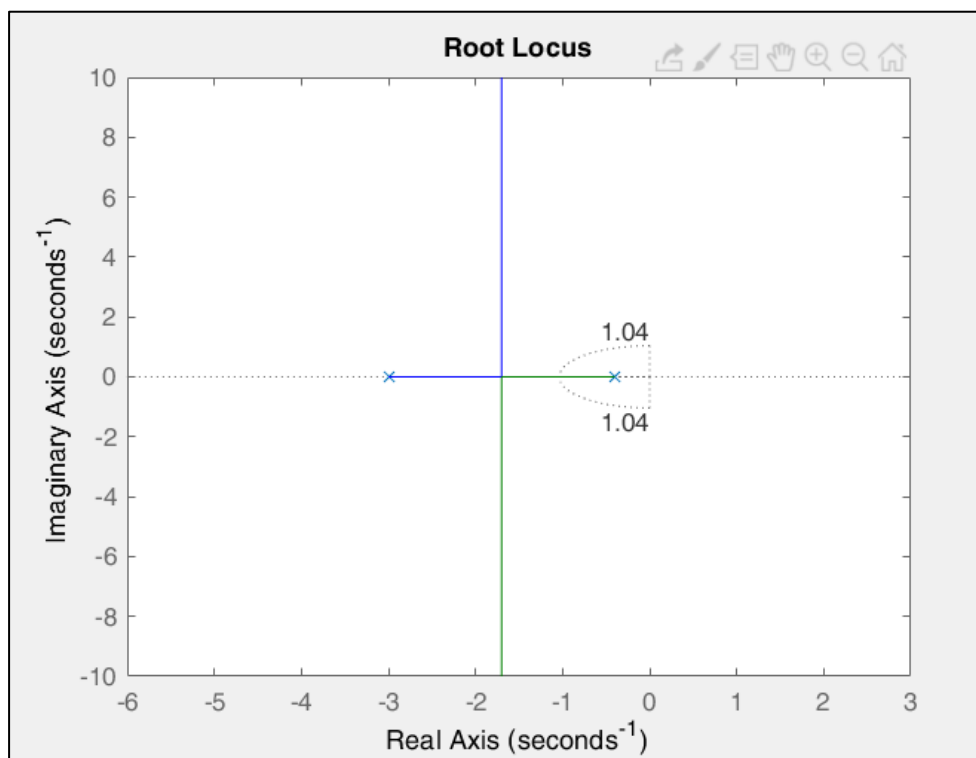

Figure 30: Root locus output

The two dotted lines at an angle of around 45 degrees show pole positions on the figure 32 above with  $\zeta = 1.67$ ; The poles shall have  $\zeta > 1.67$  in between those lines, and  $\zeta < 1.67$  outside those lines. The semi-circle shows the pole position with a natural frequency  $w_n = 1.04$ ;  $w_n < 1.04$  within the circle; and  $w_n > 1.04$  outside the circle.

Moving to our problem, the poles must be within the two angled dotted lines, to reduce the time of ascent to less than one second, the poles must be outside the dotted semi-circle. Now we have the idea which part of the root locus is fulfilling the requirements, which are possible closed-loop sites. All poles are at this point in the left half plane, so that the system of a closed loop is stable.

We can see from the plot above that the desired region contains part of the root locus. Moreover, we only require a proportional controller in this case to transfer the poles to the desired area. We can select the desired poles in the locus with the 'rlocfind' function in MATLAB.

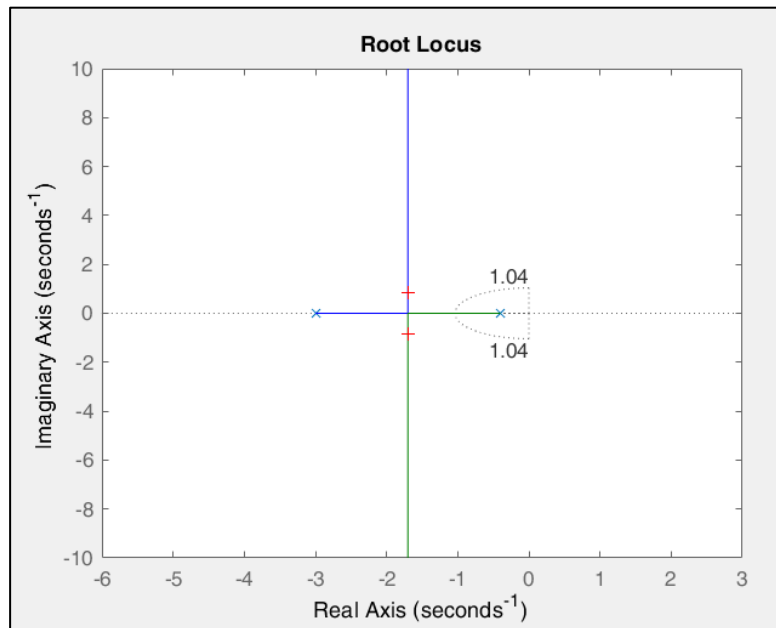

Figure 31: Root locus output value  $K$

Since there may be more than one branch on the root locus, if we choose a pole, we can also identify other closed loop poles, all of them at the same value of  $K$ . Note that the reaction will also affect these poles.

The plot above shows that the two closest ones to the imaginary axis are in our desired region of the four selected poles which is indicated by "+" signs. As these poles tend to dominate the answer, there is some trust that a proportional controller with this  $K$  value is satisfied with the desired requirements. We need to know the closing loop transfer function to verify the step response.

The two arguments for the feedback function are the forward path transfer function and the forward loop feedback function. In this scenario, the system is unity feedback.

Checking the closed loop system step response with the value of  $K$  selected:

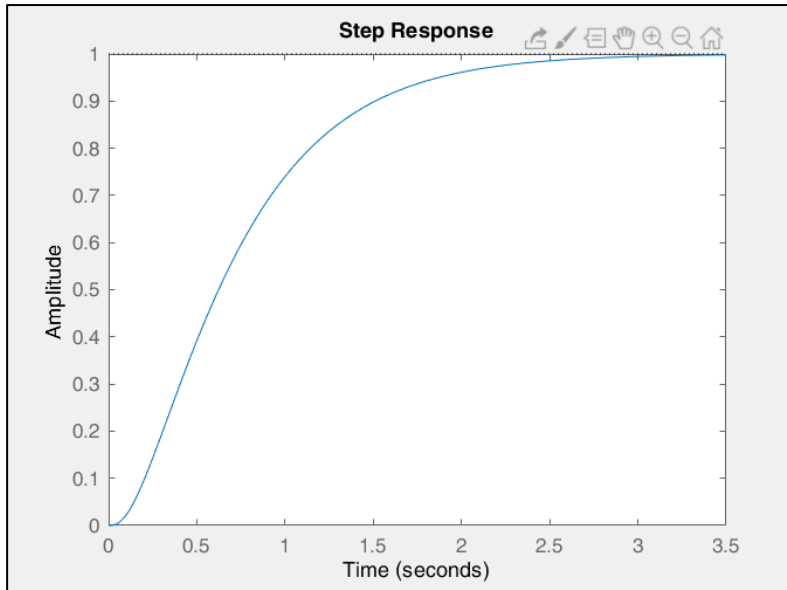

Figure 32: Step response

This response is expected to outweigh less than 5% and to increase time less than 1 second.

### Control System Designer for Root Locus Design

First, we design the transfer function  $G(s)$

For analysis and design the control system design function can be used. In this scenario, we will focus on the root locus as the method of design to improve the closed loop system's progress response. To start, in the MATLAB command window, type the following:

We should then see the following window. We may also start our GUI using the APPS tab and click the Control System Design and Analysis application icon. We can observe the root locus plot, the open-loop Bode plot for the given plant and the closed loop response plot in unit feedback.

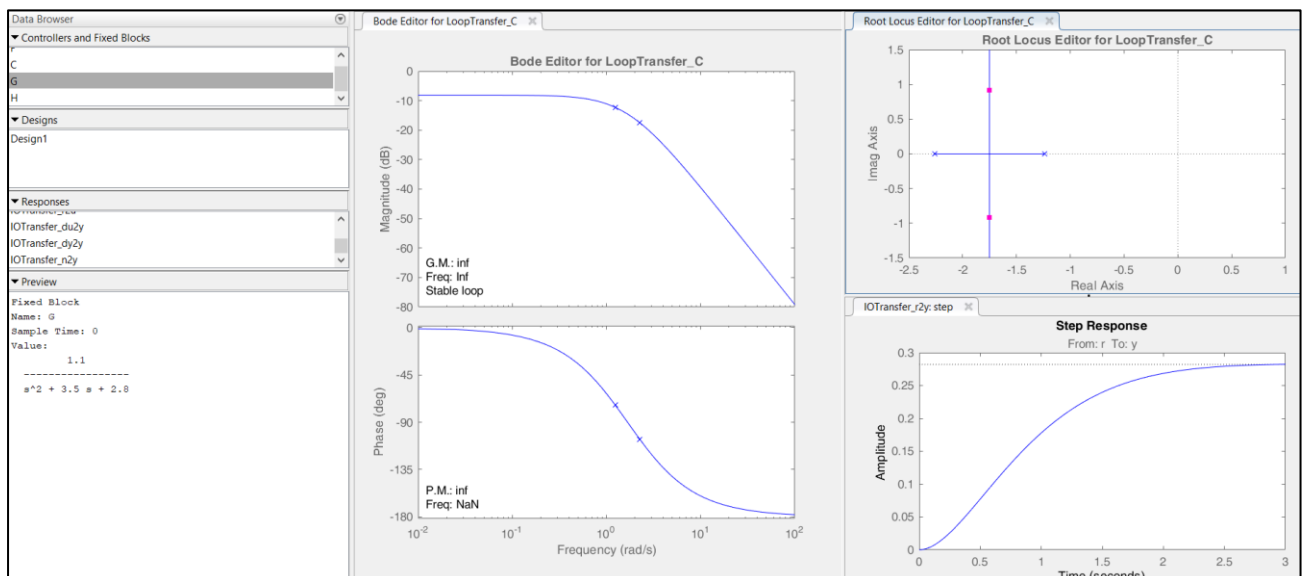

Figure 33: Control system designer output

Here, as previously done with sgrid, we will set the design requirements for damping and the natural frequency. Recall  $\zeta = 1.67$  and  $\omega_n = 1.04$  call for the boundaries of the requirements. Any white area on the plot is an acceptable area for the locked pole.

### 2.5.4 Sensitivity analysis of automatic wire cutting and striping machine

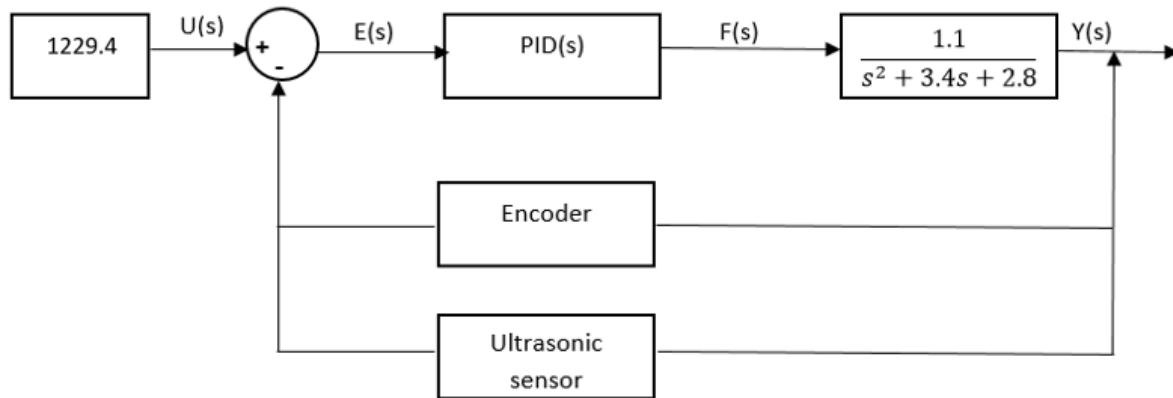

Figure 34: Closed loop encoder feedback system

Stepper Motor transfer function

$$G(s) = \frac{1.1}{s^2 + 3.4s + 1.2}$$

Stepper motor speed control means that we have a  $1/s$  term that comes from the position derivative.

$$s \times G(s) = \text{Speed of motor}$$

So

$$G(s) = \frac{k \times 1.1}{s \times (s^2 + 3.4s + 2.8)}$$

The above transfer function is calculated by using encoder and position sensors, but These parameters are in some cases linked directly to the step engine. So, our P-I-D controller parameters have been decided using the step motor transfer function directly.

Including P-I-D and square wave generators, the ultrasonic sensor is also directly connected with Arduino's Microcontroller. Therefore, the transmission function of the ultrasonic distance sensor has not been calculated. We have used 4 CNY70 sensors for the position sensors. Both CNY70 and Schmidt triggers are included in the position sensors. Schmidt triggers are used to achieve either 0 or 5 volts with CNY70 sensor output. When the sensor sees black line, the sensor output is HIGH (5V), and the sensor is LOW (0V), if white area is visible. We found that the average and total output of the sensors can find the exact position and the error. The error shows that the power of the motors changes to keep us on the black line.

We can regulate the wire cutting machine automatically at higher speed using PID. In particular, PID is a great advantage. A sequence that simulates two different positions (in this instance 90 degrees) as a position is then compared to the output of the position sensor (encoder) which is the position of the step motor. PID controller transmit the error correction to the stepper motor. The encoders are split into absolute encoder and incremental. The ROTARY-type incremental Photoelectric Encoder is selected for supply voltage from 5 to 24V DC, maximum reaction frequency from 100 kHz. The photo code is separated into the grid 1024 using A, B, top and bottom of the two channels. TTL voltage output is the output.

### 2.5.5 Stepper motor Torque Vs Speed analysis and calculation

This kind of modified stepper motor usually has a 1.8- and 0.9-degree step angle and various 40 mm to 100 mm lengths. Figure 40 illustrates the performance of this engine type. A motor has been selected with a 5-degree, 2.8 - ohm bipolar winding and 42 mm long. This is the smallest engine in this class. The step angle of 5 degrees is interesting when the shaft is higher than the holding torque. The diagram shows that the motor is 42 mm highly efficient but is 4 times higher. In the range from 3000 to 3500 Hz, the maximum output is over 30W. The motor power loss at high speeds is around 12W (including driver 16W). This is acceptable when the engine is cool, and the operating cycle is 100 percent. The losses drop at low step rates and losses stand at only 3W. This illustrates that the engine current can be increased to even higher torque and power at low levels. The reduction of low frequency torque can reduce noise levels and vibrations in applications in which the friction torque uses more than the load inertia of the motor torque. The engine is ideal for paper handling and transport in high-performance printers and plotters.

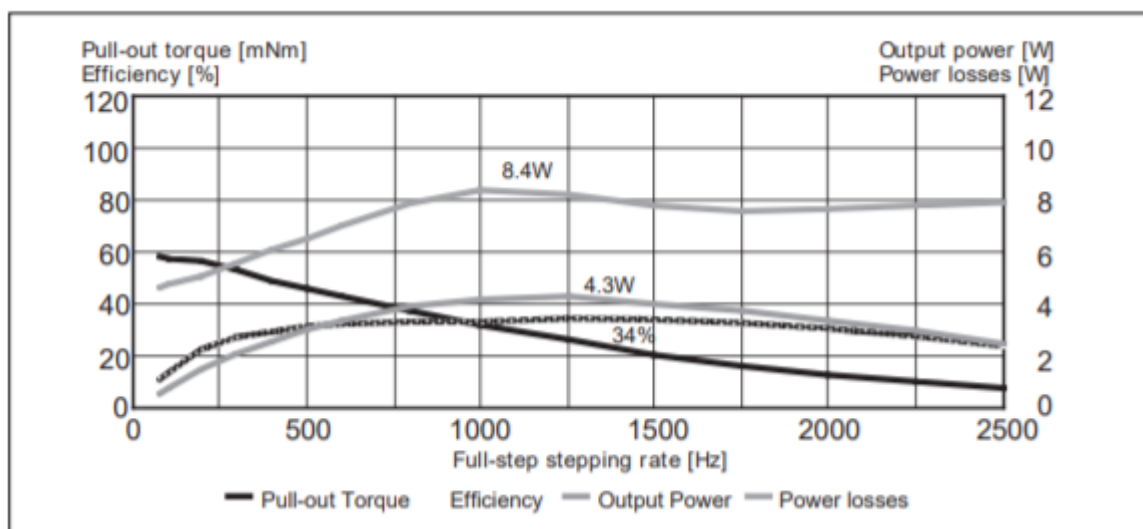

Figure 35: Performance curve of nema 17 stepper motor [17]



A good design requirement for a winding design is the EMF of the winding process. Optimal motor efficiency and output are reached near the step frequency where the maximum EMF value is equal to the driving voltage. For example, with a 40-volt chopping voltage, this provides a maximum stepping rate of 2kHz. At 2kHz we see that efficiency as well as power output reach their maximum values. A 10mV / Hz EMF constant winding should be used to design a 20 Volt winding with maximum output at the same step rate. This winding has half the number of turns and therefore 1/4 of the original roll strength and inductance. The winding current is twice the original value to achieve the same holding torque and low frequency performance. The optimum step rate cannot be increased to very high values for an motor due to hysterical loss and rotor leakage induction decrease efficiency. The EMF of an engine will be measured through a continuous speed rotation by connecting the motor winding to an oscilloscope and measuring the maximum value and signal frequency. The frequency generated corresponds to an overall rate of four-time higher. This is used to calculate the EMF. On this figure 40, the optimal frequency of operation can be found in the reduction of cuts voltage from 40 to 30 volts, from about 2 kHz to 1.5 kHz.

The following graph indicates that how wire cutting accuracy changes against speed.

Speed (rpm)	Torque (N-m)	Power(N-m/s)
104	0.576	0.23
108	0.552	0.44
111	0.528	0.63
115	0.504	0.8
119	0.48	0.96
123	0.456	1.09
127	0.432	1.2
130	0.408	1.3
134	0.384	1.38
138	0.36	1.43
142	0.336	1.47
146	0.312	1.49
149	0.288	1.49
153	0.264	1.47
157	0.24	1.43
161	0.216	1.38
165	0.192	1.3
168	0.168	1.2
172	0.144	1.09
176	0.12	0.96
180	0.096	0.8
184	0.072	0.63
187	0.048	0.44
191	0.024	0.23
195	0	0

Table 3: Speed vs torque

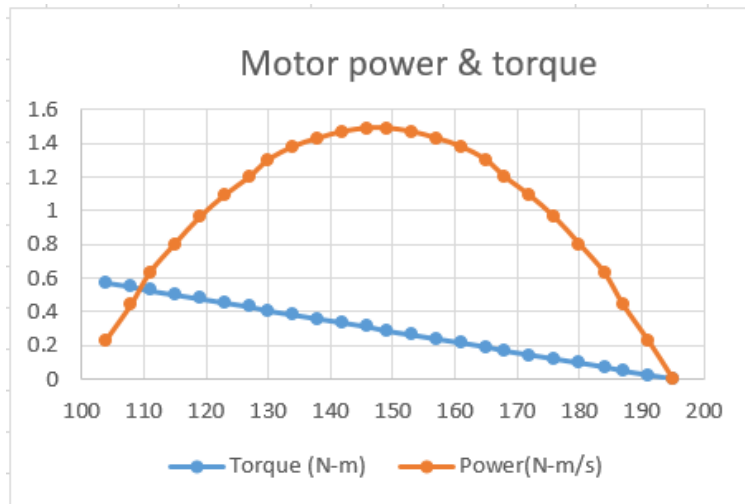

Figure 36: Motor power vs speed

The following table explains the number of steps per cm of output wire length

Steps	Distance cm
5000	7.32
5300	7.75
5400	7.9
5600	8.2
5800	8.5
6000	8.78
6200	9.07
6400	9.37
6600	9.66
6700	9.8
6750	9.88
6770	9.91
6780	9.92
6800	9.95
6810	9.97
6820	9.98
6830	10
6840	10.01
6850	10.02
6860	10.04
6880	10.07
6900	10.1

Table 4: Steps vs distance

200 steps = 1 rotation  
 Stepper Motor has 1.8-degree step angle  
 6830 steps = 10cm  
 So, 683 steps = 1cm

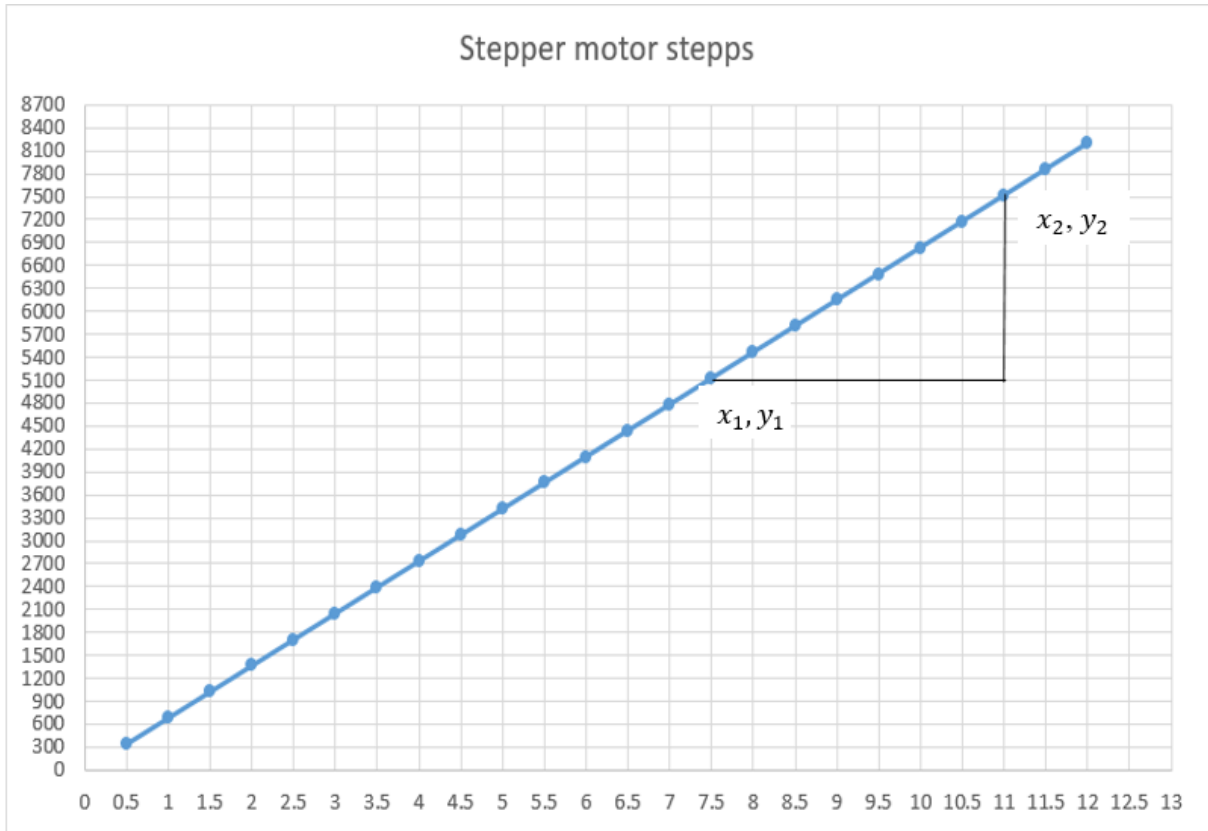

Figure 37: Stepper motor steps vs length calculation

$$m = \frac{y_2 - y_1}{x_2 - x_1}$$

$$m = \frac{7513 - 5122.5}{11 - 7.5}$$

$$m = 683$$

So from this graph

$$1\text{cm} = 683\text{steps}$$

Stepper motor will rotate 683 steps per 1 cm wire

## 2.6 Component Analysis for the Proposed System

### 2.6.1 Arduino Uno board

In this investigation, I chose Arduino, the main advantage of Arduino is that its framework is fully prepared to be used. The full container form of Arduino provides a 5V regulator, micro controller and interface for serial communications [7]. We do not need to consider programming links or any other interface. We need to Just connect it to our computer's USB port and then set of programming code would make things happen.

### 2.6.2 12 DC wiper Motor

I chose a 12 v DC wiper engine to manage the cutter, because the engine is 13.5-pound feet of full speed, and 17.5-pound feet torque of low speed. Thus, we can efficiently and quickly cut the wire [6].

Type	No-Load Speed	Rated			Peak Torque N.m	L1 mm	L2 mm
		Speed rpm	Current A	Torque N.m			
WD1160	40	28	5.6	5.2	8.5	182	225
	31	24	4.8	7	10		
WD1160-B	40.5	28	5.8	6.5	10	199	235
	27	21.5	6.3	13.2	15		

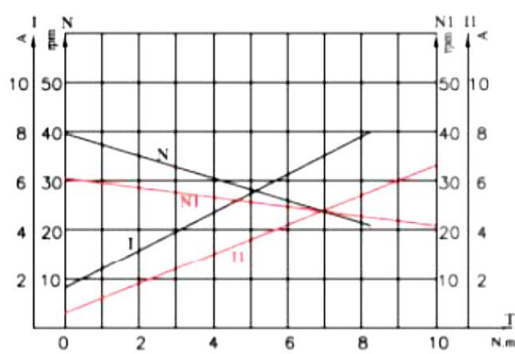

WD1160

---BLK High Speed.

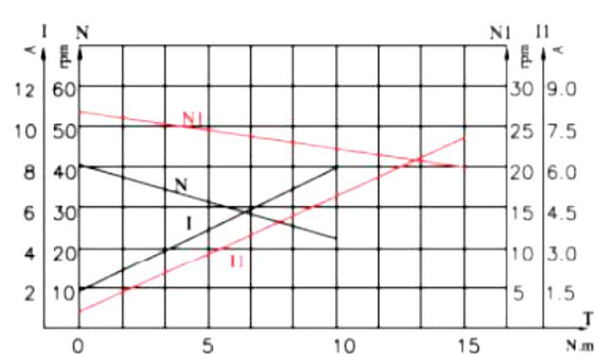

WD1160-B

---RED Low Speed

Figure 38: Wiper motor specification [15]

### 2.6.3 Dc Motor Driver

The module L298N H have been used on motors with a voltage of between 5 and 35 V DC and I used L298 motor control because it is capable of controlling the velocity of the engine. There's also a 5 V controller, so that we can supply up to 12 V with 5 V of the board

### 2.6.4 Stepper motor

I've chosen NEMA 17 stepper as the maximum of 900 rpm, the maximum torque is 0.11 nm and the maximum torque can be 1.8 degrees per step [8]. When we use the NEMA 17 to measure the cable length, we get an accurate length as 200 steps for one rotation.

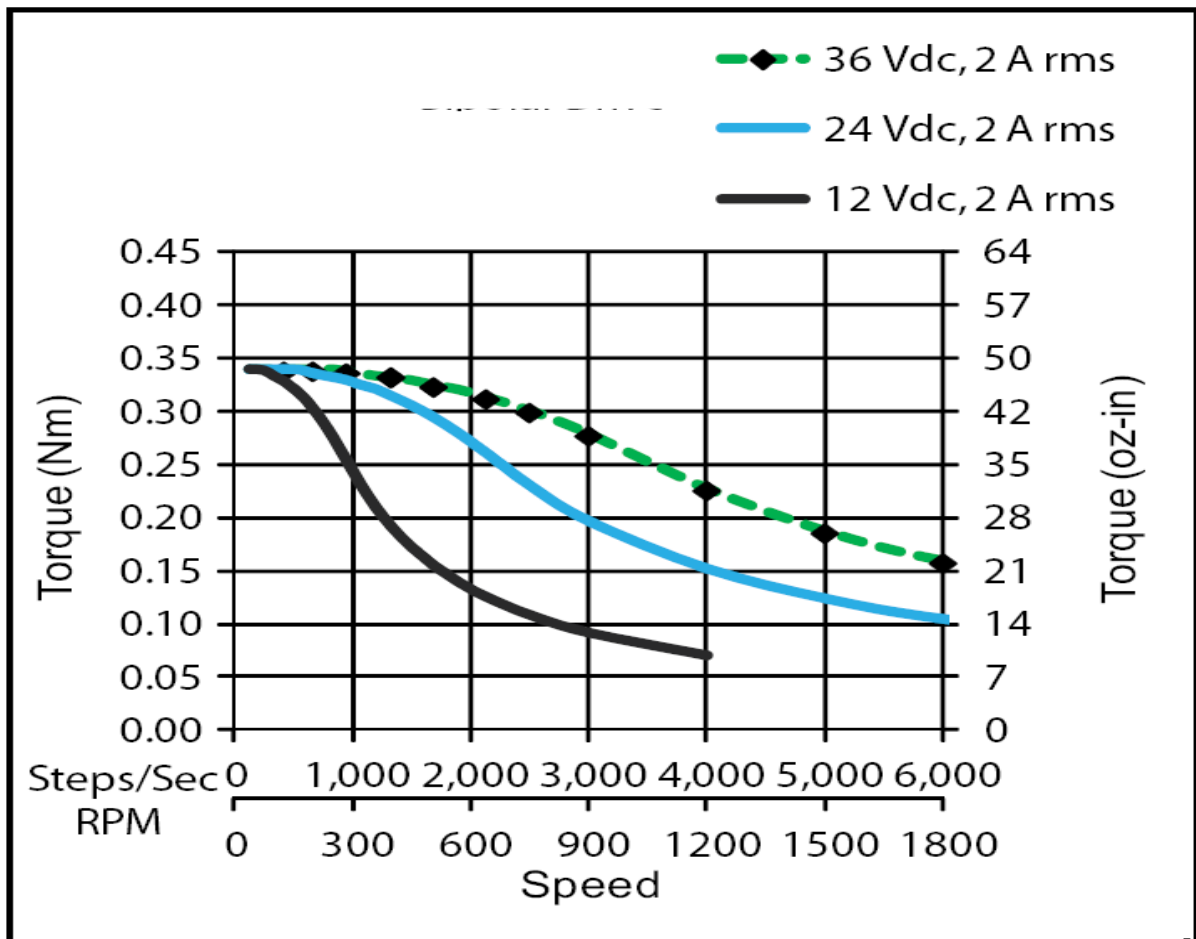

Figure 39: stepper motor nema17 [16]

## 2.6.5 Stepper motor driver

The Easy Driver V4.5 is used in this stepper engine project because the driver can operate up to 750 meters by stage of a bi - polar stepper engine. It's 8 steps micro step by default. So if the engine is 200 steps per revolution, the Easy Driver will give you 1600 steps / rev. It is a micro step driver with chopper based on the chip driver Allegro A3967.

## 2.6.6 Step down converter

In order to convert the fixed output voltage to 3.3 V, 5 V and 12 V, I have selected a buck converter for the project. The input can be between +4 and 40 V.

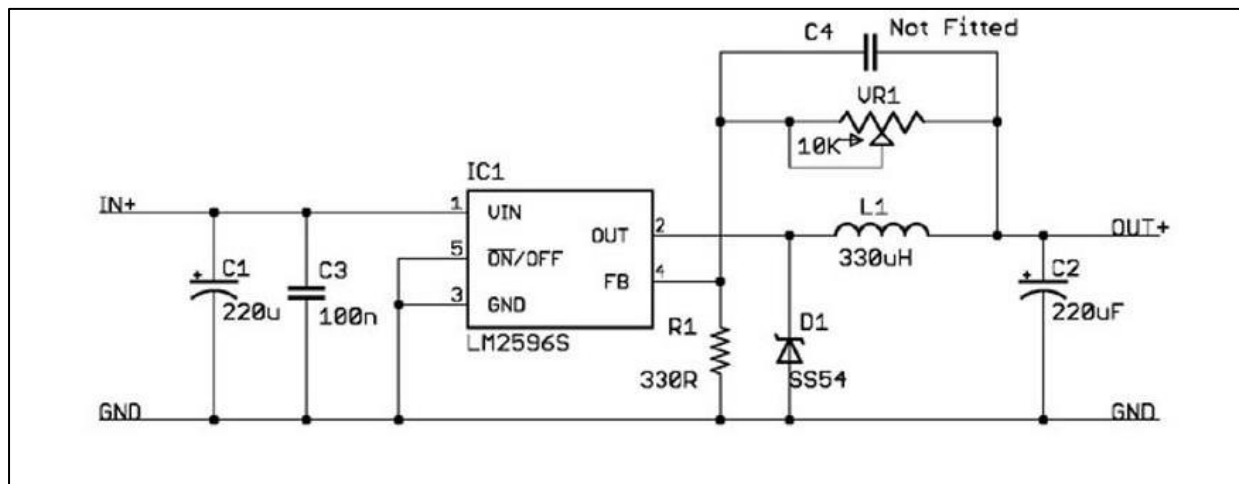

Figure 40: LM296 circuit diagram [17]

## 2.6.7 Servo Motor

I have used a servo motor here to choose half - cut and complete - cut. The DC engine is fast and has a low torque, however the gearbox decreases speed by 60 RPM and rises torque at the very same moment. The signal frequency should be 50 Hz or every 20 ms a pulse should happen. The pulse width defines the angular status of the servo, which can rotate 180 degrees in this kind of servo.

## CHAPTER 3: EXPERIMENTAL RESULTS AND DISCUSSION

The results of the developed system and the comparison are presented in this chapter. The cost analysis of different industries will also be discussed in 3.2. The dissertation highlighted some of the restrictions in the automated system developed.

### 3.1 Output and Results

No	Required feet	No of wire	Human Error	Error in the wire cutting
1	3	40	10	2
2	2	20	8	1
3	5	30	12	3
4	2	60	15	4
5	3	40	12	2
6	1.5	120	22	5
7	2	100	16	4
8	3.5	90	18	4
9	2.7	70	9	5
10	1.6	150	25	7
		720	147	37
<b>Error percentage</b>			<b>20.14%</b>	<b>5.13%</b>

Table 5: Required feet vs error

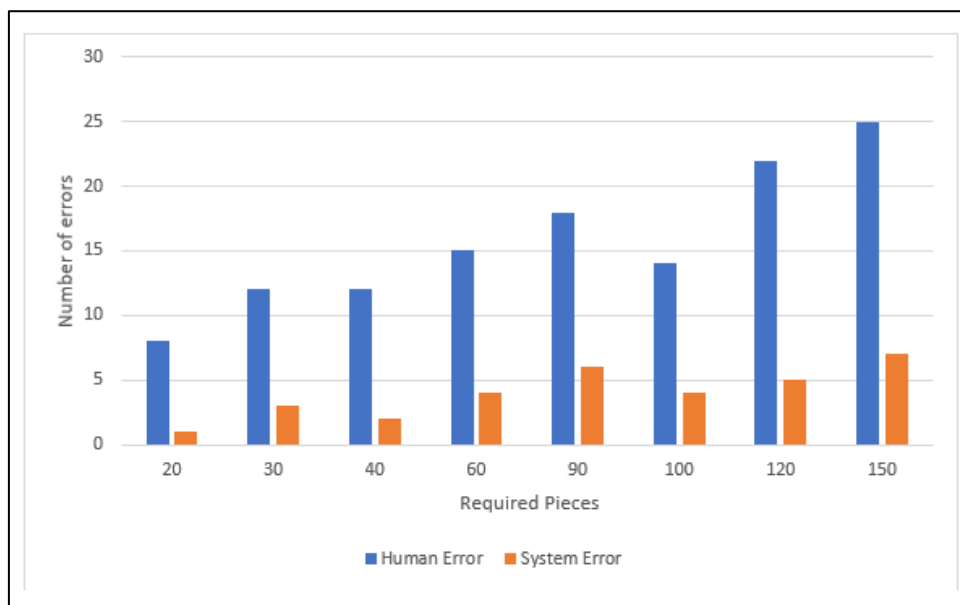

Figure 41: Required feet vs error

Here, approximately 5 to 35 mm has been considered as the error in automatic wire cutting

### 3.1.1 Analysis between speed and Accuracy of the System

Speed (rpm)	number of 5cm pices in 10min tin	number of error >0.5cr
40	23	0
50	29	0
75	43	0
100	58	0
125	73	0
150	87	0
175	102	0
180	105	0
185	108	1
187	110	2
195	114	4
200	117	6
250	146	10
300	175	20
350	204	35
400	234	60
450	263	82
500	292	110
550	322	140
600	351	180

Table 6: Speed vs error

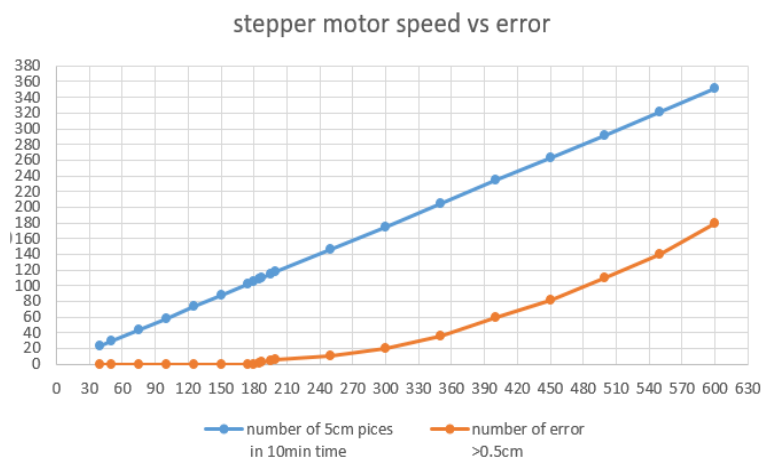

Figure 42: Speed vs error

The above *Figure 42* showcases the graph between the speed of the system and the error distance. As graph indicates, system's speed can be changed between 40-600 RPM. Since up to 0.5cm of error is being acceptable in the industrial market, 187rpm speed is recommended for this system.

### 3.2 Cost Analysis

According to small scale industry, mostly 5cm or 10cm length of pieces are required for projects. Following table, no:6 analyses the number of human hours to cut and strip the 5cm length of pieces. Also, calculation has been done for the same amount of work via automated wire cutting machine. Based on the comparison, we could come up with the conclusion that automated wire cutting machine spend only 167 hours to cut the certain amount of wires whereas manually labours have to spend 418 hours.



No of Projects	No of hours
1	95
2	12
3	42
4	9
5	58
6	15
7	64
8	87
9	18
10	18
<b>Total</b>	<b>418</b>

Table 7: Number of projects vs number of hours

### Cost calculation for manual wire cutting and striping process

1-hour labour charge = Rs 200.00

For this panel we need 418 labour hours

So, Total labour charge for this panel =  $200 \times 418$

$$= \text{Rs } 83600.00$$

418 labour hours is required to cut and strip 100320 pieces of wire

So 1 labour hour is required to cut and strip 240 pieces

So 1 minutes = 4 pieces

Cost for wire wastage and Re-correction charges = Rs 15,000.00

Total Cost for this process = Rs 98,600.00

### Using automatic wire cutting machine (open loop system)

Within 1min time 5 cm wire length of 10pieces of wire we can cut and strip.

Stepper motor has 200 steps per revolution

1cm = 683 steps

For 1min stepper motor rotate =  $5 \times 683 \times 10 = 34150$  steps

So stepper motor speed =  $34150/200 = 170$  rpm

The developed Automated wire cutting machine's price = Rs 15,400.00

Electricity usage charges = Rs 10000.00

Labour charge for supervision =  $\text{Rs } 1000.00 \times 40 = \text{Rs } 40000.00$

Within 1 min we can cut 10 pieces

100320 pieces we need =  $100320/10=10032$  min

Using this automatic wire cutting machine we finished this within 167 hours' time

Total Cost of this process =  $10000.00 + 40000.00 = \text{Rs } 50000.00$

### Using automatic wire cutting machine (closed loop system)

we can achieve 600 rpm

stepper motor has 200 steps per revolution

so within 1 min we can cut and strip the wire =  $600 * 200 / (683 * 5) = 35$  pieces

100320 pieces we need =  $100320 / 35 = 2867$  min

Using this automatic wire cutting machine we finished this within 48 hours' time

Following table analyses the number of minutes spend via automated wire cutting machine and manual approach for cutting between one to five feet wires. According to our analysis automated process required considerable amount of hours to complete the task compared to manual approach but error percentage of wire cutting is significantly lower than manual approach and most import key is that automated approach doesn't require labour efforts.

No	Required length (feet)	Required length (cm)	No of wire	Human Error (#no)	Working Time (min)	Developed System error (#no)	System working time (min)
1	3	91.44	40	10	10	2	26
2	2	60.96	20	8	5	1	8
3	5	152.4	30	12	7.5	3	32
4	2	60.96	60	15	15	4	26
5	3	91.44	40	12	10	2	26
6	1.5	45.72	120	22	30	5	39
7	2	60.96	100	16	25	4	43
8	3.5	106.68	90	18	22.5	4	68
9	2.7	82.296	70	9	17.5	5	41
10	1.6	48.768	150	25	37.5	7	52
<b>Total</b>			<b>720</b>	<b>147</b>	<b>180</b>	<b>37</b>	<b>361</b>

Table 8: Required feet vs working hours

### Cost analysis for the developed wire cutting and striping machine

No	Description	Cost(Rs)
01	Arduino board	1,500.00
02	Stepper motor	3,500.00
03	Servo motor	900.00
04	Wire cutter	700.00
05	Wiper motor	3,800.00
06	Other materiel charges	5,000.00
	<b>Total charges</b>	<b>15,400.00</b>

Table 9: Cost analysis for wire cutting machine

#### 3.2.1 Cost comparison between small-scale industrial machines, large scale industry machines and the developed automated wire cutting machine

Large scale industry machine price LKR = Rs 1,497,403.18

small scale industry machine price LKR = Rs 709,800.00

The developed Automated wire cutting machine's price LKR = Rs 15,400.00

#### 3.2.2 Productivity comparison between small scale industry and the Developed Automated wire cutting machine.

No	Description	Small scale industry	Developed Automated wire cutting machine
1	Model	HRG-2830-2c	WCM
2	Power supply	220V 50/60HZ	220V 50/60HZ
3	Cutting length	0.1- 60000mm	1-1000cm
4	Striping length	0.1-180mm	1cm
5	wire striping range	0.1-35mm <sup>2</sup>	0.3mm <sup>2</sup>
6	Speed	2000-8000pcs/h	1500-4000pcs/h
7	Wire pressure regulation	yes	yes
8	Display	LCD display	LCD display
9	Size	450*380*350mm	500*400*700
10	Weight	50kg	18kg

Table 10: Small scale machine vs Large scale machine

### 3.3 Limitations

In a specific organization, the proposed method is evaluated primarily. A precise heuristic system requires long - term analysis of the data, possibly few more years. Data are not collected for several years in this research. Due to the friction and the torque of the feeding pulley that can affect the precision of the cutting process and high speed is not considered for the automated wire system.

## **CHAPTER 4: CONCLUSION AND FUTURE WORK**

The dissertation ends the discussion based on the findings in Section 4.1 and on the future improvements to the system proposed in Section 4.2.

### **4.1 Conclusion**

Auto Wire Cutting Mechanism offers high degree of accuracy and approximate cutting of wires compared to the current industry cutting process. The exact amount of wires with the desired length is given by this mechanism. This system reduces the complexity of the circuit. Since the complexity is diminished in the circuit, it is easy to grasp and as a result, production efficiency is drastically increased.

As mentioned in Chapter 3, this system has as its main benefit economic efficiency and accuracy. In very little time, the desired result will also be obtained. Compared to manual cutting process, the time required to cut the wires is less. It's helpful for the workers because of its simple hardware. The current small industry's wire cutting machine, as mentioned in the previous chapter, cannot even be considered because of price constraints, but the costs of the developed project are fairly very small. It is therefore affordable and implemented successfully in the small-scale industry.

### **4.2 Future Scope**

This mechanism can be developed with the help of GPS and GSM for the automatic wireless system. This is going to have a big effect on electrical industry and the Android app can be developed to operate from mobile or cell phones. These are the future elements in this particular area of the project development

## REFERENCES

- [1] M. Ioannides, Design and implementation of PLC-based monitoring control system for induction Motor, *IEEE Transaction on Energy Conversion*, vol.19, no.3, pp.469 - 476(2004).
- [2] H. Harris and N. C. Durham, "Wire striping machine," United State Patent 2,880,635, April 7, 1992.
- [3] C. Lucien and C. Ducret. "Automatic cable measuring and cutting machine ", <https://patentimages.storage.googleapis.com/4b/19/ce/65429533962ad9/US4476754.pdf>, 2017.
- [4] D. W. Russell, "Application of PLC's as front-end pre-processors in factory information systems", *The International Journal of Advanced Manufacturing Technology*, vol.6, no. 4, pp. 364-377, Sep 5, 1999.
- [5] D. O. Carrica, S. A. González and M. Benedetti, A high speed velocity control algorithm of multiple stepper motors, *Mechatronics*, vol.14, no.6, pp. 675-684, July 5, 2004.
- [6] O. T Sawant, S Patil. "Development and Designing of Automatic Wire Cutting System using Microcontroller". *International Journal of Advanced Research in Electrical, Electronics and Instrumentation Engineering*, Vol. 6, June 6, 2017.
- [7] Ms. Poonam Mane, Ms. Shalaka Mali. "Automatic wire cutting machine". *International Research Journal of Engineering and Technology (IRJET)*, Vol 4, Feb 02, 2017.
- [8] Kunshan. "Pfl-02 Led Factory Used Electric Automatic Cable Wire Stripping Machine ". [online]: [https://www.alibaba.com/product-detail/PFL-02-LED-Factory-Used-Electric\\_62125215025.html?spm=a2700.7735675.normalList.1.kC34gX](https://www.alibaba.com/product-detail/PFL-02-LED-Factory-Used-Electric_62125215025.html?spm=a2700.7735675.normalList.1.kC34gX),2017.
- [9] P. Cleaveland, Programmable Controllers Adapt to New Industry Needs, *Control Solutions*, vol.4, no.1, pp. 47-50(2001).
- [10] D. Koch, Meggen. "Apparatus for cutting and insulation stripping of an electrical cable," April 5 2016.
- [11] A. Virkler and S. Jackson, "Wire strip and crimp tool", United State Patent, 0113804 A1, April 30, 2015.
- [12] S. Viviroli, B. Zemp and C. Schnellmann, "Method of striping a cable," United State Patent 9,397,488 B2, July19, 2016.
- [13] P. Wagner, M. Fey, "Method of cutting material to be cut," United State Patent 0054645 A1, Feb 21, 2019.

- [14] “3D Printer Motor Synchronous Timing Belt Pulley Wheel”, [online]  
[https://www.ebay.com/itm/4-10mm-Bore-XL10-20-25-30-3D-Printer-Motor-Synchronous-Timing-Belt-Pulley-Wheel/232260319917?\\_trkparms=aid%3D555018%26algo%3DPL.SIM%26ao%3D1%26asc%3D20131003132420%26meid%3Dce6de92d97d643b09346c72fc52f0253%26pid%3D100005%26rk%3D6%26rkt%3D12%26sd%3D231276239643%26itm%3D232260319917%26pg%3D2047675&\\_trksid=p2047675.c100005.m1851,2017](https://www.ebay.com/itm/4-10mm-Bore-XL10-20-25-30-3D-Printer-Motor-Synchronous-Timing-Belt-Pulley-Wheel/232260319917?_trkparms=aid%3D555018%26algo%3DPL.SIM%26ao%3D1%26asc%3D20131003132420%26meid%3Dce6de92d97d643b09346c72fc52f0253%26pid%3D100005%26rk%3D6%26rkt%3D12%26sd%3D231276239643%26itm%3D232260319917%26pg%3D2047675&_trksid=p2047675.c100005.m1851,2017).
- [15] “Stepper motor torque characteristics”, [online]  
[https://www.researchgate.net/figure/Stepper-motor-torque-characteristics-Appendix-E-Data-Sheets\\_fig10\\_299134929](https://www.researchgate.net/figure/Stepper-motor-torque-characteristics-Appendix-E-Data-Sheets_fig10_299134929), 2016.
- [16] “Position Control of Stepping Motor”, [online] <http://www.rroj.com/open-access/pdfdownload.php?download=position-control-of-stepping-motor.pdf&aid=42947>, 2017
- [17] S. Temel and Yagil, “Discrete time control system”, [online]  
<https://www.academia.edu/27666692/EE402RecitationReport>, 2017
- [18] “L296 Monolithic Power Switching Regulator Data sheet,” SCG Microelectronics, Australia.
- [19] G. Frey and L. Litz, Formal methods in PLC programming, IEEE International Conference, vol.4, no.7, pp. 2431-2436, Dec 5, 2000.
- [20] R. Ali and M. A. Shuail, “Direct Load Control Using a Programmable Logic Controller”. Electric Power Systems Research, vol.52, no.3, pp. 211-216, Sep 5, 1999.
- [21] K Ball, PLC I/O systems news, views and networks, Control Engineering, vol.44, no.14, pp. 81-88, April 23, 1997.