

**CORRELATION BETWEEN POINT LOAD STRENGTH
INDEX AND UNIAXIAL COMPRESSIVE STRENGTH
FOR HARD CRYSTALLINE ROCK**

J. M. S. T. W. Jayasinghe

(168960K)

Degree of Master in Engineering

Department of Civil Engineering

University of Moratuwa

Sri Lanka

September 2020

**CORRELATION BETWEEN POINT LOAD STRENGTH
INDEX AND UNIAXIAL COMPRESSIVE STRENGTH
FOR HARD CRYSTALLINE ROCK**

J. M. S. T. W. Jayasinghe

(168960K)

Thesis submitted in partial fulfillment of the requirements for the degree of Master in
Engineering

Department of Civil Engineering

University of Moratuwa

Sri Lanka

September 2020

DECLARATION OF THE CANDIDATE

I declare that, this is my own work and this thesis / dissertation does not incorporate without acknowledgement any material previously submitted for a Degree or Diploma in any University or other institute of higher learning and to the best of my knowledge and belief it does not contain any material previously published or written by another person except where the acknowledgement is made in the text.

Also, I hereby grant to University of Moratuwa the non-exclusive right to reproduce and distribute my thesis/dissertation, in whole or in part in print, electronic or other medium. I retain the right to use this content in whole or part in future works.

.....

Date:

J.M.S.T.W. Jayasinghe (168960K)

DECLARATION OF THE SUPERVISORS

We have supervised and accepted this thesis for submission for the degree.

.....

Date:

Prof. U. G. A. Puswewala

.....

Date:

Eng. Mahinda Rathnasiri

ABSTRACT

Large scale constructions such as highways, bridges, high rise buildings, jetties etc. are designed to withstand heavy loads depending on the dead loads and imposed loads on the structure. For this purpose, loads from these super structures are to be transferred to competent rock by adopting pile foundations. For end bearing piles, rock socketing has to be done to the competent rock. To identify competent rock, generally, the Point Load Strength (PLS) index ($I_{s(50)}$) of a rock sample collected during the rock drilling work is determined and the Unconfined Compressive Strength value of the same sample is estimated. If the Unconfined Compressive Strength value is acceptable, the pile can be terminated. For estimating the Unconfined Compressive Strength value from the Point Load Strength value, there are some correlations which are generally used in the Sri Lankan construction practice. All of these correlations are outcomes of research work done in overseas countries. Therefore, this research is an effort of finding an acceptable correlation between the Point Load Strength value and the Unconfined Compressive Strength value for crystalline metamorphic rocks found in Sri Lanka to be used as a guideline for pile termination criteria. More than 130 rock samples were collected from different rock types and both the Unconfined Compressive Strength value and the Point Load Strength index of the same rock were determined by conducting laboratory tests. In addition to these two tests, the Specific Gravity (SG) value of the same rock was determined and the rock type was also identified visually to group/ classify the data according to the rock type. After analyzing the test data gathered, a correlation between the Unconfined Compressive Strength value and the Point Load Strength index was established for different rock types. Few samples from each rock type were used for validating the correlations established.

Key Words: Crystalline Metamorphic Rocks, Unconfined Compressive Strength, Point Load Strength index

DEDICATION

I dedicate this research project report to,

My supervisors, Prof. U. G. A. Puswewala and Eng. Mahinda Rathnasiri,

Research project coordinator, Prof. S. A. S. Kulathilake and other staff members of the Civil Engineering department.

To all the students, authorities and researchers who are having an interest in the field of Geotechnical Engineering and who will be benefited from the findings of this research.

Name: J.M.S.T.W. Jayasinghe (168960K)

ACKNOWLEDGEMENT

I would like to acknowledge and extend our heartfelt gratitude to the following personnel who helped us in various ways to complete this research project;

Project supervision panel; Prof. U. G. A. Puswewala, former Dean of Faculty of Engineering, University of Moratuwa, currently Professor at the Department of Civil Engineering, Faculty of Engineering, University of Moratuwa and Eng. Mahinda Rathnasiri, Chartered Civil Engineer, General Manager of Engineering & Laboratory Services (Pvt) Ltd. and ELS Construction (Pvt) Ltd. Companies for the constant reminders, much needed motivation, vital encouragement and support provided throughout the period.

Prof. S. A. S. Kulathilake, research coordinator of the Department of Civil Engineering for the kind guidance given.

Officials of the Library, University of Moratuwa for their support given to purchase related research papers.

All the staff of the Main Laboratory of Engineering & Laboratory Services (Pvt) Ltd. for their support given for conducting the tests and preparing test reports on time.

At last but not least my grateful thanks are expressed to everyone who helped in numerous ways to make this project a success.

Name: J.M.S.T.W. Jayasinghe (168960K)

Date:

CONTENTS

DECLARATION OF THE CANDIDATE	iii
DECLARATION OF THE SUPERVISORS.....	iv
ABSTRACT.....	v
DEDICATION.....	vi
ACKNOWLEDGEMENT	vii
LIST OF FIGURES	x
LIST OF TABLES.....	xi
LIST OF ABBREVIATIONS.....	xi
LIST OF ANNEXTURES	xii
CHAPTER 01: INTRODUCTION	1
1.1. Background of the Research Project.....	1
1.2. Problem Statement.....	2
1.3. Problem Justification	2
1.4. Significance of the project	3
1.5. Objectives of the project	4
1.6. Overview of the Report.....	4
CHAPTER 02: LITERATURE REVIEW	5
2.1. Laboratory determination of Point Load Strength	5
2.2. Laboratory determination of Uniaxial Compressive Strength	8
2.3. Laboratory determination of Specific Gravity of rock samples	9
2.4. Previous research findings related to the development of correlations between UCS and PLI.....	11
CHAPTER 03: METHODOLOGY	14
3.1. Study of previous researches	14
3.2. Collection of rock samples for laboratory testing	14
3.3. Conducting Laboratory tests	15
3.4. Analyzing the test results obtained from laboratory tests	19
3.5. Establishing a suitable correlation between UCS and PLI and validating the correlations.....	20
CHAPTER 4: RESULTS AND DISCUSSION.....	21
4.1. Laboratory test results obtained	21
4.2. Analysis of the results.....	25

4.2.1. Granulitic Gneiss rock samples	26
4.2.2. Garnet Granulite rock samples.....	28
4.2.3. Charnokitic Gneiss rock samples	30
4.2.4. Biotite Gneiss rock samples.....	32
4.2.5. Garnet Biotite Gneiss rock samples	34
4.3. Validation of the correlations established	36
4.3.1. Granulitic Gneiss rock samples	36
4.3.2. Garnet Granulite rock samples.....	37
4.3.3. Charnokitic Gneiss rock samples	38
4.3.4. Biotite Gneiss rock samples.....	39
4.3.5. Garnet Biotite Gneiss rock samples	41
CHAPTER 5: CONCLUSIONS AND RECOMMENDATIONS	43
5.1. Conclusions.....	43
5.2. Recommendations.....	45
REFERENCES	46

LIST OF FIGURES

Figure 1.1: Typical cross section of a rock socketed pile	2
Figure 1.2: Nature of the rock samples recoverable during pile coring	3
Figure 1.3: Geological map of Sri Lanka showing the major geological units	3
Figure 2.1: Load Configurations and Specimen Shape Requirement for (a) the Diametral Test, (b) the Axial Test, (c) the Block Test, and (d) the Irregular Lump Test	5
Figure 2.2: Typical modes of failure for valid and invalid tests (a) valid diametral tests, (b) valid axial tests, (c) valid block tests, and (d) invalid core test and (e) invalid axial test (point load strength index tests)	6
Figure 2.3: Typical machine used to conduct the Point Load Strength Index test	6
Figure 2.4: Typical machine used to conduct the Unconfined Compression test	8
Figure 2.5: The wire basket method testing apparatus used to conduct the specific gravity test	10
Figure 2.6: Correlation between UCS and PLI for Shale specimens	11
Figure 2.7: Correlation between UCS and PLI for Marlstone specimens	12
Figure 2.8: Relation between UCS and $I_{s(50)}$ for group A rocks	13
Figure 2.9: Relation between UCS and $I_{s(50)}$ for group B rocks	13
Figure 3.1: Some of the rock core samples collected from bore hole investigation sites	15
Figure 3.2: Preparation of rock samples for Unconfined Compression Test	16
Figure 3.3: Rock core samples after the end preparation for Unconfined Compression Test	16
Figure 3.4: Conducting Unconfined Compression Test on the prepared rock core specimens	17
Figure 3.5: Conducting Point Load Index Test on the prepared rock core specimens	17
Figure 3.6: Rock core samples prepared for Specific Gravity Test	18
Figure 3.7: Conducting Specific Gravity test on rock samples as per the wire basket method	18
Figure 4.1: Relation between UCS value and $I_{s(50)}$ for Granulitic Gneiss rock samples	26
Figure 4.2: Relation between UCS value and $I_{s(50)}$ for Garnet Granulite rock samples	28
Figure 4.3: Relation between UCS value and $I_{s(50)}$ for Charnokitic Gneiss rock samples	30
Figure 4.4: Relation between UCS value and $I_{s(50)}$ for Biotite Gneiss rock samples	32
Figure 4.5: Relation between UCS value and $I_{s(50)}$ for Garnet Biotite Gneiss rock samples	34
Figure 5.1: Relation between UCS value and $I_{s(50)}$ for all rock types analyzed	44
Figure 5.2: Comparison of the correlations established among UCS value and $I_{s(50)}$ by other researchers	45
AnnexA: Sample UCS Test reports for Granulitic Gneiss Rock specimens tested	47
AnnexB: Sample PLI Test reports for Granulitic Gneiss Rock specimen tested	48
AnnexC: Sample SG Test reports for Granulitic Gneiss Rock specimen tested	49
AnnexD: Sample UCS Test reports for Garnet Granulite Rock specimen tested	50
AnnexE: Sample PLI Test reports for Garnet Granulite Rock specimen tested	51
AnnexF: Sample SG Test reports for Garnet Granulite Rock specimen tested	52
AnnexG: Sample UCS Test reports for Charnokitic Gneiss Rock specimen tested	53
AnnexH: Sample PLI Test reports for Charnokitic Gneiss Rock specimen tested	54
AnnexI: Sample SG Test reports for Charnokitic Gneiss Rock specimen tested	55
AnnexJ: Sample UCS Test reports for Biotite Gneiss Rock specimen tested	56
AnnexK: Sample PLI Test reports for Biotite Gneiss Rock specimen tested	57
AnnexL: Sample SG Test reports for Biotite Gneiss Rock specimen tested	58

AnnexM: Sample UCS Test reports for Garnet Biotite Gneiss Rock specimenstested	59
AnnexN: Sample PLI Test reports for Garnet Biotite Gneiss Rock specimenstested	60
AnnexO: Sample SG Test reports for Garnet Biotite Gneiss Rock specimenstested	61

LIST OF TABLES

Table 2.1: Typical specific gravity values of rocks	9
Table 2.2: Rock Groups Identified by Scatter Plot of UCS and $I_{s(50)}$	12
Table 4.1: Summary of number of tests conducted for the analysis	21
Table 4.2: UCS, PLI and SG test results of Granulitic Gneiss rock samples	22
Table 4.3: UCS, PLI and SG test results of Garnet Granulite rock samples	22
Table 4.4: UCS, PLI and SG test results of Charnokitic Gneiss rock samples	22
Table 4.5: UCS, PLI and SG test results of Biotite Gneiss rock samples	23
Table 4.6: UCS, PLI and SG test results of Garnet Biotite Gneiss rock samples	25
Table 4.7: Deviation of UCS from predicted value for granulitic gneiss rock	36
Table 4.8: Deviation of UCS from predicted value for garnet granulitic rock	38
Table 4.9: Deviation of UCS from predicted value for charnokitic gneiss rock	38
Table 4.10: Deviation of UCS from predicted value for biotite gneiss rock	40
Table 4.11: Deviation of UCS from predicted value for biotite gneiss rock	42

LIST OF ABBREVIATIONS

Abbreviation	Description
UCS	Unconfined Compressive Strength
PLS	Point Load Strength
SG	Specific Gravity
PLT	Point Load Test
D_e	Standard Equivalent Diameter
P_u	Failure Load
PLI	Point Load Strength Index
ASTM	American Society for Testing and Materials
UCT	Unconfined Compression Test
BS	British Standard

LIST OF ANNEXTURES

- Annex A: Sample UCS Test reports for Granulitic Gneiss Rock specimens tested
- Annex B: Sample PLI Test reports for Granulitic Gneiss Rock specimens tested
- Annex C: Sample SG Test reports for Granulitic Gneiss Rock specimens tested
- Annex D: Sample UCS Test reports for Garnet Granulite Rock specimens tested
- Annex E: Sample PLI Test reports for Garnet Granulite Rock specimens tested
- Annex F: Sample SG Test reports for Garnet Granulite Rock specimens tested
- Annex G: Sample UCS Test reports for Charnokitic Gneiss Rock specimens tested
- Annex H: Sample PLI Test reports for Charnokitic Gneiss Rock specimens tested
- Annex I: Sample SG Test reports for Charnokitic Gneiss Rock specimens tested
- Annex J: Sample UCS Test reports for Biotite Gneiss Rock specimens tested
- Annex K: Sample PLI Test reports for Biotite Gneiss Rock specimens tested
- Annex L: Sample SG Test reports for Biotite Gneiss Rock specimens tested
- Annex M: Sample UCS Test reports for Garnet Biotite Gneiss Rock specimens tested
- Annex N: Sample PLI Test reports for Garnet Biotite Gneiss Rock specimens tested
- Annex O: Sample SG Test reports for Garnet Biotite Gneiss Rock specimens tested

CHAPTER 01: INTRODUCTION

1.1. Background of the Research Project

The construction industry in the country is now evolving and several large scale constructions such as highways, bridges, high rise buildings and jetties are under construction. All of these constructions are designed to withstand heavy loads depending on the dead loads and imposed loads on the structure. For this purpose, a competent ground should be available to bear these heavy loads. The loads from these super structures are transferred to the ground through a suitable foundation. If the prevailing ground conditions at shallow depth are not favorable, the loads have to be transferred to the deep competent rock by adopting a pile foundation. It can be a driven or bored pile foundation. The construction of bored pile foundation involves several design and practical considerations including use of proper drilling techniques, cleaning of the hole, drilling termination criteria, proper placement of reinforcement nets, concreting and many other criteria. To understand the depth to which the drilling in to the rock is to be done for rock socketing, the quality of rock at the bottom of the hole has to be determined. If sound rock is present, the drilling work can be terminated and the next step of the foundation work can be proceeded.

To understand the quality of the rock encountered in drilling work, the most common physical property used is the results obtained from Uniaxial Compressive Strength (UCS) test. For conducting a UCS test, a cylindrical rock sample of sufficient diameter and height (Height to Diameter ratio of 2:1) is required. But, in the rock socketing work, such type of sample is rarely obtained. Therefore, the common practice in the construction industry is to check the Point Load Strength index of a rock sample collected during the rock drilling work and estimating the UCS value of the same sample. For estimating the UCS value from the Point Load Strength index, there are some correlations which are generally used in the Sri Lankan construction practice. All of these correlations are outcomes of research work done in overseas countries. This research is an effort of finding an acceptable correlation between the Point Load Strength value and the UCS value for the rocks found in Sri Lanka, which are mostly crystalline metamorphic rocks.

1.2. Problem Statement

The depth into which the rock drilling has to be done for bored pile foundation work basically depends on the quality of the rock available. To accurately estimate the UCS value of the rock found, a guaranteed and validated method has to be available. Since the general practice of predicting the UCS value of a rock from Point Load Strength index is based on some empirical correlations which are based on research findings for rocks available in other countries, it is very important to answer the questions that, to which extent are these relationships valid for locally available rocks. If these correlations are not valid for locally available rocks, what will be the most accurate correlation for the rocks encountered in Sri Lanka, which are mostly crystalline metamorphic rocks? Further, it is to be known that, how these correlations vary from one rock type to the other. This research is to find solutions to these major issues.

1.3. Problem Justification

As it is understood that the rock drilling termination decision shall be done based on the quality of the rock encountered, a reliable method to ensure a good quality rock is found inside the hole is essential. If the quality of the rock is predicted wrongly as competent enough to terminate the drill hole where the rock is actually not competent enough, the constructed pile foundation may not be able to withstand the designed bearing capacity.

On the other hand, if the quality of the rock is under predicted, it will be not economical and it will lead to a waste of time and labor too. Therefore, a reliable method to predict the rock quality is of utmost important. Figure 1.1 shows a typical cross section of a rock socketed pile and Figure 1.2 depicts some typical recovery from bed rock.

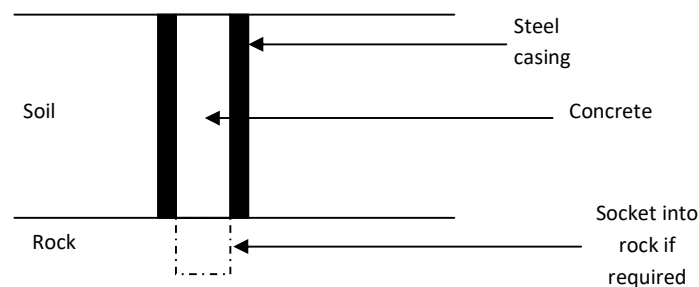

Figure 1.1: Typical cross section of a rock socketed pile



Figure 1.2: Nature of the rock samples recoverable during pile coring

(Source: <https://www.youtube.com/watch?v=aHsTFooJfq4>)

1.4. Significance of the project

Availability of an accurate method to predict the UCS value of rock cuttings from the Point Load Strength index is of prime importance as evident from the problem statement. Only a few researches have been done to find correlations among physical properties of rocks available in Sri Lanka. This research will focus on the direct use of such a correlation in rock drilling for bored pile foundation work. The variation of rock types in the Sri Lankan crust is shown in Figure 1.3.

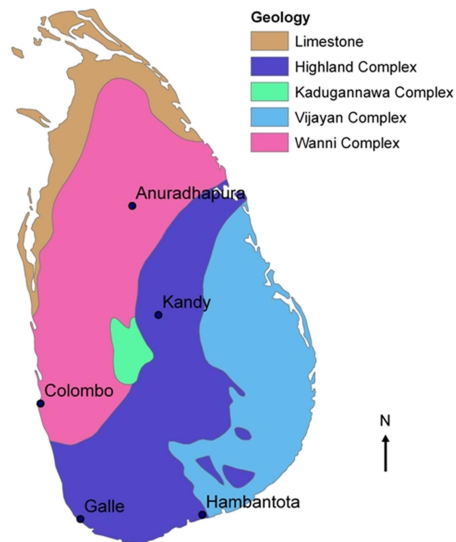

Figure 1.3: Geological map of Sri Lanka showing the major geological units

(Source: https://www.geo.shimane-u.ac.jp/spfs/g_students/mext/08sansfica/sansfica08.html)

1.5. Objectives of the project

The main objective is to find a more reliable correlation between UCS value and Point Load Strength index of different types of rock cuttings encountered in rock drilling for pile foundation in the Sri Lankan context. This will assist to decide whether to terminate the drilling or to proceed further, based on the strength of the rock.

1.6. Overview of the Report

In this chapter (chapter 01), an introduction to the research project is given including the background of the project, problem statement, problem justification, significance of the project, research objectives and a brief outline of the content of this project report.

Chapter 2 presents literature review which was referred during the research. It includes the details of findings of similar type of researches done in some overseas countries. Laboratory determination methods of Point Load Strength, Unconfined Compressive Strength value and Specific Gravity of rock specimens are also discussed here.

Chapter 3 describes the methodology adopted for the research. It outlines the work flow implemented in developing a correlation between UCS and PLS.

Chapter 4 includes the results of the research with detail analysis and discussion. This chapter describes the classification of data gathered, analysis of data, comparison of different correlations already available, development of suitable correlations for different rock types and validation method used to validate the correlations found.

Chapter 5 discusses about the conclusions obtained from the analysis of the results. The recommendations to use and improve the results and limitations of the scope of the research are also mentioned in this chapter.

CHAPTER 02: LITERATURE REVIEW

2.1. Laboratory determination of Point Load Strength

The Point Load Test (PLT) is used as an efficient and applicable method for rock classification (Broch and Franklin, 1972; Guidicini et al., 1973; Bieniawski, 1975; Brook, 1977; Greminger, 1980; Forster, 1983). Based on this method, failure of rock occurs due to tensile stress. PLT is a cost effective alternative method to indirectly obtain UCS and can be conducted on rock samples without using any special sample preparation. The point load tester can be used as a portable device at site. In PLT, rock samples are compressed between two conical steel platens until failure occurs.

American Society for Testing and Materials has established the basic procedure for conducting and calculation of point load strength index (ASTM D5731).

There are four main types of PLT; axial, diametral, block and irregular lump test, as depicted in Figure 2.1. Typical modes of failure for valid and invalid tests are shown in Figure 2.2. Figure 2.3 shows a typical machine to conduct the PLS index test.

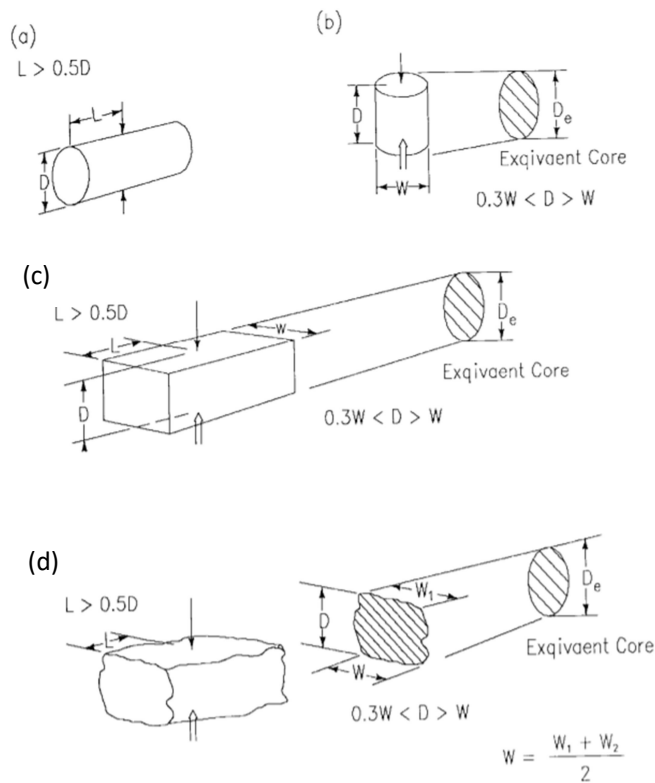

Figure 2.1: Load Configurations and Specimen Shape Requirement for (a) the Diametral Test, (b) the Axial Test, (c) the Block Test, and (d) the Irregular Lump Test
(Source: ASTM D 5731)

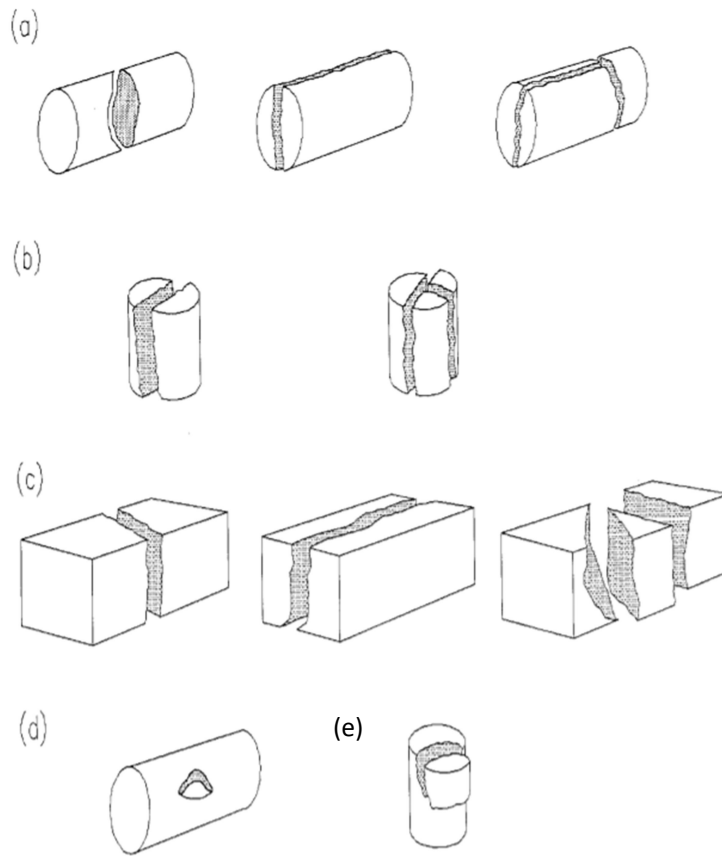

Figure 2.2: Typical modes of failure for valid and invalid tests (a) valid diametral tests, (b) valid axial tests, (c) valid block tests, and (d) invalid core test and (e) invalid axial test (point load strength index tests)
 (Source: ASTM D 5731)



Figure 2.3: Typical machine used to conduct the Point Load Strength Index test
 (Source: <http://www.floxlab.com/plt-100-point-load-tester-41.aspx>)

Using the point load strength testing machine as shown in figure 2.3, the specimen can be tested according to one of the four types described in the Figure 2.1. The calculation of the PLI can be done as follows:

Uncorrected Point Load Strength Index (I_s) is calculated as:

$$I_s = P/D_e^2 \quad (\text{Equation 2.1})$$

where:

P = failure load

D_e = equivalent core diameter which is equal to D for diametral tests

D_e^2 = D^2 for cores

D_e^2 = $4A/\pi$ for axial, block and lump test;

where:

A = WD = minimum cross-sectional area of a plane through the platen contact points

The point load strength index determined by PLT must be corrected to the standard equivalent diameter (D_e) of 50mm (Peng and Zhang, 2007). It can be done as follows:

$$I_{s(50)} = F \times I_s \quad (\text{Equation 2.2})$$

The “Size Correction Factor F ” can be obtained from the expression:

$$F = (D_e/50)^{0.45} \quad (\text{Equation 2.3})$$

2.2. Laboratory determination of Uniaxial Compressive Strength

Uniaxial compression test is a most commonly used laboratory test to investigate mechanical properties of intact rocks. The results of UCT are used in most of engineering projects.

The methodology for UCS is standardized by International Society of Rock Mechanics (ISRM, 1981) and American Society for Testing and Materials (ASTM D 2938).



Figure 2.4: Typical machine used to conduct the Unconfined Compression test

(Source: <https://i.ytimg.com/vi/yN9nrUIYmZw/maxresdefault.jpg>)

In UCT, the length-to-diameter ratio of samples should be in the order of two. UCS value can be calculated using the following simple Equation:

$$UCS = \frac{F}{A} \quad (\text{Equation 2.4})$$

Where F and A are maximum applied load and specimen cross sectional area, respectively. If the length to diameter ratio is not in the order of two, UCS value should be corrected as following equation, according to ASTM standard:

$$UCS^* = \frac{UCS}{0.88 + \left(\frac{0.24d}{h}\right)} \quad (\text{Equation 2.5})$$

Where UCS* is the corrected UCS for h/d=2. Parameters h, d, and A are the height, diameter and cross sectional area of the specimen, respectively.

2.3. Laboratory determination of Specific Gravity of rock samples

Specific gravity of a rock can be used as a basis for the identification of the type of rock since the specific gravity values vary with the rock type. Some typical values of naturally occurring rock types are tabulated below.

Table 2.1: Typical specific gravity values of rocks

(Source: <http://www.edumine.com/xtoolkit/tables/sgtables.htm> and https://www.engineeringtoolbox.com/minerals-specific-gravity-d_1644.html)

Rock type	Specific Gravity (g/cm ³)
Granite	2.60-2.70
Sandstone	2.00-2.60
Shale	2.00-2.40
Limestone	2.20-2.60
Quartzite	2.65
Gneiss	2.7

The determination of specific gravity of rocks can be done in the laboratory as per the method specified in the British Standard (BS) 812-Part 2 or ASTM D 6473. Wire basket method mentioned in the ASTM standard is described here. The following equations will be used in the calculation of specific gravity of rock specimens.

- Particle density on an oven dried basis: (g/cm³)

$$\frac{D}{A-(B-C)} \quad (\text{Equation 2.6})$$

- Particle density on a Saturated and Surface Dried (SSD) basis: (g/cm³)

$$\frac{A}{A-(B-C)} \quad (\text{Equation 2.7})$$

- The apparent Particle density: (g/cm³)

$$\frac{D}{D-(B-C)} \quad (\text{Equation 2.8})$$

Where;

A-mass of SSD sample in air.

B-apparent mass of the basket containing the saturated sample in water.

C-apparent mass of the empty basket in water.

D-mass of the oven dried aggregate sample in air.



Figure 2.5: The wire basket method testing apparatus used to conduct the specific gravity test

(Source: <https://image.slidesharecdn.com/aggregates-170128204404/95/classification-properties-and-extraction-of-aggregates-29-638.jpg?cb=1485686464>)

2.4. Previous research findings related to the development of correlations between UCS and PLI

Estimating the UCS value from the Point Load Strength value is entirely based on research findings. This type of research work has been done in several countries for the rock types available in those countries and they have prepared a basic correlation to be used in their construction sites. Some of this work are summarized here.

Mahtab Alitalesh et al. (2016) have conducted investigations to find a correlation between uniaxial compressive strength and point load index of rocks in three sites of Iran. They have used Shale and Marlstone in the research. The results of tests on shale indicated a good agreement with the pervious relationships. Figures 2.6 and 2.7 are after them.

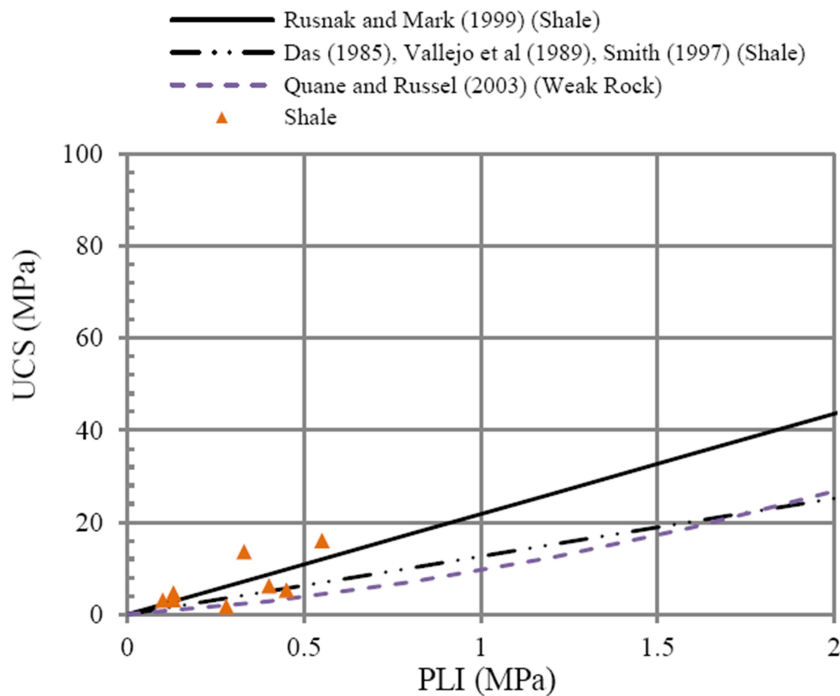

Figure 2.6: Correlation between UCS and PLI for Shale specimens
(Mahtab et al., 2016)

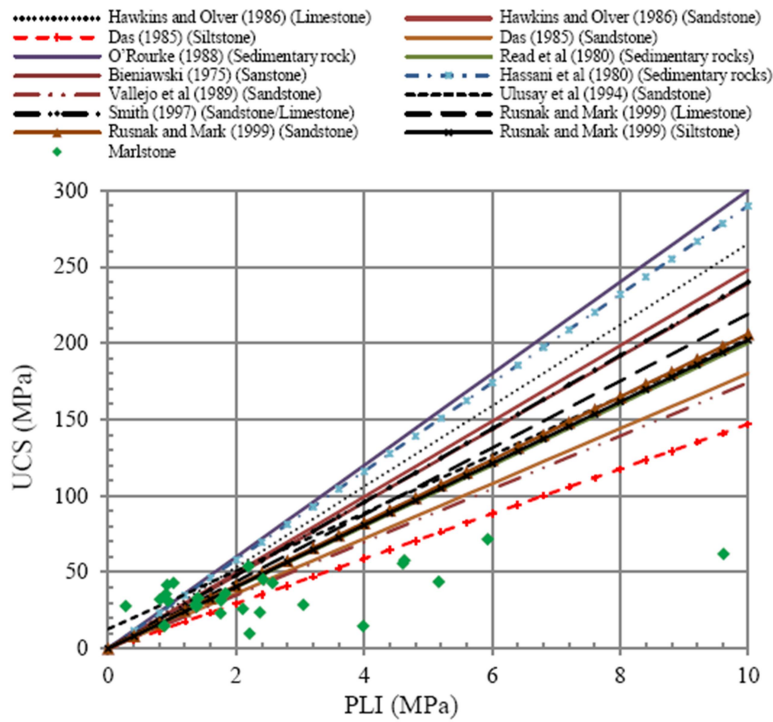

Figure 2.7: Correlation between UCS and PLI for Marlstone specimens
(Mahtab et al., 2016)

Akram and Bakar (2007) had done a research for rocks found in Pakistan. They have used nine rock types including Sandstone, Limestone, Siltstone, Dolomite and Marl collected from six different formations of the Salt Range area of Pakistan. They have grouped the rock types in to two major groups as Group A and Group B rocks. Rock groups have been identified by a scatter plot of UCS and $I_{s(50)}$. Table 2.2, and figures 2.8 and 2.9 show their results.

Table 2.2: Rock Groups Identified by Scatter Plot of UCS and $I_{s(50)}$
(Akram and Bakar, 2007)

Rocks group A	Rocks group B
Jutana Sandstone	Dandot Sandstone
Baghanwala Sandstone	Sakessar Nodular Limestone
Siltstone	Marl
Sakessar Massive Limestone	
Khewra Sandstone	
Dolomite	

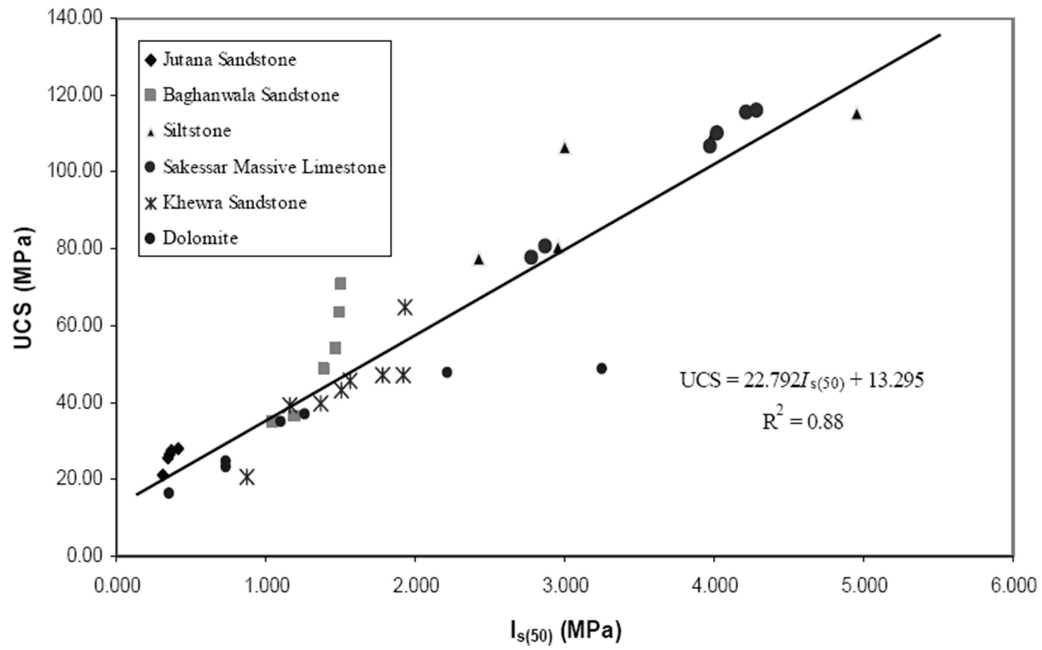

Figure 2.8: Relation between UCS and $I_{s(50)}$ for group A rocks
(Akram and Bakar, 2007)

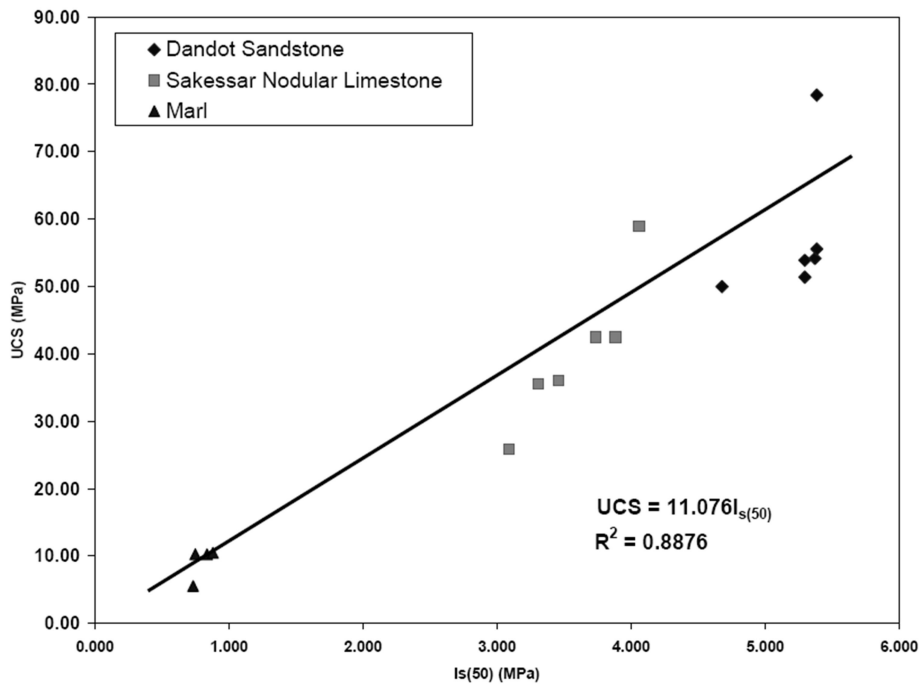

Figure 2.9: Relation between UCS and $I_{s(50)}$ for group B rocks
(Akram and Bakar, 2007)

CHAPTER 03: METHODOLOGY

Rock samples required for conducting the UCT, PLT and SG tests were collected from different sites. Above rock samples collected were grouped based on their visual appearance. After that, the UCT and PLT were conducted in the laboratory and the test results were analyzed to find a correlation. After establishing correlations, few more samples were tested for UCS and PLI to validate the correlations established.

The workflow followed to analyze and ultimately establish a correlation between UCS and PLI is outlined below.

3.1. Study of previous researches

Previous researches done regarding this subject area (overseas) were studied to identify the methodology they had adopted and the correlations they had established. Based on this literature study, it was decided to select rock samples from different rock types from different sites. Commonly available rock types in Sri Lanka were used in the research.

3.2. Collection of rock samples for laboratory testing

Rock core samples were collected from borehole investigation sites in different areas of the country. When bore hole drilling is done in to the rock, normally, a sufficient length of rock core is recovered. It was possible to collect 136 rock core samples from different areas. The areas from which samples were collected basically covered the Western and North Western Provinces of the country. Rock core samples from following major rock types were collected.

Granulitic Gneiss-This is a metamorphic rock of high grade. This contains a gneissic texture in granulite which contains medium to coarse grains. 10 samples from this rock type were used for the analysis and 2 samples for validation of the correlation.

Garnet Granulite-This is a granulitic rock containing garnet grains. Garnet can be identified by its distinct red colour. This is a high grade metamorphic rock. 12 samples from this rock type were used for the analysis and 5 samples for validation of the correlation.

Charnokitic Gneiss-This is a charnokitic rock with gneissic texture. Charnokite can be identified by its distinct green colour. This is also a high grade metamorphic rock. 10 samples from this rock type were used for the analysis and 2 samples for validation of the correlation.

Biotite Gneiss-This is high grade metamorphic rock with a gneissic texture. This contains Biotite Mica also. It is easy to identify Biotite Mica due to its black color. 89 samples from this rock type were used for the analysis and 8 samples for validation of the correlation.

Garnet Biotite Gneiss- This is also a rock with gneissic texture. This contains both garnet and biotite. These can be identified by their distinct colors. This is also a high grade metamorphic rock. 15 samples from this rock type were used for the analysis and 5 samples for validation of the correlation.



Figure 3.1: Some of the rock core samples collected from bore hole investigation sites. The collected rock cores were grouped into different types of rocks. Thereafter, the rock cores were prepared for laboratory testing.

3.3. Conducting Laboratory tests

After grouping the rock cores, the core samples were prepared for the UCT and PLT laboratory tests. The SG determination was also done for the same rock sample. Figures 3.2 and 3.3 show preparation of rock samples for UCT, and Figures 3.4 and 3.5 show conduction of UCT and PLT tests, respectively. Figures 3.6 and 3.7 show steps in conduction of SG tests.



Figure 3.2: Preparation of rock samples for Unconfined Compression Test



Figure 3.3: Rock core samples after the end preparation for Unconfined Compression Test



Figure 3.4: Conducting Unconfined Compression Test on the prepared rock core specimens



Figure 3.5: Conducting Point Load Index Test on the prepared rock core specimens



Figure 3.6: Rock core samples prepared for Specific Gravity Test



Figure 3.7: Conducting Specific Gravity test on rock samples as per the wire basket method

3.4. Analyzing the test results obtained from laboratory tests

The UCS, PLI and SG values obtained from the laboratory testing series were classified and analyzed to find a correlation between UCS and PLI for different rock types. Following statistical parameters were used in the analysis.

1. Standard deviation (σ)

$$\text{Standard deviation} = \sqrt{\frac{1}{N} \sum_{i=1}^N ((x_i - \mu)^2)} \quad (\text{Equation 3.1})$$

Where;

μ -Mean value

$X_{i-i^{\text{th}}}$ data value

N-number of data

2. Coefficient of correlation (r)

$$r = \frac{[n(\sum xy) - (\sum x)(\sum y)]}{\sqrt{[n \sum x^2 - (\sum x)^2][n \sum y^2 - (\sum y)^2]}} \quad (\text{Equation 3.2})$$

3. Coefficient of determination (R^2)

$$R^2 = \frac{[n(\sum xy) - (\sum x)(\sum y)]^2}{[n \sum x^2 - (\sum x)^2][n \sum y^2 - (\sum y)^2]} \quad (\text{Equation 3.3})$$

Where;

r = The Correlation coefficient

n = number in the given dataset

R^2 = Coefficient of determination

x = first variable in the context

y = second variable

The following points are the accepted guidelines for interpreting the coefficient of correlation (r) [Palgrave (2009)]

1. 0 indicates no linear relationship.
2. +1 indicates a perfect positive linear relationship – as one variable increases in its values, the other variable also increases in its values through an exact linear rule.
3. -1 indicates a perfect negative linear relationship – as one variable increases in its values, the other variable decreases in its values through an exact linear rule.
4. Values between 0 and 0.3 (0 and -0.3) indicate a weak positive (negative) linear relationship through a shaky linear rule.
5. Values between 0.3 and 0.7 (0.3 and -0.7) indicate a moderate positive (negative) linear relationship through a fuzzy-firm linear rule.
6. Values between 0.7 and 1.0 (-0.7 and -1.0) indicate a strong positive (negative) linear relationship through a firm linear rule.

The coefficient of determination gives an idea of how many data points fall within the results of the line formed by the regression equation. A higher coefficient is an indicator of a better fit for the observations. (Statisticshowto.com)

3.5. Establishing a suitable correlation between UCS and PLI and validating the correlations

After analyzing the results statistically as above, the most suitable linear correlation was selected for different rock types. Then a few rock samples from different rock types were tested for UCS, PLI and SG to validate the selected correlations.

CHAPTER 4: RESULTS AND DISCUSSION

The results obtained by performing the methodology mentioned in the previous chapter are described here followed by the analysis and discussion of the results.

4.1. Laboratory test results obtained

As mentioned in the methodology, UCS, PLI and SG tests were done on the rock core samples collected. Altogether, the total number of samples tested is summarized as follows.

Table 4.1: Summary of number of tests conducted for the analysis

Rock type	Total Number of UCS/PLI/SG tests conducted
Granulitic Gneiss	10 UCS, 10 PLI and 10 SG tests
Garnet Granulite	12 UCS, 12 PLI and 12 SG tests
Charnokitic Gneiss	10 UCS, 10 PLI and 10 SG tests
Biotite Gneiss	89 UCS, 89 PLI and 89 SG tests
Garnet Biotite Gneiss	15 UCS, 15 PLI and 15 SG tests

The test results obtained from conducting UCS and SG tests on each rock type are summarized below.

It is to be noted that, when calculating PLI, as per the test method, an average of 10 results has to be considered. But, depending on the sample availability, the maximum number of tests possible per sample was conducted. Required number of tests was conducted when sufficient amount of samples were available.

Table 4.2: UCS, PLI and SG test results of Granulitic Gneiss rock samples

Sample reference	SG value	UCS value (MPa)	PLI value (MPa)
119	2.67	61.53	6.82
120	2.78	67.21	7.74
121	2.75	48.61	5.29
122	2.97	70.01	7.41
123	2.96	52.79	5.84
124	2.95	47.07	6.51
125	2.84	67.32	8.33
140	2.75	54.21	6.15
152	2.80	85.12	7.95
154	2.91	52.73	6.45
155	2.82	60.27	7.61

Table 4.3: UCS, PLI and SG test results of Garnet Granulite rock samples

Sample reference	SG value	UCS value (MPa)	PLI value (MPa)
83	2.84	79.35	9.15
87	2.90	66.01	8.36
88	2.85	67.58	8.48
108	2.77	61.18	7.66
111	2.71	62.01	7.33
113	2.78	59.28	6.09
114	2.68	64.54	7.92
115	2.70	34.88	7.97
132	2.86	46.20	7.68
133	2.76	68.71	9.69
134	2.73	20.25	2.00
135	2.74	22.21	2.00

Table 4.4: UCS, PLI and SG test results of Charnokitic Gneiss rock samples

Sample reference	SG value	UCS value (MPa)	PLI value (MPa)
01	2.69	70.1	8.07
02	2.68	59.25	6.43
03	2.67	65.85	7.27
04	2.65	49.62	5.25
18	2.74	57.66	4.25
25	2.73	50.27	4.2
29	2.70	40.5	3.5
30	2.67	85.62	8.65
43	2.62	32.26	3.35
44	2.63	76.84	7.76

Table 4.5: UCS, PLI and SG test results of Biotite Gneiss rock samples

Sample reference	SG value	UCS value (MPa)	PLI value (MPa)
05	2.86	45.77	5.34
06	2.85	26.53	2.84
07	2.86	42.28	4.52
08	2.84	35.29	3.87
09	2.85	52.16	5.98
10	2.82	18.25	1.91
11	2.86	27.33	2.72
12	2.85	29.26	3.13
13	2.85	27.93	4.62
16	2.64	61.26	6.85
17	2.64	57.68	6.23
19	2.67	69.55	7.91
20	2.75	68.25	7.65
21	2.80	72.58	8.61
22	2.74	21.02	2.58
23	2.75	76.46	8.29
26	2.73	70.8	8.51
27	2.75	121.25	12.11
28	2.64	138.76	12.8
31	2.63	62.52	6.94
34	2.68	93.62	8.82
36	2.87	43.78	5.36
37	2.79	46.65	3.65
38	2.67	114.54	10.25
39	2.70	54.61	9.53
40	2.69	28.25	2.59
41	2.74	30.21	2.58
42	2.79	38.43	4.56
48	2.73	51.55	8.17
49	2.75	64.22	7.05
51	2.70	26	5.24
52	2.78	42.27	1.96
53	2.75	54.23	5.99
55	2.62	65.59	7.7
63	2.91	75.3	8.75
64	2.91	59.39	5.89
65	2.88	69.54	5.73
66	2.82	81.04	5.12
67	2.90	68.48	6.45
68	2.79	77.77	7.83
69	2.75	70.22	6.03
70	2.86	75.92	8.22
71	2.86	77.59	8.75
72	2.71	89.05	6.82

73	2.76	88.55	6.85
74	2.70	81.03	7.97
75	2.70	78.29	8.87
76	2.82	59.72	9.26
77	2.79	70.67	7.6
78	2.70	41.82	4.57
79	2.71	69.07	7.99
80	2.70	63.25	7.81
81	2.64	32.87	6.05
84	2.80	68.96	10.67
85	2.85	82.97	6.36
86	2.86	92.8	6.84
89	2.70	65.97	5.78
90	2.69	63.25	5.54
91	2.87	82.75	8.33
92	2.92	91.96	7.42
94	2.86	96.23	8.05
95	2.81	71.68	7.35
96	2.80	78.85	8.05
98	2.88	52.25	5.06
99	2.86	51.84	3.69
100	2.87	51.93	5.24
101	2.86	61.02	4.82
103	2.66	70.48	7.56
104	2.69	95.89	10.57
105	2.73	41.67	5.4
106	2.72	58.85	5.96
107	2.88	70.32	5.22
109	2.83	77.27	7.64
110	2.80	59.25	5.74
129	2.76	63.27	3.49
130	2.81	30.61	3.51
143	2.95	92.92	6.41
146	2.75	77.86	7.67
148	2.89	85.52	8.59
149	2.80	76.25	7.77
150	2.76	70.29	7.25
151	2.79	58.24	5.65
157	2.64	42.91	5.11
158	2.65	64	3.22
159	2.64	68.38	4.76
160	2.90	90.45	6.97
161	2.89	80.5	6.28
163	2.74	56.66	5.5
164	2.70	56.66	5.52

Table 4.6: UCS, PLI and SG test results of Garnet Biotite Gneiss rock samples

Sample reference	SG value	UCS value (MPa)	PLI value (MPa)
32	2.66	97.3	5.68
33	2.75	135.31	5.04
35	2.77	84.23	3.13
47	2.74	152.53	8.62
50	2.69	108.53	6.24
54	2.65	103.49	3.87
57	2.62	128.91	5.96
59	2.67	94.58	5.35
60	2.60	97.66	4.2
61	2.64	138.76	8.3
93	2.88	88.21	4.39
97	2.96	102.24	4.69
102	2.82	84.25	4.78
126	2.72	98.55	5.5
127	2.72	130.79	5.6

4.2. Analysis of the results

The UCS value and PLI values obtained from laboratory tests were statistically analyzed for an acceptable coefficient of correlation (r) and after obtaining such a coefficient of correlation value for each different rock type, correlation graphs were plotted between PLI and UCS values for different rock types. The relevant linear correlation equation and coefficient of determination were calculated. The results are presented here.

When analyzing the results statistically, it was observed that, the log values of PLI and UCS fitted in a good linear regression line rather than their actual values. For the analysis, it is assumed that the data set is normally distributed and the variable PLI is a non-zero value.

Figures 4.1 to 4.5 show a relation between UCS value and $I_{s(50)}$ for Granulitic Gneiss, Garnet Granulite, Charnokitic Gneiss, Biotite Gneiss and Garnet Biotite Gneiss rock samples, respectively, which were tested.

4.2.1. Granulitic Gneiss rock samples

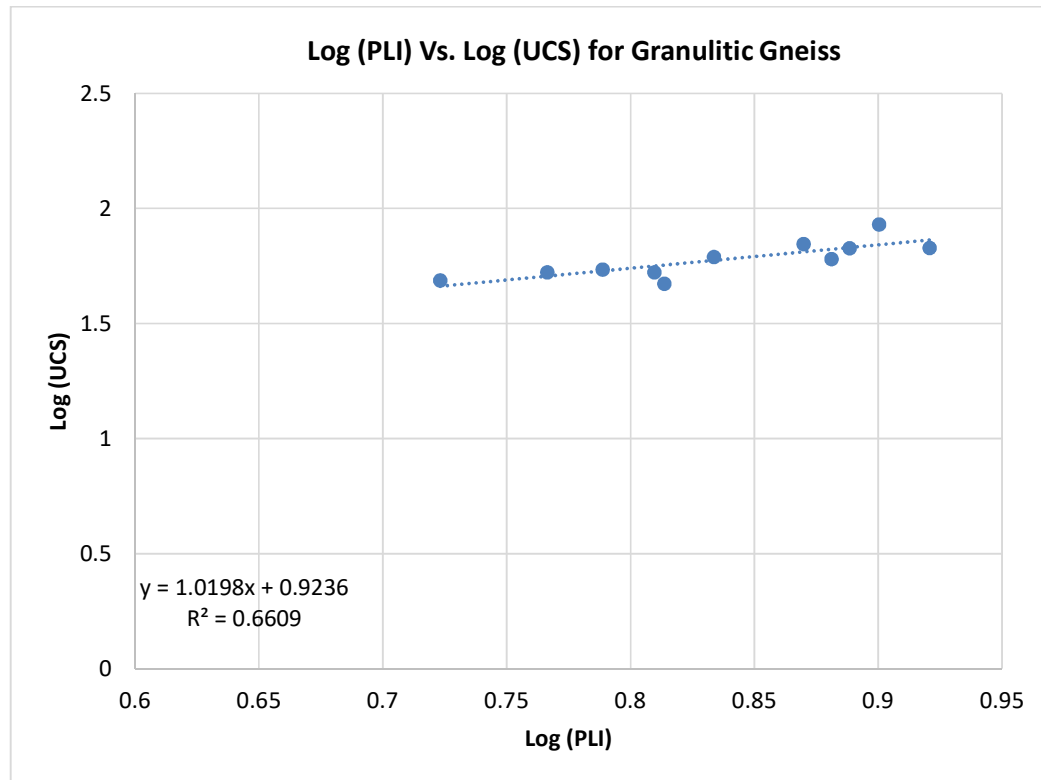

Figure 4.1: Relation between UCS value and $I_{s(50)}$ for Granulitic Gneiss rock samples

The calculated coefficient of correlation (r) of the data set between Log (PLI) and Log (UCS) is 0.81 and this indicates a strong positive linear relationship between the two parameters. The coefficient of determination (R^2) of 0.66 which is >0.5 indicates a better fitness of the observations.

The correlation equation developed is as follows:

$$Y = 1.0198X + 0.9236$$

$$\text{Log (UCS)} = 1.0198\text{Log(PLI)} + 0.9236$$

$$\text{Log (UCS)} - 1.0198\text{Log(PLI)} = 0.9236$$

$$\text{Log (UCS)} - \text{Log(PLI)}^{1.0198} = 0.9236$$

$$\text{Log} \frac{(UCS)}{(PLI)^{1.0198}} = 0.9236$$

$$\frac{(UCS)}{(PLI)^{1.0198}} = 10^{0.9236}$$

$$(UCS) = 8.3868 \times (PLI)^{1.0198}$$

The statistical analysis of the SG results obtained for Granulitic Gneiss rock samples indicates the following:

1. Mean Specific Gravity = 2.83
2. Standard Deviation of the resulted values = 0.085

4.2.2. Garnet Granulite rock samples

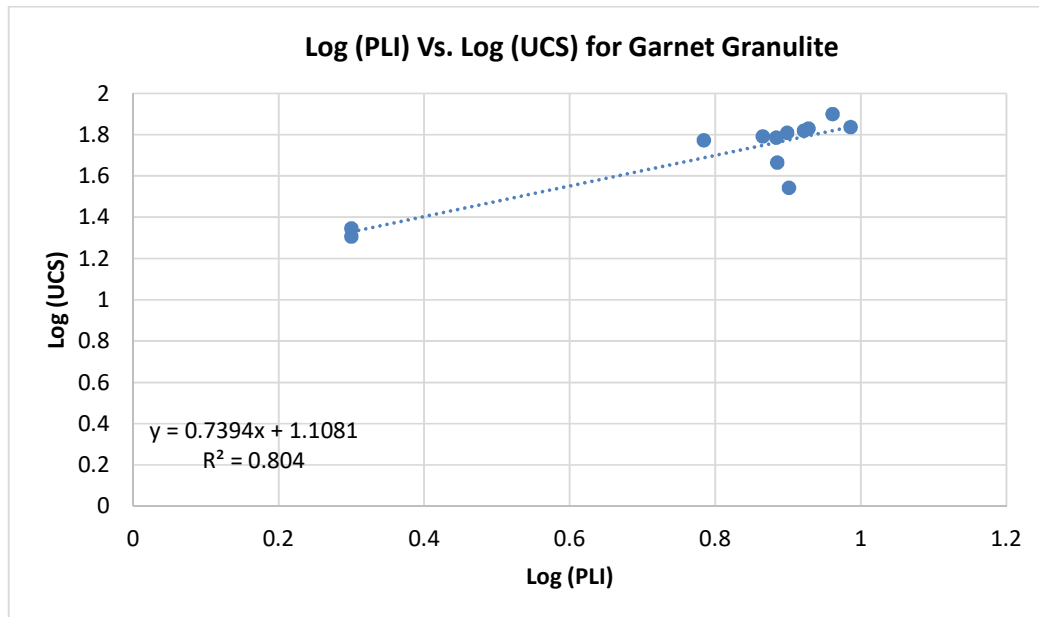

Figure 4.2: Relation between UCS value and $I_{s(50)}$ for Garnet Granulite rock samples

The calculated coefficient of correlation (r) of the data set between Log (PLI) and Log (UCS) is 0.90 and this indicates a strong positive linear relationship between the two parameters. The coefficient of determination (R^2) of 0.80 which is >0.5 indicates a better fitness of the observations.

The correlation equation developed is as follows:

$$Y = 0.7394X + 1.1081$$

$$\text{Log (UCS)} = 0.7394\text{Log(PLI)} + 1.1081$$

$$\text{Log (UCS)} - 0.7394\text{Log(PLI)} = 1.1081$$

$$\text{Log (UCS)} - \text{Log(PLI)}^{0.7394} = 1.1081$$

$$\text{Log} \frac{(UCS)}{(PLI)^{0.7394}} = 1.1081$$

$$\frac{(UCS)}{(PLI)^{0.7394}} = 10^{1.1081}$$

$$(UCS) = 12.8263 \times (PLI)^{0.7394}$$

The statistical analysis of the SG results obtained for Garnet Granulite rock samples indicates the following:

1. Mean Specific Gravity = 2.76
2. Standard Deviation of the resulted values = 0.065

4.2.3. Charnokitic Gneiss rock samples

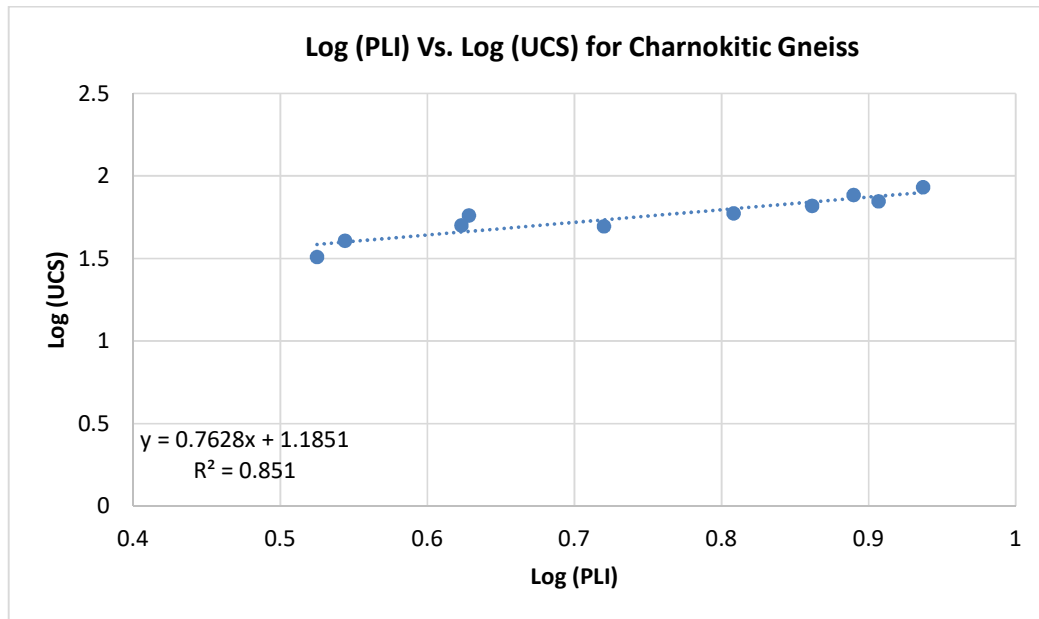

Figure 4.3: Relation between UCS value and $I_{s(50)}$ for Charnokitic Gneiss rock samples

The calculated coefficient of correlation (r) of the data set between Log (PLI) and Log (UCS) is 0.92 and this indicates a strong positive linear relationship between the two parameters. The coefficient of determination (R^2) of 0.85 which is >0.5 indicates a better fitness of the observations.

The correlation equation developed is as follows:

$$Y = 0.7628X + 1.1851$$

$$\text{Log (UCS)} = 0.7628\text{Log(PLI)} + 1.1851$$

$$\text{Log (UCS)} - 0.7628\text{Log(PLI)} = 1.1851$$

$$\text{Log (UCS)} - \text{Log(PLI)}^{0.7628} = 1.1851$$

$$\text{Log} \frac{(UCS)}{(PLI)^{0.7628}} = 1.1851$$

$$\frac{(UCS)}{(PLI)^{0.7628}} = 10^{1.1851}$$

$$(UCS) = 15.3144 \times (PLI)^{0.7628}$$

The statistical analysis of the SG results obtained for Charnokitic Gneiss rock samples indicates the following:

1. Mean Specific Gravity = 2.68
2. Standard Deviation of the resulted values = 0.036

4.2.4. Biotite Gneiss rock samples

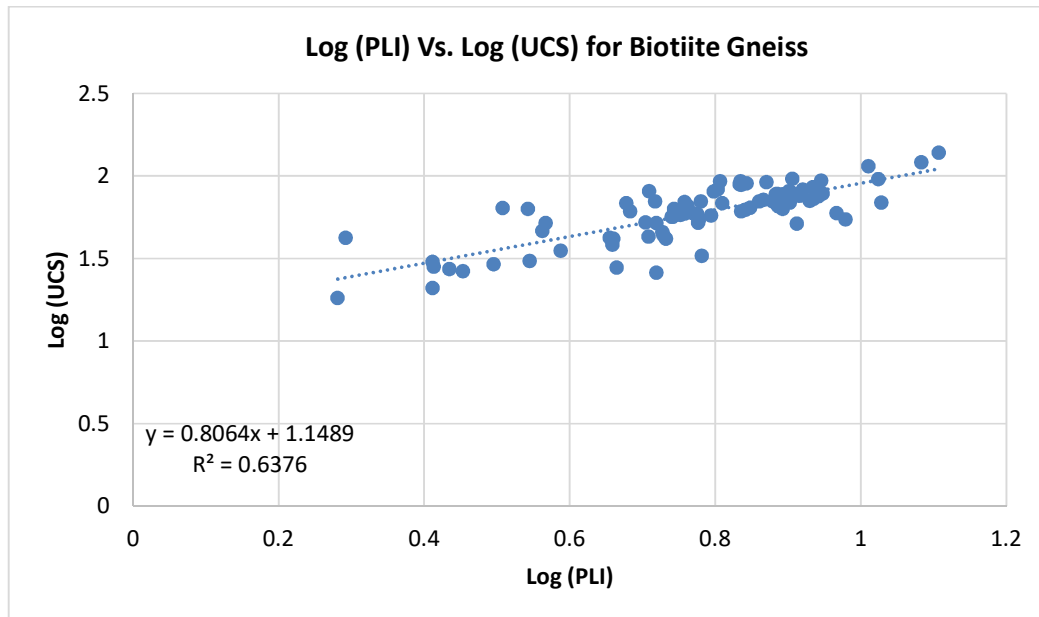

Figure 4.4: Relation between UCS value and $I_{s(50)}$ for Biotite Gneiss rock samples

The calculated coefficient of correlation (r) of the data set between Log (PLI) and Log (UCS) is 0.80 and this indicates a strong positive linear relationship between the two parameters. The coefficient of determination (R^2) of 0.64 which is >0.5 indicates a better fitness of the observations.

The correlation equation developed is as follows:

$$Y = 0.864X + 1.1489$$

$$\text{Log (UCS)} = 0.864\text{Log(PLI)} + 1.1489$$

$$\text{Log (UCS)} - 0.864\text{Log(PLI)} = 1.1489$$

$$\text{Log (UCS)} - \text{Log(PLI)}^{0.864} = 1.1489$$

$$\text{Log} \frac{(\text{UCS})}{(\text{PLI})^{0.864}} = 1.1489$$

$$\frac{(\text{UCS})}{(\text{PLI})^{0.864}} = 10^{1.1489}$$

$$(\text{UCS}) = 14.090 \times (\text{PLI})^{0.864}$$

The statistical analysis of the SG results obtained for Biotite Gneiss rock samples indicates the following:

1. Mean Specific Gravity = 2.77
2. Standard Deviation of the resulted values = 0.086

4.2.5. Garnet Biotite Gneiss rock samples

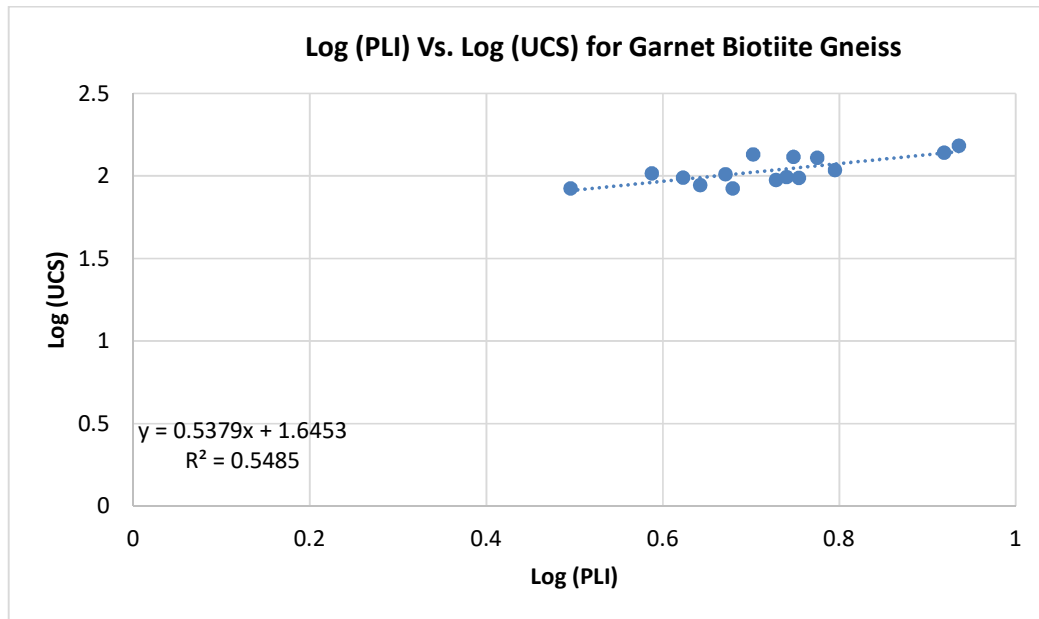

Figure 4.5: Relation between UCS value and $I_{s(50)}$ for Garnet Biotite Gneiss rock samples

The calculated coefficient of correlation (r) of the data set between Log (PLI) and Log (UCS) is 0.74 and this indicates a strong positive linear relationship between the two parameters. The coefficient of determination (R^2) of 0.55 which is >0.5 indicates a better fitness of the observations.

The correlation equation developed is as follows:

$$Y = 0.5379X + 1.6453$$

$$\text{Log (UCS)} = 0.5379\text{Log(PLI)} + 1.6453$$

$$\text{Log (UCS)} - 0.5379\text{Log(PLI)} = 1.6453$$

$$\text{Log (UCS)} - \text{Log(PLI)}^{0.5379} = 1.6453$$

$$\text{Log} \frac{(UCS)}{(PLI)^{0.5379}} = 1.6453$$

$$\frac{(UCS)}{(PLI)^{0.5379}} = 10^{1.6453}$$

$$(UCS) = 44.1876 \times (PLI)^{0.5379}$$

The statistical analysis of the SG results obtained for Garnet Biotite Gneiss rock samples indicates the following:

1. Mean Specific Gravity = 2.73
2. Standard Deviation of the resulted values = 0.107

4.3. Validation of the correlations established

The unique correlation established for different rock type was validated using a few sample test results. The relative accuracy between the predicted UCS value from the correlation and the actual test result obtained from a laboratory test was calculated and presented for each correlation.

4.3.1. Granulitic Gneiss rock samples

For the validation of the correlation established, two rock sample test results were used.

Correlation equation:

$$(UCS) = 10^{0.9236} \times (PLI)^{1.0198}$$

Sample test result 01: $PLI = 6.53MPa$, $UCS = 64.71MPa$

UCS value predicted from the correlation established = 56.84MPa

Deviation from the predicted value = $64.71 - 56.84 = +7.87MPa$

Deviation as a percentage = $\frac{+7.87}{56.84} \times 100 = +13.85\%$

Sample test result 02: $PLI = 8.10MPa$, $UCS = 70.20MPa$

UCS value predicted from the correlation established = 70.81MPa

Deviation from the predicted value = $70.20 - 70.81 = -0.61MPa$

Deviation as a percentage = $\frac{-0.61}{70.81} \times 100 = -0.86\%$

Table 4.7: Deviation of UCS from predicted value for Granulitic Gneiss rock

Validation sample no.	PLI (test)	UCS (test)	UCS (predicted)	Deviation of test UCS from predicted UCS
01	6.53MPa	64.71MPa	56.84MPa	+13.84%
02	8.10MPa	70.20MPa	70.81MPa	-0.86%

4.3.2. Garnet Granulite rock samples

For the validation of the correlation established, five rock sample test results were used.

Correlation equation:

$$(UCS) = 10^{1.1081} \times (PLI)^{0.7394}$$

Sample test result 01: $PLI = 9.96MPa$, $UCS = 78.25MPa$

UCS value predicted from the correlation established = 70.18MPa

Deviation from the predicted value = $78.25 - 70.18 = +8.07MPa$

Deviation as a percentage = $\frac{+8.07}{70.18} \times 100 = + 11.50\%$

Sample test result 02: $PLI = 14.10MPa$, $UCS = 102.25MPa$

UCS value predicted from the correlation established = 90.75MPa

Deviation from the predicted value = $102.25 - 90.75 = +11.5MPa$

Deviation as a percentage = $\frac{+11.5}{90.75} \times 100 = + 12.67\%$

Sample test result 03: $PLI = 8.02MPa$, $UCS = 67.93MPa$

UCS value predicted from the correlation established = 59.79MPa

Deviation from the predicted value = $67.93 - 59.79 = +8.14MPa$

Deviation as a percentage = $\frac{+8.14}{59.79} \times 100 = + 13.61\%$

Sample test result 04: $PLI = 6.80MPa$, $UCS = 64.27MPa$

UCS value predicted from the correlation established = 52.92MPa

Deviation from the predicted value = $64.27 - 52.92 = +11.35MPa$

Deviation as a percentage = $\frac{+11.35}{52.92} \times 100 = + 21.45\%$

Sample test result 05: $PLI = 7.48MPa$, $UCS = 69.23MPa$

UCS value predicted from the correlation established = 56.79MPa

Deviation from the predicted value = $69.23 - 56.79 = +12.44MPa$

Deviation as a percentage = $\frac{+12.44}{56.79} \times 100 = + 21.91\%$

Table 4.8: Deviation of UCS from predicted value for Garnet Granulitic rock

Validation sample no.	PLI (test)	UCS (test)	UCS (predicted)	Deviation of test UCS from predicted UCS
01	9.96MPa	78.25MPa	70.18MPa	+11.50%
02	14.10MPa	102.25MPa	90.75MPa	+12.67%
03	8.02MPa	67.93MPa	59.79MPa	+13.61%
04	6.80MPa	64.27MPa	52.92MPa	+21.45%
05	7.48MPa	69.23MPa	56.79MPa	+21.91%

4.3.3. Charnokitic Gneiss rock samples

For the validation of the correlation established, two rock sample test results were used.

Correlation equation:

$$(UCS) = 10^{1.1851} \times (PLI)^{0.7628}$$

Sample test result 01: PLI = 8.39MPa, UCS = 85.5MPa

UCS value predicted from the correlation established = 77.58MPa

Deviation from the predicted value = 85.5-77.58 = +7.92MPa

Deviation as a percentage = $\frac{+7.92}{77.58} \times 100 = + 10.21\%$

Sample test result 02: PLI = 6.76, UCS = 70.25MPa

UCS value predicted from the correlation established = 65.79MPa

Deviation from the predicted value = 70.25-65.79 = +4.46MPa

Deviation as a percentage = $\frac{+4.46}{65.79} \times 100 = + 6.78\%$

Table 4.9: Deviation of UCS from predicted value for Charnokitic Gneiss rock

Validation sample no.	PLI (test)	UCS (test)	UCS (predicted)	Deviation of test UCS from predicted UCS
01	8.39MPa	85.5MPa	77.58MPa	+10.21%
02	6.76MPa	70.25MPa	65.79MPa	+6.78%

4.3.4. Biotite Gneiss rock samples

For the validation of the correlation established, eight rock sample test results were used.

Correlation equation:

$$(UCS) = 10^{1.1489} \times (PLI)^{0.864}$$

Sample test result 01: $PLI = 4.88MPa$, $UCS = 50.21MPa$

UCS value predicted from the correlation established = 55.42MPa

Deviation from the predicted value = $50.21 - 55.42 = -5.21MPa$

$$\text{Deviation as a percentage} = \frac{-5.21}{55.42} \times 100 = -9.40\%$$

Sample test result 02: $PLI = 2.42MPa$, $UCS = 31.19MPa$

UCS value predicted from the correlation established = 30.24MPa

Deviation from the predicted value = $31.19 - 30.24 = +0.95MPa$

$$\text{Deviation as a percentage} = \frac{+0.95}{30.24} \times 100 = +3.14\%$$

Sample test result 03: $PLI = 2.58MPa$, $UCS = 25.25MPa$

UCS value predicted from the correlation established = 31.96MPa

Deviation from the predicted value = $25.25 - 31.96 = -6.71MPa$

$$\text{Deviation as a percentage} = \frac{-6.71}{31.96} \times 100 = -20.99\%$$

Sample test result 04: $PLI = 2.32MPa$, $UCS = 34.65MPa$

UCS value predicted from the correlation established = 29.15MPa

Deviation from the predicted value = $34.65 - 29.15 = +5.5MPa$

$$\text{Deviation as a percentage} = \frac{+5.5}{29.15} \times 100 = +18.87\%$$

Sample test result 05: $PLI = 5.37MPa$, $UCS = 52.26MPa$

UCS value predicted from the correlation established = 60.20MPa

Deviation from the predicted value = $52.26 - 60.20 = -7.94MPa$

$$\text{Deviation as a percentage} = \frac{-7.94}{60.20} \times 100 = -13.19\%$$

Sample test result 06: $PLI = 5.22\text{MPa}$, $UCS = 53.32\text{MPa}$

UCS value predicted from the correlation established = 58.74MPa

Deviation from the predicted value = $53.32 - 58.74 = -5.42\text{MPa}$

Deviation as a percentage = $\frac{-5.42}{58.74} \times 100 = -9.23\%$

Sample test result 07: $PLI = 3.25\text{MPa}$, $UCS = 35.59\text{MPa}$

UCS value predicted from the correlation established = 39.01MPa

Deviation from the predicted value = $35.59 - 39.01 = -3.42\text{MPa}$

Deviation as a percentage = $\frac{-3.42}{39.01} \times 100 = -8.77\%$

Sample test result 08: $PLI = 8.12\text{MPa}$, $UCS = 83.95\text{MPa}$

UCS value predicted from the correlation established = 86.05MPa

Deviation from the predicted value = $83.95 - 86.05 = -2.10\text{MPa}$

Deviation as a percentage = $\frac{-2.10}{86.05} \times 100 = -2.44\%$

Table 4.10: Deviation of UCS from predicted value for Biotite Gneiss rock

Validation sample no.	PLI (test)	UCS (test)	UCS (predicted)	Deviation of test UCS from predicted UCS
01	4.88MPa	50.21MPa	55.42MPa	-9.40%
02	2.42MPa	31.19MPa	30.24MPa	+3.14%
03	2.58MPa	25.25MPa	31.96MPa	-20.99%
04	2.32MPa	34.65MPa	29.15MPa	+18.87%
05	5.37MPa	52.26MPa	60.20MPa	-13.19%
06	5.22MPa	53.32MPa	58.74MPa	-9.23%
07	3.25MPa	35.59MPa	39.01MPa	-8.77%
08	8.12MPa	83.95MPa	86.05MPa	-2.44%

4.3.5. Garnet Biotite Gneiss rock samples

For the validation of the correlation established, five rock sample test results were used.

Correlation equation:

$$(UCS) = 10^{1.6453} \times (PLI)^{0.5379}$$

Sample test result 01: $PLI = 7.20MPa$, $UCS = 160.88MPa$

UCS value predicted from the correlation established = 127.78MPa

Deviation from the predicted value = $160.88 - 127.78 = + 33.10MPa$

$$\text{Deviation as a percentage} = \frac{+33.1}{127.78} \times 100 = + 25.90\%$$

Sample test result 02: $PLI = 2.44MPa$, $UCS = 59.17MPa$

UCS value predicted from the correlation established = 71.40MPa

Deviation from the predicted value = $59.17 - 71.40 = - 12.23MPa$

$$\text{Deviation as a percentage} = \frac{-12.23}{71.40} \times 100 = - 17.13\%$$

Sample test result 03: $PLI = 5.88MPa$, $UCS = 93.17MPa$

UCS value predicted from the correlation established = 114.59MPa

Deviation from the predicted value = $93.17 - 114.59 = - 21.42MPa$

$$\text{Deviation as a percentage} = \frac{-21.42}{114.59} \times 100 = - 18.69\%$$

Sample test result 04: $PLI = 3.66MPa$, $UCS = 90.21MPa$

UCS value predicted from the correlation established = 88.80MPa

Deviation from the predicted value = $90.21 - 88.80 = +1.41MPa$

$$\text{Deviation as a percentage} = \frac{+1.41}{88.80} \times 100 = + 1.59\%$$

Sample test result 05: $PLI = 2.03MPa$, $UCS = 70.04MPa$

UCS value predicted from the correlation established = 64.67MPa

Deviation from the predicted value = $70.04 - 64.67 = + 5.37MPa$

$$\text{Deviation as a percentage} = \frac{+5.37}{64.67} \times 100 = + 8.30\%$$

Table 4.11: Deviation of UCS from predicted value for Garnet Biotite Gneiss rock

Validation sample no.	PLI (test)	UCS (test)	UCS (predicted)	Deviation of test UCS from predicted UCS
01	7.20MPa	160.88MPa	127.78MPa	+25.90%
02	2.44MPa	59.17MPa	71.40MPa	-17.13%
03	5.88MPa	93.17MPa	114.59MPa	-18.69%
04	3.66MPa	90.21MPa	88.80MPa	+1.59%
05	2.03MPa	70.04MPa	64.67MPa	+8.30%

CHAPTER 5: CONCLUSIONS AND RECOMMENDATIONS

5.1. Conclusions

The test results of 137 numbers of different rock samples were analyzed and based on the type of the rock, different correlations were established between the PLI and UCS values. Mainly five different rock types were identified and for each rock type, a best fit linear regression line between the log values of PLI and UCS were found. Log values of PLI and UCS had better correlation than their natural values. All the correlations showed a correlation coefficient of more than 0.7 and coefficient of determination of more than 0.5. These statistical parameters prove that the established correlations are strong positive relationships.

Although, the correlations are different from one rock type to the other, the variation in the correlations is limited in the rock types; Granulitic Gneiss, Garnet Granulite, Charnokitic Gneiss and Biotite Gneiss.

All the correlations were validated from sample test results and it showed that, all the correlations predict the UCS values with not more than $\pm 26\%$ deviation.

Since the SG value range is very narrow, a correlation with SG to UCS or PLI was not significant. But, as a cross check for the rock type, an average value for SG of each type of rock was determined and reported.

Figures 5.1 shows the lines of best fit for all the five types of rock analyzed in the research.

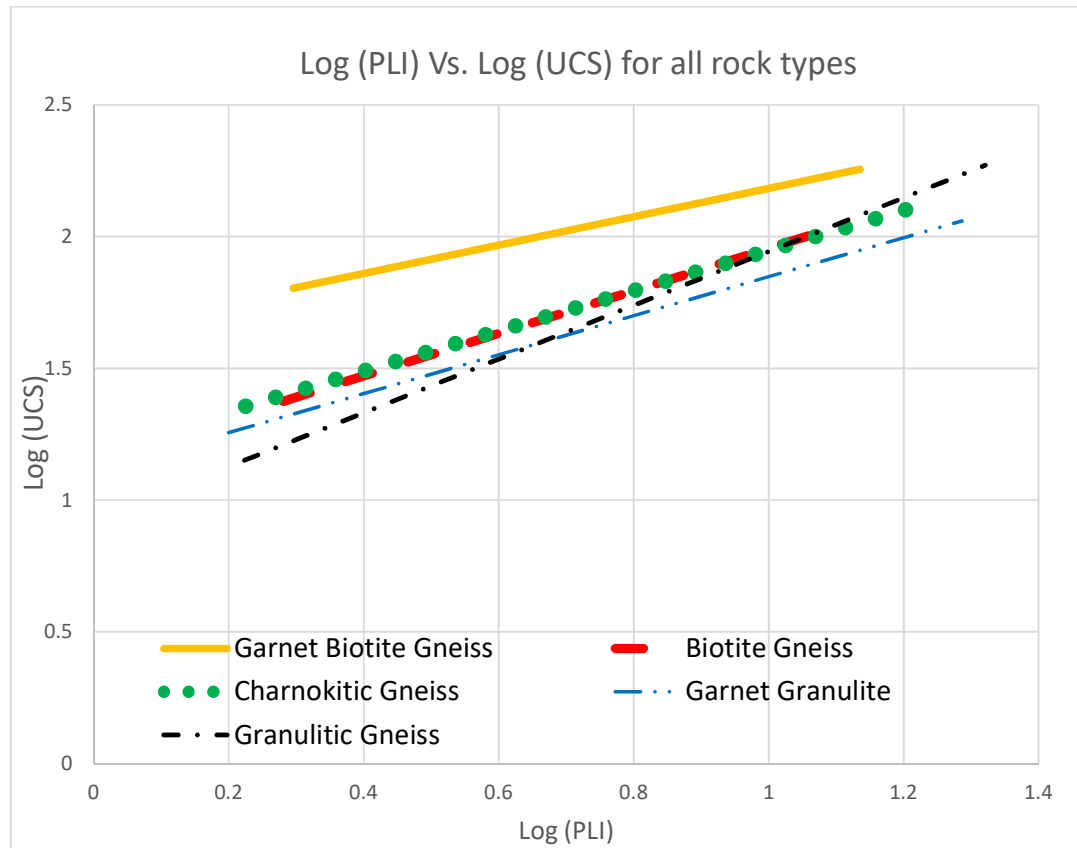

Figure 5.1: Relation between UCS value and $I_{s(50)}$ for all rock types analyzed

As it can be seen from the figure 5.1 above, a common relation can be developed for the rock types; Biotite Gneiss, Charnokitic Gneiss, Garnet Granulite and Granulitic Gneiss. The common correlation for these four rock types is denoted as Grouped Rocks in the Figure 5.2. A comparison done among the other correlations developed by other researches is presented in the Figure 5.2.

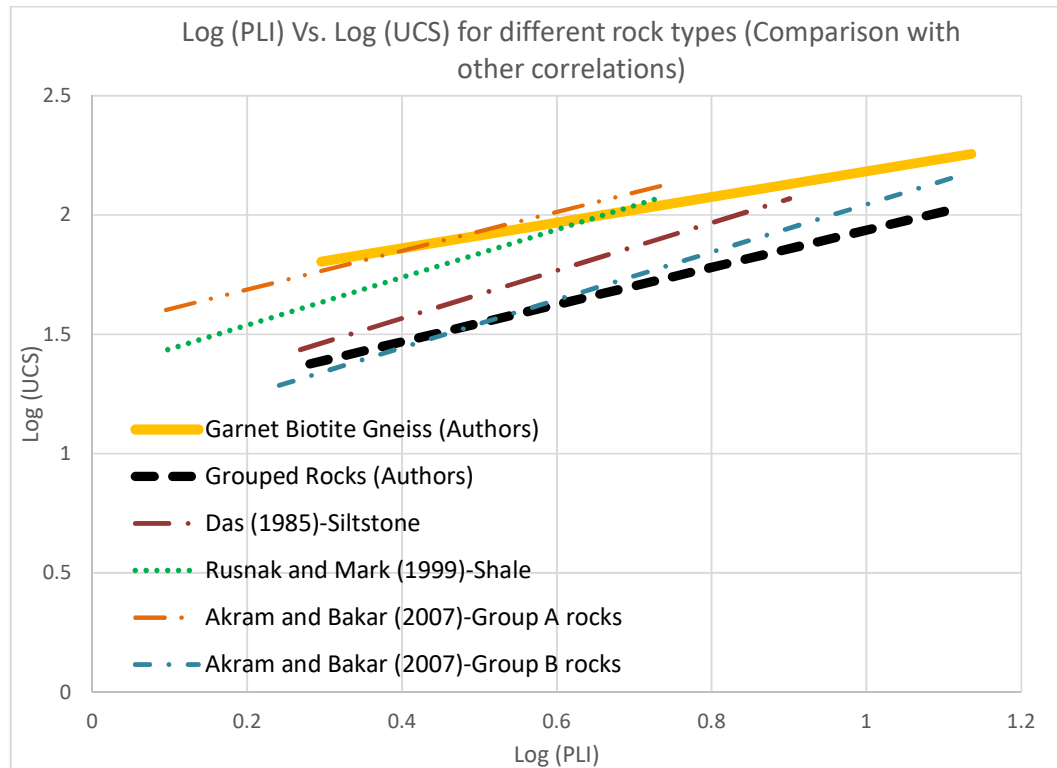

Figure 5.2: Comparison of the correlations established among UCS value and $I_{s(50)}$ by other researchers

[Das (1985) and Rusnak and Mark (1999) are taken from Correlation between uniaxial strength and point load index of rocks, Mahtab et al. (2016)]

5.2. Recommendations

The linear correlations established and validated for the log of PLI and UCS of five different rock types, namely; Granulitic Gneiss, Garnet Granulite, Charnokitic Gneiss, Biotite Gneiss and Garnet Biotite Gneiss are recommended to predict UCS value from the PLI value. The SG value determined can be used as a guide to support the grouping of the rock sample of interest to a certain extent in addition to its visual identification. The correlations can be further improved by integrating new UCS and PLI data in to the correlation equations when available in future.

As a further study, it is recommended to analyze different correlations between rock types while addressing variations in the mineral content presence in the same rock type.

REFERENCES

American Society for Testing of Materials (ASTM) (1977) Standard Test Method for Direct Tensile Strength of Intact Rock Core Specimens, ASTM Designation, D 2936-71: ASTM Standards Part 19, 381-388.

American Society for Testing of Materials (ASTM)(1977) Standard Test method for Unconfined Compressive strength and Intact Rock Core Specimen, ASTM Designation, D 2938-71a, ASTM Standards Part 19: 389-390.

Gupta S.C. and Kapoor V.K. (2002) Fundamentals of mathematical statistics, New Delhi, Sultan Chand & Sons.

International Society for Rock Mechanics (ISRM) (1977) Suggested Method for Determining Tensile Strength of Rock materials, ISRM Committee on Laboratory and Field Tests, Int. Jour. Rock Mech. Min. Sci. & Geomech. Abstr. 15(3): 99-103.

International Society for Rock Mechanics (ISRM) (1985) Suggested Method for Determining Point Load Strength, ISRM Committee on Laboratory and Field Tests, Int. Jour. of Rock Mech, Min. Sci. & Geomech., 22 (2): 53-60.

Jayawardena, U.de S. (2001) A Study on the engineering properties of Sri Lankan Rocks, Jour. of the Inst. of Eng., Sri Lanka xxxiv: p 7-21.



Vutukuri V.S, and Katsuyama, K. (1994) Introduction to Rock Mechanics. Tokyo, Industrial Publishing & Consulting, Inc.

Mahtab et al. (2016) Correlation between uniaxial strength and point load index of rocks, The 15th Asian Regional Conference on Soil Mechanics and Geotechnical Engineering. https://www.jstage.jst.go.jp/article/jgssp/2_IRN-08/_pdf

Akram and Bakar (2007) Correlation between Uniaxial Compressive Strength and Point Load Index for Salt-Range Rocks. Pak. J. Engg. & Appl. Sci. Vol. 1 July 2007

Statisticshowto.com; <https://www.statisticshowto.datasciencecentral.com/probability-and-statistics/coefficient-of-determination-r-squared>

Annex A: Sample UCS Test reports for Granulitic Gneiss Rock
specimens tested

	UNCONFINED COMPRESSIVE STRENGTH TEST ON INTACT ROCK CORE SPECIMENS TEST METHOD -ASTM D 2938		Test Format No:	ELS-ML-36
			Revision No.	00
Project data:				
Client:	J. M. S. T. W. Jayasinghe			
Project :	MSc. Research Project			
Sample data:				
Sample description:	Rock (Granulitic Gneiss)	Lab ref. No:	R/0001	
Sample No.	119	Date of Testing:	17.05.2019	
Source:	-	Date of Report:	18.05.2019	
Test Data:				
Specimen No.:			01	
Sampling Depth(m)			-	
Specimen Diameter	cm		5.46	
Specimen Length	cm		10.96	
Sectional area of the Specimen	cm ²		23.41	
Volume of Specimen	cm ³		256.70	
Weight of specimen	g		741.0	
Unit Weight	g/cm ³		2.89	
Failure Load	kN		144.0	
Measured Compressive Strength	N/mm ²		61.50	
Correction Factor for height to diameter ratio			1.000	
Corrected Compressive Strength	N/mm ²		61.53	
Mode of Failure				

ENGINEERING & LABORATORY SERVICES (PVT) LTD

62/3, Neelammahara Road, Katuwawala, Boralesgamuwa, Sri Lanka.

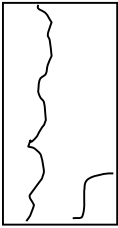

Telephone : 0094 011 4309494/ 2517037 / 2517365, Fax : 0094 01 2509806, E-Mail : els@lanka.com.

	UNCONFINED COMPRESSIVE STRENGTH TEST ON INTACT ROCK CORE SPECIMENS		Test Format No:	ELS-ML-36
	TEST METHOD -ASTM D 2938		Revision No.	00
Project data:				
Client:	J. M. S. T. W. Jayasinghe			
Project :	MSc. Research Project			
Sample data:				
Sample description:	Rock (Granulitic Gneiss)	Lab ref. No:	R/0001	
Sample No.	120	Date of Testing:	17.05.2019	
Source:	-	Date of Report:	18.05.2019	
Test Data:				
Specimen No.:			01	
Sampling Depth(m)			-	
Specimen Diameter	cm		5.44	
Specimen Length	cm		10.95	
Sectional area of the Specimen	cm ²		23.21	
Volume of Specimen	cm ³		254.12	
Weight of specimen	g		715.0	
Unit Weight	g/cm ³		2.81	
Failure Load	kN		155.9	
Measured Compressive Strength	N/mm ²		67.16	
Correction Factor for height to diameter ratio			0.999	
Corrected Compressive Strength	N/mm ²		67.21	
Mode of Failure				

ENGINEERING & LABORATORY SERVICES (PVT) LTD

62/3, Neelammahara Road, Katuwawala, Boralesgamuwa, Sri Lanka.



Telephone : 0094 011 4309494/ 2517037 / 2517365, Fax : 0094 01 2509806, E-Mail : els@lanka.com.

	UNCONFINED COMPRESSIVE STRENGTH TEST ON INTACT ROCK CORE SPECIMENS		Test Format No:	ELS-ML-36
	TEST METHOD -ASTM D 2938		Revision No.	00
Project data:				
Client:	J. M. S. T. W. Jayasinghe			
Project :	MSc. Research Project			
Sample data:				
Sample description:	Rock (Granulitic Gneiss)	Lab ref. No:	R/0001	
Sample No.	121	Date of Testing:	17.05.2019	
Source:	-	Date of Report:	18.05.2019	
Test Data:				
Specimen No.:			01	
Sampling Depth(m)			-	
Specimen Diameter	cm		5.44	
Specimen Length	cm		10.09	
Sectional area of the Specimen	cm ²		23.21	
Volume of Specimen	cm ³		234.16	
Weight of specimen	g		746.0	
Unit Weight	g/cm ³		3.19	
Failure Load	kN		113.9	
Measured Compressive Strength	N/mm ²		49.06	
Correction Factor for height to diameter ratio			1.009	
Corrected Compressive Strength	N/mm ²		48.61	
Mode of Failure				

ENGINEERING & LABORATORY SERVICES (PVT) LTD

62/3, Neelammahara Road, Katuwawala, Boralesgamuwa, Sri Lanka.

Telephone : 0094 011 4309494/ 2517037 / 2517365, Fax : 0094 01 2509806, E-Mail : els@lanka.com.

	UNCONFINED COMPRESSIVE STRENGTH TEST ON INTACT ROCK CORE SPECIMENS		Test Format No:	ELS-ML-36
	TEST METHOD -ASTM D 2938		Revision No.	00
Project data:				
Client:	J. M. S. T. W. Jayasinghe			
Project :	MSc. Research Project			
Sample data:				
Sample description:	Rock (Granulitic Gneiss)	Lab ref. No:	R/0001	
Sample No.	122	Date of Testing:	17.05.2019	
Source:	-	Date of Report:	18.05.2019	
Test Data:				
Specimen No.:			01	
Sampling Depth(m)			-	
Specimen Diameter	cm		5.43	
Specimen Length	cm		10.76	
Sectional area of the Specimen	cm ²		23.13	
Volume of Specimen	cm ³		248.95	
Weight of specimen	g		690.0	
Unit Weight	g/cm ³		2.77	
Failure Load	kN		162.1	
Measured Compressive Strength	N/mm ²		70.09	
Correction Factor for height to diameter ratio			1.001	
Corrected Compressive Strength	N/mm ²		70.01	
Mode of Failure				

ENGINEERING & LABORATORY SERVICES (PVT) LTD

62/3, Neelammahara Road, Katuwawala, Boralesgamuwa, Sri Lanka.

Telephone : 0094 011 4309494/ 2517037 / 2517365, Fax : 0094 01 2509806, E-Mail : els@lanka.com.

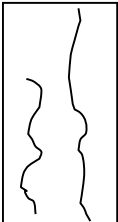
	UNCONFINED COMPRESSIVE STRENGTH TEST ON INTACT ROCK CORE SPECIMENS		Test Format No:	ELS-ML-36
	TEST METHOD -ASTM D 2938		Revision No.	00
Project data:				
Client:	J. M. S. T. W. Jayasinghe			
Project :	MSc. Research Project			
Sample data:				
Sample description:	Rock (Granulitic Gneiss)	Lab ref. No:	R/0001	
Sample No.	123	Date of Testing:	17.05.2019	
Source:	-	Date of Report:	18.05.2019	
Test Data:				
Specimen No.:			01	
Sampling Depth(m)			-	
Specimen Diameter	cm		5.43	
Specimen Length	cm		10.64	
Sectional area of the Specimen	cm ²		23.13	
Volume of Specimen	cm ³		246.02	
Weight of specimen	g		698.0	
Unit Weight	g/cm ³		2.84	
Failure Load	kN		122.4	
Measured Compressive Strength	N/mm ²		52.92	
Correction Factor for height to diameter ratio			1.002	
Corrected Compressive Strength	N/mm ²		52.79	
Mode of Failure				

ENGINEERING & LABORATORY SERVICES (PVT) LTD

62/3, Neelammahara Road, Katuwawala, Boralesgamuwa, Sri Lanka.

Telephone : 0094 011 4309494/ 2517037 / 2517365, Fax : 0094 01 2509806, E-Mail : els@lanka.com.

Annex B: Sample PLI Test reports for Granulitic Gneiss Rock specimens
tested



**POINT LOAD TEST
ASTM D 5731-02**

Test Format No: ELS-ML-35

Revision No. 00

Project data:

Client: J. M. S. T. W. Jayasinghe

Project: MSc. Research Project

Sample data:

Sample Description: Rock (Granulitic Gneiss)

Sample No.: 119

Depth: -

Lab Ref.No. R/0001

Job No: -

Date of Testing: 17.05.2019

Date of Report: 18.05.2019

Test data:

Speciman number.		01
Sample diameter	mm	54.40
Sectional Area of the Sample	mm ²	2324.28
Failure Load	kN	19.43
Point Load index	N/mm ²	6.566
Size correction factor		1.039
Size corrected point load strength index, $I_{sp(50)}$	N/mm ²	6.82
Average of Size corrected point load strength index, $I_{sp(50)}$	N/mm ²	-

Note: Only one Specimen was tested as per the request.

ENGINEERING & LABORATORY SERVICES (PVT) LTD

62/3, Neelammahara Road, Katuwawala, Boralesgamuwa, Sri Lanka.

Telephone : 0094 01 517037 / 517365 / 519727, Fax : 0094 01 509806, E-Mail : els@lanka.com.



**POINT LOAD TEST
ASTM D 5731-02**

Test Format No: ELS-ML-35

Revision No. 00

Project data:

Client: J. M. S. T. W. Jayasinghe

Project: MSc. Research Project

Sample data:

Sample Description: Rock (Granulitic Gneiss)

Sample No.: 120

Depth: -

Lab Ref.No. R/0001

Job No: -

Date of Testing: 17.05.2019

Date of Report: 18.05.2019

Test data:

Speciman number.		01
Sample diameter	mm	54.60
Sectional Area of the Sample	mm ²	2341.40
Failure Load	kN	22.17
Point Load index	N/mm ²	7.437
Size correction factor		1.040
Size corrected point load strength index, $I_{sp(50)}$	N/mm ²	7.74
Average of Size corrected point load strength index, $I_{sp(50)}$	N/mm ²	-

Note: Only one Specimen was tested as per the request.

ENGINEERING & LABORATORY SERVICES (PVT) LTD

62/3, Neelammahara Road, Katuwawala, Boralesgamuwa, Sri Lanka.

Telephone : 0094 01 517037 / 517365 / 519727, Fax : 0094 01 509806, E-Mail : els@lanka.com.



**POINT LOAD TEST
ASTM D 5731-02**

Test Format No: ELS-ML-35
Revision No. 00

Project data:

Client: J. M. S. T. W. Jayasinghe
Project: MSc. Research Project

Sample data:

Sample Description: Rock (Granulitic Gneiss) Lab Ref.No. R/0001
Sample No.: 121 Job No: -
Depth: - Date of Testing: 17.05.2019
Date of Report: 18.05.2019

Test data:

Speciman number.		01
Sample diameter	mm	54.60
Sectional Area of the Sample	mm ²	2341.40
Failure Load	kN	15.15
Point Load index	N/mm ²	5.082
Size correction factor		1.040
Size corrected point load strength index, $I_{sp(50)}$	N/mm ²	5.29
Average of Size corrected point load strength index, $I_{sp(50)}$	N/mm ²	-

Note: Only one Specimen was tested as per the request.

ENGINEERING & LABORATORY SERVICES (PVT) LTD

62/3, Neelammahara Road, Katuwawala, Boralesgamuwa, Sri Lanka.
Telephone : 0094 01 517037 / 517365 / 519727, Fax : 0094 01 509806, E-Mail : els@lanka.com.



**POINT LOAD TEST
ASTM D 5731-02**

Test Format No: ELS-ML-35

Revision No. 00

Project data:

Client: J. M. S. T. W. Jayasinghe

Project: MSc. Research Project

Sample data:

Sample Description: Rock (Granulitic Gneiss)

Sample No.: 122

Depth: -

Lab Ref.No. R/0001

Job No: -

Date of Testing: 17.05.2019

Date of Report: 18.05.2019

Test data:

Speciman number.		01
Sample diameter	mm	54.50
Sectional Area of the Sample	mm ²	2332.83
Failure Load	kN	21.18
Point Load index	N/mm ²	7.131
Size correction factor		1.040
Size corrected point load strength index, $I_{sp(50)}$	N/mm ²	7.41
Average of Size corrected point load strength index, $I_{sp(50)}$	N/mm ²	-

Note: Only one Specimen was tested as per the request.

ENGINEERING & LABORATORY SERVICES (PVT) LTD

62/3, Neelammahara Road, Katuwawala, Boralesgamuwa, Sri Lanka.

Telephone : 0094 01 517037 / 517365 / 519727, Fax : 0094 01 509806, E-Mail : els@lanka.com.



**POINT LOAD TEST
ASTM D 5731-02**

Test Format No: ELS-ML-35

Revision No. 00

Project data:

Client: J. M. S. T. W. Jayasinghe

Project: MSc. Research Project

Sample data:

Sample Description: Rock (Granulitic Gneiss)

Sample No.: 123

Depth: -

Lab Ref.No. R/0001

Job No: -

Date of Testing: 17.05.2019

Date of Report: 18.05.2019

Test data:

Speciman number.		01
Sample diameter	mm	53.10
Sectional Area of the Sample	mm ²	2214.52
Failure Load	kN	16.03
Point Load index	N/mm ²	5.685
Size correction factor		1.027
Size corrected point load strength index, $I_{sp(50)}$	N/mm ²	5.84
Average of Size corrected point load strength index, $I_{sp(50)}$	N/mm ²	-

Note: Only one Specimen was tested as per the request.

ENGINEERING & LABORATORY SERVICES (PVT) LTD

62/3, Neelammahara Road, Katuwawala, Boralesgamuwa, Sri Lanka.

Telephone : 0094 01 517037 / 517365 / 519727, Fax : 0094 01 509806, E-Mail : els@lanka.com.

Annex C: Sample SG Test reports for Granulitic Gneiss Rock specimens
tested



**SPECIFIC GRAVITY & WATER ABSORPTION OF
COARSE AGGREGATE
TEST METHOD - BS 812: PART 2**

Test Format No: ELS-ML-18

Revision No. 00

Project data:

Client: J. M. S. T. W. Jayasinghe

Project: MSc. Research Project

Sample data:

Sample Description: Rock (Granulitic Gneiss)

Lab Ref. No. R/0001

Sample No.: 119

Date of testing: 17.05.2019

Location: -

Date of Report: 18.05.2019

Test Data:

Specimen No.:	1
Weight of oven Dried Sample in air (g)	547.7
Weight of SSD Sample in air (g)	549.7
Weight of SSD Sample in water (g)	342.5
Relative Density on SSD Basis	2.653
Relative Density on an Oven Dried Basis	2.643
Apparent Relative Density	2.669
Water Absorption (% of Dry Basis)	0.37

Apparent Relative Density = 2.67

Water Absorption (% of Dry Basis) = 0.37



Note:* This report refers specially to the sample analyzed.

ENGINEERING & LABORATORY SERVICES (PVT) LTD

62/3, Neelammahara Road, Katuwawala, Boralessgamuwa, Sri Lanka.

Telephone : 0094 011 4309494/ 2517037 / 2517365, Fax : 0094 01 2509806, E-Mail : els@elslanka.com.

Annex D: Sample UCS Test reports for Garnet Granulite Rock specimens
tested

	UNCONFINED COMPRESSIVE STRENGTH TEST ON INTACT ROCK CORE SPECIMENS		Test Format No:	ELS-ML-36
	TEST METHOD -ASTM D 2938		Revision No.	00
Project data:				
Client:	J. M. S. T. W. Jayasinghe			
Project :	MSc. Research Project			
Sample data:				
Sample description:	Rock (Granet Granulite)	Lab ref. No:	R/0001	
Sample No.	83	Date of Testing:	16.05.2019	
Source:	-	Date of Report:	17.05.2019	
Test Data:				
Specimen No.:			01	
Sampling Depth(m)			-	
Specimen Diameter		cm	5.47	
Specimen Length		cm	10.56	
Sectional area of the Specimen		cm ²	23.47	
Volume of Specimen		cm ³	247.86	
Weight of specimen		g	705.0	
Unit Weight		g/cm ³	2.84	
Failure Load		kN	187.0	
Measured Compressive Strength		N/mm ²	79.69	
Correction Factor for height to diameter ratio			1.004	
Corrected Compressive Strength		N/mm ²	79.35	
Mode of Failure				

ENGINEERING & LABORATORY SERVICES (PVT) LTD

62/3, Neelammahara Road, Katuwawala, Boralesgamuwa, Sri Lanka.

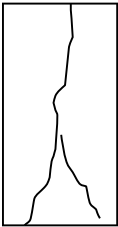

Telephone : 0094 011 4309494/ 2517037 / 2517365, Fax : 0094 01 2509806, E-Mail : els@lanka.com.

	UNCONFINED COMPRESSIVE STRENGTH TEST ON INTACT ROCK CORE SPECIMENS		Test Format No:	ELS-ML-36
	TEST METHOD -ASTM D 2938		Revision No.	00
Project data:				
Client:	J. M. S. T. W. Jayasinghe			
Project :	MSc. Research Project			
Sample data:				
Sample description:	Rock (Granet Granulite)	Lab ref. No:	R/0001	
Sample No.	87	Date of Testing:	16.05.2019	
Source:	-	Date of Report:	17.05.2019	
Test Data:				
Specimen No.:			01	
Sampling Depth(m)			-	
Specimen Diameter	cm		5.45	
Specimen Length	cm		10.55	
Sectional area of the Specimen	cm ²		23.30	
Volume of Specimen	cm ³		245.74	
Weight of specimen	g		707.0	
Unit Weight	g/cm ³		2.88	
Failure Load	kN		154.4	
Measured Compressive Strength	N/mm ²		66.27	
Correction Factor for height to diameter ratio			1.004	
Corrected Compressive Strength	N/mm ²		66.01	
Mode of Failure				

ENGINEERING & LABORATORY SERVICES (PVT) LTD

62/3, Neelammahara Road, Katuwawala, Boralesgamuwa, Sri Lanka.

Telephone : 0094 011 4309494/ 2517037 / 2517365, Fax : 0094 01 2509806, E-Mail : els@lanka.com.

	UNCONFINED COMPRESSIVE STRENGTH TEST ON INTACT ROCK CORE SPECIMENS TEST METHOD -ASTM D 2938		Test Format No:	ELS-ML-36
			Revision No.	00
Project data:				
Client:	J. M. S. T. W. Jayasinghe			
Project :	MSc. Research Project			
Sample data:				
Sample description:	Rock (Granet Granulite)	Lab ref. No:	R/0001	
Sample No.	88	Date of Testing:	16.05.2019	
Source:	-	Date of Report:	17.05.2019	
Test Data:				
Specimen No.:			01	
Sampling Depth(m)			-	
Specimen Diameter	cm		5.47	
Specimen Length	cm		10.56	
Sectional area of the Specimen	cm ²		23.47	
Volume of Specimen	cm ³		247.86	
Weight of specimen	g		705.0	
Unit Weight	g/cm ³		2.84	
Failure Load	kN		159.3	
Measured Compressive Strength	N/mm ²		67.87	
Correction Factor for height to diameter ratio			1.004	
Corrected Compressive Strength	N/mm ²		67.58	
Mode of Failure				

ENGINEERING & LABORATORY SERVICES (PVT) LTD

62/3, Neelammahara Road, Katuwawala, Boralesgamuwa, Sri Lanka.

Telephone : 0094 011 4309494/ 2517037 / 2517365, Fax : 0094 01 2509806, E-Mail : els@lanka.com.

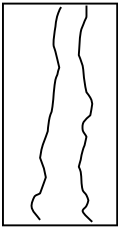
	UNCONFINED COMPRESSIVE STRENGTH TEST ON INTACT ROCK CORE SPECIMENS TEST METHOD -ASTM D 2938		Test Format No:	ELS-ML-36
			Revision No.	00
Project data:				
Client:	J. M. S. T. W. Jayasinghe			
Project :	MSc. Research Project			
Sample data:				
Sample description:	Rock (Granet Granulite)	Lab ref. No:	R/0001	
Sample No.	108	Date of Testing:	17.05.2019	
Source:	-	Date of Report:	18.05.2019	
Test Data:				
Specimen No.:			01	
Sampling Depth(m)			-	
Specimen Diameter	cm		5.46	
Specimen Length	cm		10.46	
Sectional area of the Specimen	cm ²		23.44	
Volume of Specimen	cm ³		245.21	
Weight of specimen	g		674.0	
Unit Weight	g/cm ³		2.75	
Failure Load	kN		144.2	
Measured Compressive Strength	N/mm ²		61.51	
Correction Factor for height to diameter ratio			1.005	
Corrected Compressive Strength	N/mm ²		61.18	
Mode of Failure				

ENGINEERING & LABORATORY SERVICES (PVT) LTD

62/3, Neelammahara Road, Katuwawala, Boralesgamuwa, Sri Lanka.

Telephone : 0094 011 4309494/ 2517037 / 2517365, Fax : 0094 01 2509806, E-Mail : els@lanka.com.

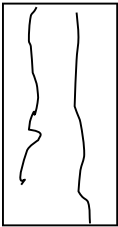
	UNCONFINED COMPRESSIVE STRENGTH TEST ON INTACT ROCK CORE SPECIMENS TEST METHOD -ASTM D 2938		Test Format No:	ELS-ML-36
			Revision No.	00
Project data:				
Client:	J. M. S. T. W. Jayasinghe			
Project :	MSc. Research Project			
Sample data:				
Sample description:	Rock (Granet Granulite)	Lab ref. No:	R/0001	
Sample No.	111	Date of Testing:	17.05.2019	
Source:	-	Date of Report:	18.05.2019	
Test Data:				
Specimen No.:			01	
Sampling Depth(m)			-	
Specimen Diameter	cm		5.46	
Specimen Length	cm		10.55	
Sectional area of the Specimen	cm ²		23.39	
Volume of Specimen	cm ³		246.79	
Weight of specimen	g		653.0	
Unit Weight	g/cm ³		2.65	
Failure Load	kN		145.6	
Measured Compressive Strength	N/mm ²		62.26	
Correction Factor for height to diameter ratio			1.004	
Corrected Compressive Strength	N/mm ²		62.01	
Mode of Failure				

ENGINEERING & LABORATORY SERVICES (PVT) LTD

62/3, Neelammahara Road, Katuwawala, Boralesgamuwa, Sri Lanka.

Telephone : 0094 011 4309494/ 2517037 / 2517365, Fax : 0094 01 2509806, E-Mail : els@lanka.com.

Annex E: Sample PLI Test reports for Garnet Granulite Rock specimens
tested



**POINT LOAD TEST
ASTM D 5731-02**

Test Format No: ELS-ML-35
Revision No. 00

Project data:

Client: J. M. S. T. W. Jayasinghe
Project: MSc. Research Project

Sample data:

Sample Description: Rock (Granet Granulite) Lab Ref.No. R/0001
Sample No.: 83 Job No: -
Depth: - Date of Testing: 16.05.2019
Date of Report: 17.05.2019

Test data:

Speciman number.		01
Sample diameter	mm	54.50
Sectional Area of the Sample	mm ²	2332.83
Failure Load	kN	26.14
Point Load index	N/mm ²	8.801
Size correction factor		1.040
Size corrected point load strength index, $f_{sp(50)}$	N/mm ²	9.15
Average of Size corrected point load strength index, $f_{sp(50)}$	N/mm ²	-

Note: Only one Specimen was tested as per the request.

ENGINEERING & LABORATORY SERVICES (PVT) LTD

62/3, Neelammahara Road, Katuwawala, Boralesgamuwa, Sri Lanka.
Telephone : 0094 01 517037 / 517365 / 519727, Fax : 0094 01 509806, E-Mail : els@lanka.com.



**POINT LOAD TEST
ASTM D 5731-02**

Test Format No: ELS-ML-35

Revision No. 00

Project data:

Client: J. M. S. T. W. Jayasinghe

Project: MSc. Research Project

Sample data:

Sample Description: Rock (Granet Granulite)

Lab Ref.No. R/0001

Sample No.: 87

Job No: -

Depth: -

Date of Testing: 16.05.2019

Date of Report: 17.05.2019

Test data:

Speciman number.		01
Sample diameter	mm	54.80
Sectional Area of the Sample	mm ²	2358.59
Failure Load	kN	24.08
Point Load index	N/mm ²	8.019
Size correction factor		1.042
Size corrected point load strength index, $I_{sp(50)}$	N/mm ²	8.36
Average of Size corrected point load strength index, $I_{sp(50)}$	N/mm ²	-

Note: Only one Specimen was tested as per the request.

ENGINEERING & LABORATORY SERVICES (PVT) LTD

62/3, Neelammahara Road, Katuwawala, Boralesgamuwa, Sri Lanka.

Telephone : 0094 01 517037 / 517365 / 519727, Fax : 0094 01 509806, E-Mail : els@lanka.com.



**POINT LOAD TEST
ASTM D 5731-02**

Test Format No: ELS-ML-35
Revision No. 00

Project data:

Client: J. M. S. T. W. Jayasinghe
Project: MSc. Research Project

Sample data:

Sample Description: Rock (Granet Granulite) Lab Ref.No. R/0001
Sample No.: 88 Job No: -
Depth: - Date of Testing: 16.05.2019
Date of Report: 17.05.2019

Test data:

Speciman number.		01
Sample diameter	mm	54.70
Sectional Area of the Sample	mm ²	2349.99
Failure Load	kN	24.36
Point Load index	N/mm ²	8.141
Size correction factor		1.041
Size corrected point load strength index, $f_{sp(50)}$	N/mm ²	8.48
Average of Size corrected point load strength index, $f_{sp(50)}$	N/mm ²	-

Note: Only one Specimen was tested as per the request.

ENGINEERING & LABORATORY SERVICES (PVT) LTD

62/3, Neelammahara Road, Katuwawala, Boralesgamuwa, Sri Lanka.
Telephone : 0094 01 517037 / 517365 / 519727, Fax : 0094 01 509806, E-Mail : els@lanka.com.



**POINT LOAD TEST
ASTM D 5731-02**

Test Format No: ELS-ML-35

Revision No. 00

Project data:

Client: J. M. S. T. W. Jayasinghe

Project: MSc. Research Project

Sample data:

Sample Description: Rock (Granet Granulite)

Lab Ref.No. R/0001

Sample No.: 108

Job No: -

Depth: -

Date of Testing: 17.05.2019

Test data:

Date of Report: 18.05.2019

Speciman number.		01
Sample diameter	mm	54.60
Sectional Area of the Sample	mm ²	2341.40
Failure Load	kN	21.94
Point Load index	N/mm ²	7.360
Size correction factor		1.040
Size corrected point load strength index, $I_{sp(50)}$	N/mm ²	7.66
Average of Size corrected point load strength index, $I_{sp(50)}$	N/mm ²	-

Note: Only one Specimen was tested as per the request.

ENGINEERING & LABORATORY SERVICES (PVT) LTD

62/3, Neelammahara Road, Katuwawala, Boralesgamuwa, Sri Lanka.

Telephone : 0094 01 517037 / 517365 / 519727, Fax : 0094 01 509806, E-Mail : els@lanka.com.



**POINT LOAD TEST
ASTM D 5731-02**

Test Format No: ELS-ML-35

Revision No. 00

Project data:

Client: J. M. S. T. W. Jayasinghe

Project: MSc. Research Project

Sample data:

Sample Description: Rock (Granet Granulite)

Lab Ref.No. R/0001

Sample No.: 111

Job No: -

Depth: -

Date of Testing: 17.05.2019

Date of Report: 18.05.2019

Test data:

Speciman number.		01
Sample diameter	mm	54.00
Sectional Area of the Sample	mm ²	2290.23
Failure Load	kN	20.66
Point Load index	N/mm ²	7.085
Size correction factor		1.035
Size corrected point load strength index, $I_{sp(50)}$	N/mm ²	7.33
Average of Size corrected point load strength index, $I_{sp(50)}$	N/mm ²	-

Note: Only one Specimen was tested as per the request.

ENGINEERING & LABORATORY SERVICES (PVT) LTD

62/3, Neelammahara Road, Katuwawala, Boralesgamuwa, Sri Lanka.

Telephone : 0094 01 517037 / 517365 / 519727, Fax : 0094 01 509806, E-Mail : els@lanka.com.

Annex F: Sample SG Test reports for Garnet Granulite Rock specimens
tested



**SPECIFIC GRAVITY & WATER ABSORPTION OF
COARSE AGGREGATE
TEST METHOD - BS 812: PART 2**

Test Format No: ELS-ML-18

Revision No. 00

Project data:

Client: J. M. S. T. W. Jayasinghe

Project: MSc. Research Project

Sample data:

Sample Description: Rock (Granet Granulite)

Lab Ref. No. R/0001

Sample No.: 83

Date of testing: 16.05.2019

Location: -

Date of Report: 17.05.2019

Test Data:

Specimen No.:	1
Weight of oven Dried Sample in air (g)	395.7
Weight of SSD Sample in air (g)	396.9
Weight of SSD Sample in water (g)	256.5
Relative Density on SSD Basis	2.827
Relative Density on an Oven Dried Basis	2.818
Apparent Relative Density	2.843
Water Absorption (% of Dry Basis)	0.30

Apparent Relative Density = 2.84

Water Absorption (% of Dry Basis) = 0.30



Note:* This report refers specially to the sample analyzed.

ENGINEERING & LABORATORY SERVICES (PVT) LTD

62/3, Neelammahara Road, Katuwawala, Boralessgamuwa, Sri Lanka.

Telephone : 0094 011 4309494/ 2517037 / 2517365, Fax : 0094 01 2509806, E-Mail : els@elslanka.com.

Annex G: Sample UCS Test reports for Charnokitic Gneiss Rock
specimens tested

	UNCONFINED COMPRESSIVE STRENGTH TEST ON INTACT ROCK CORE SPECIMENS		Test Format No:	ELS-ML-36
	TEST METHOD -ASTM D 2938		Revision No.	00
Project data:				
Client:	J. M. S. T. W. Jayasinghe			
Project :	MSc. Research Project			
Sample data:				
Sample description:	Rock (Charnokitic Gneiss)	Lab ref. no.	R/0001	
Sample No.	01	Date of Testing:	15.05.2019	
Source:	-	Date of Report:	16.05.2019	
Test Data:				
Specimen No.:			01	
Sampling Depth(m)			-	
Specimen Diameter	cm		5.47	
Specimen Length	cm		10.56	
Sectional area of the Specimen	cm ²		23.47	
Volume of Specimen	cm ³		247.86	
Weight of specimen	g		705.0	
Unit Weight	g/cm ³		2.84	
Failure Load	kN		165.2	
Measured Compressive Strength	N/mm ²		70.40	
Correction Factor for height to diameter ratio			1.004	
Corrected Compressive Strength	N/mm ²		70.10	
Mode of Failure				

ENGINEERING & LABORATORY SERVICES (PVT) LTD

62/3, Neelammahara Road, Katuwawala, Boralessgamuwa, Sri Lanka.

Telephone : 0094 011 4309494/ 2517037 / 2517365, Fax : 0094 01 2509806, E-Mail : els@lanka.com.

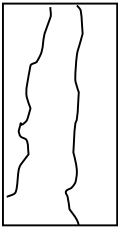
	UNCONFINED COMPRESSIVE STRENGTH TEST ON INTACT ROCK CORE SPECIMENS		Test Format No:	ELS-ML-36
	TEST METHOD -ASTM D 2938		Revision No.	00
Project data:				
Client:	J. M. S. T. W. Jayasinghe			
Project :	MSc. Research Project			
Sample data:				
Sample description:	Rock (Charnokitic Gneiss)	Lab ref. no.	R/0001	
Sample No.	02	Date of Testing:	15.05.2019	
Source:	-	Date of Report:	16.05.2019	
Test Data:				
Specimen No.:			01	
Sampling Depth(m)			-	
Specimen Diameter	cm		5.43	
Specimen Length	cm		10.73	
Sectional area of the Specimen	cm ²		23.19	
Volume of Specimen	cm ³		248.78	
Weight of specimen	g		703.0	
Unit Weight	g/cm ³		2.83	
Failure Load	kN		137.6	
Measured Compressive Strength	N/mm ²		59.34	
Correction Factor for height to diameter ratio			1.002	
Corrected Compressive Strength	N/mm ²		59.25	
Mode of Failure				

ENGINEERING & LABORATORY SERVICES (PVT) LTD

62/3, Neelammahara Road, Katuwawala, Boralessgamuwa, Sri Lanka.

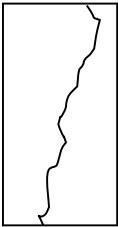

Telephone : 0094 011 4309494/ 2517037 / 2517365, Fax : 0094 01 2509806, E-Mail : els@lanka.com.

	UNCONFINED COMPRESSIVE STRENGTH TEST ON INTACT ROCK CORE SPECIMENS		Test Format No:	ELS-ML-36
	TEST METHOD -ASTM D 2938		Revision No.	00
Project data:				
Client:	J. M. S. T. W. Jayasinghe			
Project :	MSc. Research Project			
Sample data:				
Sample description:	Rock (Charnokitic Gneiss)	Lab ref. no.	R/0001	
Sample No.	03	Date of Testing:	15.05.2019	
Source:	-	Date of Report:	16.05.2019	
Test Data:				
Specimen No.:			01	
Sampling Depth(m)			-	
Specimen Diameter		cm	5.47	
Specimen Length		cm	10.57	
Sectional area of the Specimen		cm ²	23.50	
Volume of Specimen		cm ³	248.39	
Weight of specimen		g	709.0	
Unit Weight		g/cm ³	2.85	
Failure Load		kN	155.4	
Measured Compressive Strength		N/mm ²	66.13	
Correction Factor for height to diameter ratio			1.004	
Corrected Compressive Strength		N/mm ²	65.85	
Mode of Failure				

ENGINEERING & LABORATORY SERVICES (PVT) LTD

62/3, Neelammahara Road, Katuwawala, Boralessgamuwa, Sri Lanka.

Telephone : 0094 011 4309494/ 2517037 / 2517365, Fax : 0094 01 2509806, E-Mail : els@lanka.com.

	UNCONFINED COMPRESSIVE STRENGTH TEST ON INTACT ROCK CORE SPECIMENS TEST METHOD -ASTM D 2938		Test Format No:	ELS-ML-36
			Revision No.	00
Project data:				
Client:	J. M. S. T. W. Jayasinghe			
Project :	MSc. Research Project			
Sample data:				
Sample description:	Rock (Charnokitic Gneiss)	Lab ref. no.	R/0001	
Sample No.	04	Date of Testing:	15.05.2019	
Source:	-	Date of Report:	16.05.2019	
Test Data:				
Specimen No.:			01	
Sampling Depth(m)			-	
Specimen Diameter	cm		5.48	
Specimen Length	cm		10.74	
Sectional area of the Specimen	cm ²		23.59	
Volume of Specimen	cm ³		253.39	
Weight of specimen	g		713.0	
Unit Weight	g/cm ³		2.81	
Failure Load	kN		117.3	
Measured Compressive Strength	N/mm ²		49.74	
Correction Factor for height to diameter ratio			1.002	
Corrected Compressive Strength	N/mm ²		49.62	
Mode of Failure				

ENGINEERING & LABORATORY SERVICES (PVT) LTD

62/3, Neelammahara Road, Katuwawala, Boralessgamuwa, Sri Lanka.

Telephone : 0094 011 4309494/ 2517037 / 2517365, Fax : 0094 01 2509806, E-Mail : els@lanka.com.

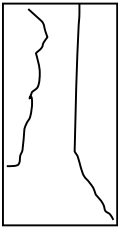
	UNCONFINED COMPRESSIVE STRENGTH TEST ON INTACT ROCK CORE SPECIMENS TEST METHOD -ASTM D 2938		Test Format No:	ELS-ML-36
			Revision No.	00
Project data:				
Client:	J. M. S. T. W. Jayasinghe			
Project :	MSc. Research Project			
Sample data:				
Sample description:	Rock (Charnokitic Gneiss)	Lab ref. no.	R/0001	
Sample No.	18	Date of Testing:	15.05.2019	
Source:	-	Date of Report:	16.05.2019	
Test Data:				
Specimen No.:			01	
Sampling Depth(m)			-	
Specimen Diameter	cm		5.46	
Specimen Length	cm		10.77	
Sectional area of the Specimen	cm ²		23.39	
Volume of Specimen	cm ³		251.94	
Weight of specimen	g		716.0	
Unit Weight	g/cm ³		2.84	
Failure Load	kN		135.1	
Measured Compressive Strength	N/mm ²		57.75	
Correction Factor for height to diameter ratio			1.002	
Corrected Compressive Strength	N/mm ²		57.66	
Mode of Failure				

ENGINEERING & LABORATORY SERVICES (PVT) LTD

62/3, Neelammahara Road, Katuwawala, Boralessgamuwa, Sri Lanka.

Telephone : 0094 011 4309494/ 2517037 / 2517365, Fax : 0094 01 2509806, E-Mail : els@lanka.com.

Annex H: Sample PLI Test reports for Charnokitic Gneiss Rock
specimens tested



**POINT LOAD TEST
ASTM D 5731-02**

Test Format No: ELS-ML-35
Revision No. 00

Project data:

Client: J. M. S. T. W. Jayasinghe
Project: MSc. Research Project

Sample data:

Sample Description: Rock (Chamokitic Gneiss) Lab Ref.No. R/0001
Sample No.: 01 Job No: -
Depth: - Date of Testing: 16.05.2019
Date of Report: 17.05.2019

Test data:

Speciman number.		01
Sample diameter	mm	53.90
Sectional Area of the Sample	mm ²	2281.75
Failure Load	kN	22.66
Point Load index	N/mm ²	7.800
Size correction factor		1.034
Size corrected point load strength index, $f_{sp(50)}$	N/mm ²	8.07
Average of Size corrected point load strength index, $f_{sp(50)}$	N/mm ²	-

Note: Only one Specimen was tested.

ENGINEERING & LABORATORY SERVICES (PVT) LTD

62/3, Neelammahara Road, Katuwawala, Boralesgamuwa, Sri Lanka.
Telephone : 0094 01 517037 / 517365 / 519727, Fax : 0094 01 509806, E-Mail : els@lanka.com.



**POINT LOAD TEST
ASTM D 5731-02**

Test Format No: ELS-ML-35

Revision No. 00

Project data:

Client: J. M. S. T. W. Jayasinghe

Project: MSc. Research Project

Sample data:

Sample Description: Rock (Chamokitic Gneiss)

Sample No.: 02

Depth: -

Lab Ref.No. R/0001

Job No: -

Date of Testing: 16.05.2019

Date of Report: 17.05.2019

Test data:

Speciman number.		01
Sample diameter	mm	54.00
Sectional Area of the Sample	mm ²	2290.23
Failure Load	kN	18.12
Point Load index	N/mm ²	6.214
Size correction factor		1.035
Size corrected point load strength index, $I_{sp(50)}$	N/mm ²	6.43
Average of Size corrected point load strength index, $I_{sp(50)}$	N/mm ²	-

Note: Only one Specimen was tested.

ENGINEERING & LABORATORY SERVICES (PVT) LTD

62/3, Neelammahara Road, Katuwawala, Boralesgamuwa, Sri Lanka.

Telephone : 0094 01 517037 / 517365 / 519727, Fax : 0094 01 509806, E-Mail : els@lanka.com.



**POINT LOAD TEST
ASTM D 5731-02**

Test Format No: ELS-ML-35

Revision No. 00

Project data:

Client: J. M. S. T. W. Jayasinghe

Project: MSc. Research Project

Sample data:

Sample Description: Rock (Chamokitic Gneiss)

Sample No.: 03

Depth: -

Lab Ref.No. R/0001

Job No: -

Date of Testing: 16.05.2019

Date of Report: 17.05.2019

Test data:

Speciman number.		01
Sample diameter	mm	54.30
Sectional Area of the Sample	mm ²	2315.74
Failure Load	kN	20.65
Point Load index	N/mm ²	7.004
Size correction factor		1.038
Size corrected point load strength index, $I_{sp(50)}$	N/mm ²	7.27
Average of Size corrected point load strength index, $I_{sp(50)}$	N/mm ²	-

Note: Only one Specimen was tested.

ENGINEERING & LABORATORY SERVICES (PVT) LTD

62/3, Neelammahara Road, Katuwawala, Boralesgamuwa, Sri Lanka.

Telephone : 0094 01 517037 / 517365 / 519727, Fax : 0094 01 509806, E-Mail : els@lanka.com.



**POINT LOAD TEST
ASTM D 5731-02**

Test Format No: ELS-ML-35

Revision No. 00

Project data:

Client: J. M. S. T. W. Jayasinghe

Project: MSc. Research Project

Sample data:

Sample Description: Rock (Chamokitic Gneiss)

Sample No.: 04

Depth: -

Lab Ref.No. R/0001

Job No: -

Date of Testing: 16.05.2019

Date of Report: 17.05.2019

Test data:

Speciman number.		01
Sample diameter	mm	54.30
Sectional Area of the Sample	mm ²	2315.74
Failure Load	kN	14.91
Point Load index	N/mm ²	5.057
Size correction factor		1.038
Size corrected point load strength index, $f_{s(50)}$	N/mm ²	5.25
Average of Size corrected point load strength index, $f_{s(50)}$	N/mm ²	-

Note: Only one Specimen was tested.

ENGINEERING & LABORATORY SERVICES (PVT) LTD

62/3, Neelammahara Road, Katuwawala, Boralesgamuwa, Sri Lanka.

Telephone : 0094 01 517037 / 517365 / 519727, Fax : 0094 01 509806, E-Mail : els@lanka.com.



**POINT LOAD TEST
ASTM D 5731-02**

Test Format No: ELS-ML-35
Revision No. 00

Project data:

Client: J. M. S. T. W. Jayasinghe
Project: MSc. Research Project

Sample data:

Sample Description: Rock (Chamokitic Gneiss) Lab Ref.No. R/0001
Sample No.: 18 Job No: -
Depth: - Date of Testing: 16.05.2019
Date of Report: 17.05.2019

Test data:

Speciman number.		01
Sample diameter	mm	54.40
Sectional Area of the Sample	mm ²	2324.28
Failure Load	kN	12.10
Point Load index	N/mm ²	4.089
Size correction factor		1.039
Size corrected point load strength index, $I_{sp(50)}$	N/mm ²	4.25
Average of Size corrected point load strength index, $I_{sp(50)}$	N/mm ²	-

Note: Only one Specimen was tested.

ENGINEERING & LABORATORY SERVICES (PVT) LTD

62/3, Neelammahara Road, Katuwawala, Boralesgamuwa, Sri Lanka.
Telephone : 0094 01 517037 / 517365 / 519727, Fax : 0094 01 509806, E-Mail : els@lanka.com.

Annex I: Sample SG Test reports for Charnokitic Gneiss Rock specimens
tested



**SPECIFIC GRAVITY & WATER ABSORPTION OF
COARSE AGGREGATE
TEST METHOD - BS 812: PART 2**

Test Format No: ELS-ML-18

Revision No. 00

Project data:

Client: J. M. S. T. W. Jayasinghe

Project: MSc. Research Project

Sample data:

Sample Description: Rock (Charnokitic Gneiss) **Lab Ref. No.** R/0001

Sample No.: 01 **Date of testing:** 16.05.2019

Location: - **Date of Report:** 17.05.2019

Test Data:

Specimen No.:	01
Weight of oven Dried Sample in air (g)	435.4
Weight of SSD Sample in air (g)	436.3
Weight of SSD Sample in water (g)	273.8
Relative Density on SSD Basis	2.685
Relative Density on an Oven Dried Basis	2.679
Apparent Relative Density	2.694
Water Absorption (% of Dry Basis)	0.21

Apparent Relative Density = 2.69
Water Absorption (% of Dry Basis) = 0.21



Note:* This report refers specially to the sample analyzed.

ENGINEERING & LABORATORY SERVICES (PVT) LTD

62/3, Neelammahara Road, Katuwawala, Boralesgamuwa, Sri Lanka.

Telephone : 0094 011 4309494/ 2517037 / 2517365, Fax : 0094 01 2509806, E-Mail : els@elslanka.com.



Annex J: Sample UCS Test reports for Biotite Gneiss Rock specimens
tested

	UNCONFINED COMPRESSIVE STRENGTH TEST ON INTACT ROCK CORE SPECIMENS TEST METHOD -ASTM D 2938		Test Format No:	ELS-ML-36
			Revision No.	00
Project data:				
Client:	J. M. S. T. W. Jayasinghe			
Project :	MSc. Research Project			
Sample data:				
Sample description:	Rock (Biotite Gneiss)	Lab ref. no.	R/0001	
Sample No.	05	Date of Testing:	15.05.2019	
Source:	-	Date of Report:	16.05.2019	
Test Data:				
Specimen No.:			01	
Sampling Depth(m)			-	
Specimen Diameter		cm	5.47	
Specimen Length		cm	10.56	
Sectional area of the Specimen		cm ²	23.47	
Volume of Specimen		cm ³	247.86	
Weight of specimen		g	685.0	
Unit Weight		g/cm ³	2.76	
Failure Load		kN	107.9	
Measured Compressive Strength		N/mm ²	45.97	
Correction Factor for height to diameter ratio			1.004	
Corrected Compressive Strength		N/mm ²	45.77	
Mode of Failure				

ENGINEERING & LABORATORY SERVICES (PVT) LTD

62/3, Neelammahara Road, Katuwawala, Boralesgamuwa, Sri Lanka.

Telephone : 0094 011 4309494/ 2517037 / 2517365, Fax : 0094 01 2509806, E-Mail : els@lanka.com.

	UNCONFINED COMPRESSIVE STRENGTH TEST ON INTACT ROCK CORE SPECIMENS TEST METHOD -ASTM D 2938		Test Format No:	ELS-ML-36
			Revision No.	00
Project data:				
Client:	J. M. S. T. W. Jayasinghe			
Project :	MSc. Research Project			
Sample data:				
Sample description:	Rock (Biotite Gneiss)	Lab ref. no.	R/0001	
Sample No.	06	Date of Testing:	15.05.2019	
Source:	-	Date of Report:	16.05.2019	
Test Data:				
Specimen No.:			01	
Sampling Depth(m)			-	
Specimen Diameter		cm	5.47	
Specimen Length		cm	10.56	
Sectional area of the Specimen		cm ²	23.47	
Volume of Specimen		cm ³	247.86	
Weight of specimen		g	695.0	
Unit Weight		g/cm ³	2.80	
Failure Load		kN	62.5	
Measured Compressive Strength		N/mm ²	26.64	
Correction Factor for height to diameter ratio			1.004	
Corrected Compressive Strength		N/mm ²	26.53	
Mode of Failure				

ENGINEERING & LABORATORY SERVICES (PVT) LTD

62/3, Neelammahara Road, Katuwawala, Boralessgamuwa, Sri Lanka.

Telephone : 0094 011 4309494/ 2517037 / 2517365, Fax : 0094 01 2509806, E-Mail : els@lanka.com.

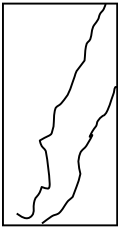
	UNCONFINED COMPRESSIVE STRENGTH TEST ON INTACT ROCK CORE SPECIMENS TEST METHOD -ASTM D 2938		Test Format No:	ELS-ML-36
			Revision No.	00
Project data:				
Client:	J. M. S. T. W. Jayasinghe			
Project :	MSc. Research Project			
Sample data:				
Sample description:	Rock (Biotite Gneiss)	Lab ref. no.	R/0001	
Sample No.	07	Date of Testing:	15.05.2019	
Source:	-	Date of Report:	16.05.2019	
Test Data:				
Specimen No.:			01	
Sampling Depth(m)			-	
Specimen Diameter	cm		5.48	
Specimen Length	cm		10.59	
Sectional area of the Specimen	cm ²		23.56	
Volume of Specimen	cm ³		249.55	
Weight of specimen	g		685.0	
Unit Weight	g/cm ³		2.74	
Failure Load	kN		100.0	
Measured Compressive Strength	N/mm ²		42.45	
Correction Factor for height to diameter ratio			1.004	
Corrected Compressive Strength	N/mm ²		42.28	
Mode of Failure				

ENGINEERING & LABORATORY SERVICES (PVT) LTD

62/3, Neelammahara Road, Katuwawala, Boralessgamuwa, Sri Lanka.

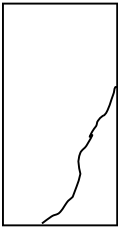

Telephone : 0094 011 4309494/ 2517037 / 2517365, Fax : 0094 01 2509806, E-Mail : els@lanka.com.

	UNCONFINED COMPRESSIVE STRENGTH TEST ON INTACT ROCK CORE SPECIMENS TEST METHOD -ASTM D 2938		Test Format No:	ELS-ML-36
			Revision No.	00
Project data:				
Client:	J. M. S. T. W. Jayasinghe			
Project :	MSc. Research Project			
Sample data:				
Sample description:	Rock (Biotite Gneiss)	Lab ref. no.	R/0001	
Sample No.	08	Date of Testing:	15.05.2019	
Source:	-	Date of Report:	16.05.2019	
Test Data:				
Specimen No.:			01	
Sampling Depth(m)			-	
Specimen Diameter	cm		5.48	
Specimen Length	cm		10.59	
Sectional area of the Specimen	cm ²		23.56	
Volume of Specimen	cm ³		249.55	
Weight of specimen	g		675.0	
Unit Weight	g/cm ³		2.70	
Failure Load	kN		83.5	
Measured Compressive Strength	N/mm ²		35.43	
Correction Factor for height to diameter ratio			1.004	
Corrected Compressive Strength	N/mm ²		35.29	
Mode of Failure				

ENGINEERING & LABORATORY SERVICES (PVT) LTD

62/3, Neelammahara Road, Katuwawala, Boralessgamuwa, Sri Lanka.

Telephone : 0094 011 4309494/ 2517037 / 2517365, Fax : 0094 01 2509806, E-Mail : els@lanka.com.

	UNCONFINED COMPRESSIVE STRENGTH TEST ON INTACT ROCK CORE SPECIMENS TEST METHOD -ASTM D 2938		Test Format No:	ELS-ML-36
			Revision No.	00
Project data:				
Client:	J. M. S. T. W. Jayasinghe			
Project :	MSc. Research Project			
Sample data:				
Sample description:	Rock (Biotite Gneiss)	Lab ref. no.	R/0001	
Sample No.	09	Date of Testing:	15.05.2019	
Source:	-	Date of Report:	16.05.2019	
Test Data:				
Specimen No.:			01	
Sampling Depth(m)			-	
Specimen Diameter	cm		5.48	
Specimen Length	cm		10.59	
Sectional area of the Specimen	cm ²		23.56	
Volume of Specimen	cm ³		249.55	
Weight of specimen	g		687.0	
Unit Weight	g/cm ³		2.75	
Failure Load	kN		123.4	
Measured Compressive Strength	N/mm ²		52.37	
Correction Factor for height to diameter ratio			1.004	
Corrected Compressive Strength	N/mm ²		52.16	
Mode of Failure				

ENGINEERING & LABORATORY SERVICES (PVT) LTD

62/3, Neelammahara Road, Katuwawala, Boralessgamuwa, Sri Lanka.

Telephone : 0094 011 4309494/ 2517037 / 2517365, Fax : 0094 01 2509806, E-Mail : els@lanka.com.

Annex K: Sample PLI Test reports for Biotite Gneiss Rock specimens
tested



**POINT LOAD TEST
ASTM D 5731-02**

Test Format No: ELS-ML-35
Revision No. 00

Project data:

Client: J. M. S. T. W. Jayasinghe
Project: MSc. Research Project

Sample data:

Sample Description: Rock (Biotite Gneiss) Lab Ref.No. R/0001
Sample No.: 05 Job No: -
Depth: - Date of Testing: 15.05.2019
Date of Report: 16.05.2019

Test data:

Speciman number.		01
Sample diameter	mm	54.70
Sectional Area of the Sample	mm ²	2349.99
Failure Load	kN	15.35
Point Load index	N/mm ²	5.130
Size correction factor		1.041
Size corrected point load strength index, $I_{sp(50)}$	N/mm ²	5.34
Average of Size corrected point load strength index, $I_{sp(50)}$	N/mm ²	-

Note: Only one Specimen was tested.

ENGINEERING & LABORATORY SERVICES (PVT) LTD

62/3, Neelammahara Road, Katuwawala, Boralesgamuwa, Sri Lanka.
Telephone : 0094 01 517037 / 517365 / 519727, Fax : 0094 01 509806, E-Mail : els@lanka.com.



**POINT LOAD TEST
ASTM D 5731-02**

Test Format No: ELS-ML-35

Revision No. 00

Project data:

Client: J. M. S. T. W. Jayasinghe

Project: MSc. Research Project

Sample data:

Sample Description: Rock (Biotite Gneiss)

Sample No.: 06

Depth: -

Lab Ref.No. R/0001

Job No: -

Date of Testing: 15.05.2019

Date of Report: 16.05.2019

Test data:

Speciman number.		01
Sample diameter	mm	54.70
Sectional Area of the Sample	mm ²	2349.99
Failure Load	kN	8.15
Point Load index	N/mm ²	2.724
Size correction factor		1.041
Size corrected point load strength index, $f_{s(50)}$	N/mm ²	2.84
Average of Size corrected point load strength index, $f_{s(50)}$	N/mm ²	-

Note: Only one Specimen was tested.

ENGINEERING & LABORATORY SERVICES (PVT) LTD

62/3, Neelammahara Road, Katuwawala, Boralesgamuwa, Sri Lanka.

Telephone : 0094 01 517037 / 517365 / 519727, Fax : 0094 01 509806, E-Mail : els@lanka.com.



**POINT LOAD TEST
ASTM D 5731-02**

Test Format No: ELS-ML-35
Revision No. 00

Project data:

Client: J. M. S. T. W. Jayasinghe
Project: MSc. Research Project

Sample data:

Sample Description: Rock (Biotite Gneiss) Lab Ref.No. R/0001
Sample No.: 07 Job No: -
Depth: - Date of Testing: 15.05.2019
Date of Report: 16.05.2019

Test data:

Speciman number.		01
Sample diameter	mm	54.80
Sectional Area of the Sample	mm ²	2358.59
Failure Load	kN	13.02
Point Load index	N/mm ²	4.336
Size correction factor		1.042
Size corrected point load strength index, $I_{sp(50)}$	N/mm ²	4.52
Average of Size corrected point load strength index, $I_{sp(50)}$	N/mm ²	-

Note: Only one Specimen was tested.

ENGINEERING & LABORATORY SERVICES (PVT) LTD

62/3, Neelammahara Road, Katuwawala, Boralesgamuwa, Sri Lanka.
Telephone : 0094 01 517037 / 517365 / 519727, Fax : 0094 01 509806, E-Mail : els@lanka.com.



**POINT LOAD TEST
ASTM D 5731-02**

Test Format No: ELS-ML-35
Revision No. 00

Project data:

Client: J. M. S. T. W. Jayasinghe
Project: MSc. Research Project

Sample data:

Sample Description: Rock (Biotite Gneiss) Lab Ref.No. R/0001
Sample No.: 08 Job No: -
Depth: - Date of Testing: 15.05.2019
Date of Report: 16.05.2019

Test data:

Speciman number.		01
Sample diameter	mm	54.80
Sectional Area of the Sample	mm ²	2358.59
Failure Load	kN	11.15
Point Load index	N/mm ²	3.713
Size correction factor		1.042
Size corrected point load strength index, $I_{sp(50)}$	N/mm ²	3.87
Average of Size corrected point load strength index, $I_{sp(50)}$	N/mm ²	-

Note: Only one Specimen was tested.

ENGINEERING & LABORATORY SERVICES (PVT) LTD

62/3, Neelammahara Road, Katuwawala, Boralesgamuwa, Sri Lanka.
Telephone : 0094 01 517037 / 517365 / 519727, Fax : 0094 01 509806, E-Mail : els@lanka.com.



**POINT LOAD TEST
ASTM D 5731-02**

Test Format No: ELS-ML-35
Revision No. 00

Project data:

Client: J. M. S. T. W. Jayasinghe
Project: MSc. Research Project

Sample data:

Sample Description: Rock (Biotite Gneiss) Lab Ref.No. R/0001
Sample No.: 09 Job No: -
Depth: - Date of Testing: 15.05.2019
Date of Report: 16.05.2019

Test data:

Speciman number.		01
Sample diameter	mm	54.80
Sectional Area of the Sample	mm ²	2358.59
Failure Load	kN	17.22
Point Load index	N/mm ²	5.734
Size correction factor		1.042
Size corrected point load strength index, $f_{sp(50)}$	N/mm ²	5.98
Average of Size corrected point load strength index, $f_{sp(50)}$	N/mm ²	-

Note: Only one Specimen was tested.

ENGINEERING & LABORATORY SERVICES (PVT) LTD

62/3, Neelammahara Road, Katuwawala, Boralesgamuwa, Sri Lanka.
Telephone : 0094 01 517037 / 517365 / 519727, Fax : 0094 01 509806, E-Mail : els@lanka.com.

Annex L: Sample SG Test reports for Biotite Gneiss Rock specimens
tested



**SPECIFIC GRAVITY & WATER ABSORPTION OF
COARSE AGGREGATE
TEST METHOD - BS 812: PART 2**

Test Format No: ELS-ML-18

Revision No. 00

Project data:

Client: J. M. S. T. W. Jayasinghe

Project: MSc. Research Project

Sample data:

Sample Description: Rock (Biotite Gneiss) **Lab Ref. No.** R/0001

Sample No.: 05 **Date of testing:** 15.05.2019

Location: - **Date of Report:** 16.05.2019

Test Data:

Specimen No.:	1
Weight of oven Dried Sample in air (g)	435.4
Weight of SSD Sample in air (g)	436.3
Weight of SSD Sample in water (g)	283.3
Relative Density on SSD Basis	2.852
Relative Density on an Oven Dried Basis	2.846
Apparent Relative Density	2.863
Water Absorption (% of Dry Basis)	0.21

Apparent Relative Density = 2.86

Water Absorption (% of Dry Basis) = 0.21

Note:* This report refers specially to the sample analyzed.

ENGINEERING & LABORATORY SERVICES (PVT) LTD

62/3, Neelammahara Road, Katuwawala, Boralessgamuwa, Sri Lanka.

Telephone : 0094 011 4309494/ 2517037 / 2517365, Fax : 0094 01 2509806, E-Mail : els@elslanka.com.

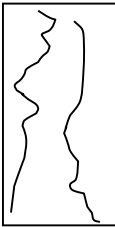

Annex M: Sample UCS Test reports for Garnet Biotite Gneiss Rock
specimens tested

	UNCONFINED COMPRESSIVE STRENGTH TEST ON INTACT ROCK CORE SPECIMENS TEST METHOD -ASTM D 2938		Test Format No:	ELS-ML-36
			Revision No.	00
Project data:				
Client:	J. M. S. T. W. Jayasinghe			
Project :	MSc. Research Project			
Sample data:				
Sample description:	Rock(Garnet Biotite Gneiss)	Lab ref. No:	R/0001	
Sample No.	32	Date of Testing:	15.06.2019	
Source:	-	Date of Report:	16.05.2019	
Test Data:				
Specimen No.:			01	
Sampling Depth(m)			-	
Specimen Diameter	cm		5.45	
Specimen Length	cm		10.73	
Sectional area of the Specimen	cm ²		23.30	
Volume of Specimen	cm ³		250.08	
Weight of specimen	g		705.0	
Unit Weight	g/cm ³		2.82	
Failure Load	kN		227.1	
Measured Compressive Strength	N/mm ²		97.48	
Correction Factor for height to diameter ratio			1.002	
Corrected Compressive Strength	N/mm ²		97.30	
Mode of Failure				

ENGINEERING & LABORATORY SERVICES (PVT) LTD

62/3, Neelammahara Road, Katuwawala, Boralesgamuwa, Sri Lanka.

Telephone : 0094 011 4309494/ 2517037 / 2517365, Fax : 0094 01 2509806, E-Mail : els@lanka.com.

	UNCONFINED COMPRESSIVE STRENGTH TEST ON INTACT ROCK CORE SPECIMENS TEST METHOD -ASTM D 2938		Test Format No:	ELS-ML-36
			Revision No.	00
Project data:				
Client:	J. M. S. T. W. Jayasinghe			
Project :	MSc. Research Project			
Sample data:				
Sample description:	Rock(Garnet Biotite Gneiss)	Lab ref. No:	R/0001	
Sample No.	33	Date of Testing:	15.06.2019	
Source:	-	Date of Report:	16.05.2019	
Test Data:				
Specimen No.:			01	
Sampling Depth(m)			-	
Specimen Diameter	cm		5.45	
Specimen Length	cm		10.79	
Sectional area of the Specimen	cm ²		23.33	
Volume of Specimen	cm ³		251.71	
Weight of specimen	g		718.0	
Unit Weight	g/cm ³		2.85	
Failure Load	kN		316.1	
Measured Compressive Strength	N/mm ²		135.48	
Correction Factor for height to diameter ratio			1.001	
Corrected Compressive Strength	N/mm ²		135.31	
Mode of Failure				

ENGINEERING & LABORATORY SERVICES (PVT) LTD

62/3, Neelammahara Road, Katuwawala, Boralesgamuwa, Sri Lanka.

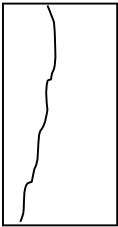

Telephone : 0094 011 4309494/ 2517037 / 2517365, Fax : 0094 01 2509806, E-Mail : els@lanka.com.

	UNCONFINED COMPRESSIVE STRENGTH TEST ON INTACT ROCK CORE SPECIMENS TEST METHOD -ASTM D 2938		Test Format No:	ELS-ML-36
			Revision No.	00
Project data:				
Client:	J. M. S. T. W. Jayasinghe			
Project :	MSc. Research Project			
Sample data:				
Sample description:	Rock(Garnet Biotite Gneiss)	Lab ref. No:	R/0001	
Sample No.	35	Date of Testing:	15.06.2019	
Source:	-	Date of Report:	16.05.2019	
Test Data:				
Specimen No.:			01	
Sampling Depth(m)			-	
Specimen Diameter	cm		5.44	
Specimen Length	cm		10.60	
Sectional area of the Specimen	cm ²		23.27	
Volume of Specimen	cm ³		246.75	
Weight of specimen	g		684.0	
Unit Weight	g/cm ³		2.77	
Failure Load	kN		196.7	
Measured Compressive Strength	N/mm ²		84.50	
Correction Factor for height to diameter ratio			1.003	
Corrected Compressive Strength	N/mm ²		84.23	
Mode of Failure				

ENGINEERING & LABORATORY SERVICES (PVT) LTD

62/3, Neelammahara Road, Katuwawala, Boralesgamuwa, Sri Lanka.

Telephone : 0094 011 4309494/ 2517037 / 2517365, Fax : 0094 01 2509806, E-Mail : els@lanka.com.

	UNCONFINED COMPRESSIVE STRENGTH TEST ON INTACT ROCK CORE SPECIMENS		Test Format No:	ELS-ML-36
	TEST METHOD -ASTM D 2938		Revision No.	00
Project data:				
Client:	J. M. S. T. W. Jayasinghe			
Project :	MSc. Research Project			
Sample data:				
Sample description:	Rock(Garnet Biotite Gneiss)	Lab ref. No:	R/0001	
Sample No.	47	Date of Testing:	15.06.2019	
Source:	-	Date of Report:	16.05.2019	
Test Data:				
Specimen No.:			01	
Sampling Depth(m)			-	
Specimen Diameter		cm	5.46	
Specimen Length		cm	10.74	
Sectional area of the Specimen		cm ²	23.44	
Volume of Specimen		cm ³	251.77	
Weight of specimen		g	671.0	
Unit Weight		g/cm ³	2.67	
Failure Load		kN	358.3	
Measured Compressive Strength		N/mm ²	152.85	
Correction Factor for height to diameter ratio			1.002	
Corrected Compressive Strength		N/mm ²	152.53	
Mode of Failure				

ENGINEERING & LABORATORY SERVICES (PVT) LTD

62/3, Neelammahara Road, Katuwawala, Boralesgamuwa, Sri Lanka.

Telephone : 0094 011 4309494/ 2517037 / 2517365, Fax : 0094 01 2509806, E-Mail : els@lanka.com.

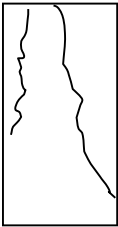
	UNCONFINED COMPRESSIVE STRENGTH TEST ON INTACT ROCK CORE SPECIMENS TEST METHOD -ASTM D 2938		Test Format No:	ELS-ML-36
			Revision No.	00
Project data:				
Client:	J. M. S. T. W. Jayasinghe			
Project :	MSc. Research Project			
Sample data:				
Sample description:	Rock(Garnet Biotite Gneiss)	Lab ref. No:	R/0001	
Sample No.	50	Date of Testing:	15.06.2019	
Source:	-	Date of Report:	16.05.2019	
Test Data:				
Specimen No.:			01	
Sampling Depth(m)			-	
Specimen Diameter	cm		5.46	
Specimen Length	cm		10.47	
Sectional area of the Specimen	cm ²		23.44	
Volume of Specimen	cm ³		245.52	
Weight of specimen	g		641.0	
Unit Weight	g/cm ³		2.61	
Failure Load	kN		255.8	
Measured Compressive Strength	N/mm ²		109.10	
Correction Factor for height to diameter ratio			1.005	
Corrected Compressive Strength	N/mm ²		108.53	
Mode of Failure				

ENGINEERING & LABORATORY SERVICES (PVT) LTD

62/3, Neelammahara Road, Katuwawala, Boralesgamuwa, Sri Lanka.

Telephone : 0094 011 4309494/ 2517037 / 2517365, Fax : 0094 01 2509806, E-Mail : els@lanka.com.

Annex N: Sample PLI Test reports for Garnet Biotite Gneiss Rock
specimens tested



**POINT LOAD TEST
ASTM D 5731-02**

Test Format No: ELS-ML-35
Revision No. 00

Project data:

Client: J. M. S. T. W. Jayasinghe
Project: MSc. Research Project

Sample data:

Sample Description: Rock(Garnet Biotite Gneiss) Lab Ref.No. R/0001
Sample No.: 32 Job No: -
Depth: - Date of Testing: 15.05.2019
Date of Report: 16.05.2019

Test data:

Speciman number.		01
Sample diameter	mm	54.50
Sectional Area of the Sample	mm ²	2332.83
Failure Load	kN	16.23
Point Load index	N/mm ²	5.464
Size correction factor		1.040
Size corrected point load strength index, $I_{sp(50)}$	N/mm ²	5.68
Average of Size corrected point load strength index, $I_{sp(50)}$	N/mm ²	-

Note: Only one Specimen was tested as per the request.

ENGINEERING & LABORATORY SERVICES (PVT) LTD

62/3, Neelammahara Road, Katuwawala, Boralesgamuwa, Sri Lanka.
Telephone : 0094 01 517037 / 517365 / 519727, Fax : 0094 01 509806, E-Mail : els@lanka.com.



**POINT LOAD TEST
ASTM D 5731-02**

Test Format No: ELS-ML-35

Revision No. 00

Project data:

Client: J. M. S. T. W. Jayasinghe

Project: MSc. Research Project

Sample data:

Sample Description: Rock(Garnet Biotite Gneiss)

Sample No.: 33

Depth: -

Lab Ref.No. R/0001

Job No: -

Date of Testing: 15.05.2019

Date of Report: 16.05.2019

Test data:

Speciman number.		01
Sample diameter	mm	54.50
Sectional Area of the Sample	mm ²	2332.83
Failure Load	kN	14.40
Point Load index	N/mm ²	4.848
Size correction factor		1.040
Size corrected point load strength index, $I_{sp(50)}$	N/mm ²	5.04
Average of Size corrected point load strength index, $I_{sp(50)}$	N/mm ²	-

Note: Only one Specimen was tested as per the request.

ENGINEERING & LABORATORY SERVICES (PVT) LTD

62/3, Neelammahara Road, Katuwawala, Boralesgamuwa, Sri Lanka.

Telephone : 0094 01 517037 / 517365 / 519727, Fax : 0094 01 509806, E-Mail : els@lanka.com.



**POINT LOAD TEST
ASTM D 5731-02**

Test Format No: ELS-ML-35

Revision No. 00

Project data:

Client: J. M. S. T. W. Jayasinghe

Project: MSc. Research Project

Sample data:

Sample Description: Rock(Garnet Biotite Gneiss)

Sample No.: 35

Depth: -

Lab Ref.No. R/0001

Job No: -

Date of Testing: 15.05.2019

Date of Report: 16.05.2019

Test data:

Speciman number.		01
Sample diameter	mm	54.50
Sectional Area of the Sample	mm ²	2332.83
Failure Load	kN	8.95
Point Load index	N/mm ²	3.013
Size correction factor		1.040
Size corrected point load strength index, $I_{sp(50)}$	N/mm ²	3.13
Average of Size corrected point load strength index, $I_{sp(50)}$	N/mm ²	-

Note: Only one Specimen was tested as per the request.

ENGINEERING & LABORATORY SERVICES (PVT) LTD

62/3, Neelammahara Road, Katuwawala, Boralesgamuwa, Sri Lanka.

Telephone : 0094 01 517037 / 517365 / 519727, Fax : 0094 01 509806, E-Mail : els@lanka.com.



**POINT LOAD TEST
ASTM D 5731-02**

Test Format No: ELS-ML-35

Revision No. 00

Project data:

Client: J. M. S. T. W. Jayasinghe

Project: MSc. Research Project

Sample data:

Sample Description: Rock(Garnet Biotite Gneiss)

Sample No.: 47

Depth: -

Lab Ref.No. R/0001

Job No: -

Date of Testing: 15.05.2019

Date of Report: 16.05.2019

Test data:

Speciman number.		01
Sample diameter	mm	54.50
Sectional Area of the Sample	mm ²	2332.83
Failure Load	kN	24.62
Point Load index	N/mm ²	8.289
Size correction factor		1.040
Size corrected point load strength index, $I_{sp(50)}$	N/mm ²	8.62
Average of Size corrected point load strength index, $I_{sp(50)}$	N/mm ²	-

Note: Only one Specimen was tested as per the request.

ENGINEERING & LABORATORY SERVICES (PVT) LTD

62/3, Neelammahara Road, Katuwawala, Boralesgamuwa, Sri Lanka.

Telephone : 0094 01 517037 / 517365 / 519727, Fax : 0094 01 509806, E-Mail : els@lanka.com.



**POINT LOAD TEST
ASTM D 5731-02**

Test Format No: ELS-ML-35

Revision No. 00

Project data:

Client: J. M. S. T. W. Jayasinghe

Project: MSc. Research Project

Sample data:

Sample Description: Rock(Garnet Biotite Gneiss)

Sample No.: 50

Depth: -

Lab Ref.No. R/0001

Job No: -

Date of Testing: 15.05.2019

Date of Report: 16.05.2019

Test data:

Speciman number.		01
Sample diameter	mm	54.50
Sectional Area of the Sample	mm ²	2332.83
Failure Load	kN	17.82
Point Load index	N/mm ²	5.999
Size correction factor		1.040
Size corrected point load strength index, $I_{sp(50)}$	N/mm ²	6.24
Average of Size corrected point load strength index, $I_{sp(50)}$	N/mm ²	-

Note: Only one Specimen was tested as per the request.

ENGINEERING & LABORATORY SERVICES (PVT) LTD

62/3, Neelammahara Road, Katuwawala, Boralesgamuwa, Sri Lanka.

Telephone : 0094 01 517037 / 517365 / 519727, Fax : 0094 01 509806, E-Mail : els@lanka.com.

Annex O: Sample SG Test reports for Garnet Biotite Gneiss Rock
specimens tested



**SPECIFIC GRAVITY & WATER ABSORPTION OF
COARSE AGGREGATE
TEST METHOD - BS 812: PART 2**

Test Format No: ELS-ML-18

Revision No. 00

Project data:

Client: J. M. S. T. W. Jayasinghe

Project: MSc. Research Project

Sample data:

Sample Description: Rock(Garnet Biotite Gneiss) **Lab Ref. No.** R/0001

Sample No.: 32 **Date of testing:** 15.05.2019

Location: - **Date of Report:** 16.05.2019

Test Data:

Specimen No.:	1
Weight of oven Dried Sample in air (g)	536.0
Weight of SSD Sample in air (g)	536.5
Weight of SSD Sample in water (g)	334.2
Relative Density on SSD Basis	2.652
Relative Density on an Oven Dried Basis	2.650
Apparent Relative Density	2.656
Water Absorption (% of Dry Basis)	0.09

Apparent Relative Density = 2.66
Water Absorption (% of Dry Basis) = 0.09

Note:* This report refers specially to the sample analyzed.

ENGINEERING & LABORATORY SERVICES (PVT) LTD

62/3, Neelammahara Road, Katuwawala, Boralesgamuwa, Sri Lanka.

Telephone : 0094 011 4309494/ 2517037 / 2517365, Fax : 0094 01 2509806, E-Mail : els@elslanka.com.