



# **A CONCEPTUAL DESIGN FOR A TOWER TYPE CONCENTRATING SOLAR POWER PLANT NEAR HAMBANTOTA**

A dissertation submitted to the  
Department of Electrical Engineering, University of Moratuwa  
in partial fulfillment of the requirements for the  
Degree of Master of Science

By

**NABR WIJAYAWARDHANA**

Supervised by:

Eng. WDAS Wijayapala

Eng. DG Rienzie Fernando.

Department of Electrical Engineering  
University of Moratuwa  
Sri Lanka

2010

94552



## Abstract

In this study the basics of a central receiver type solar thermal power plant including a thermal storage are studied. Further, the technical feasibility of a central receiver type solar thermal power plant near Hambantota is investigated. The requirement of a power plant and the size of the plant are determined. The availability of solar resources in the area and the best area to locate a solar thermal power plant is also studied. The other required resources such as water, lands, proximity to transmission lines are taken into consideration.

Further the impact on the environment and the possible measures to mitigate such impacts are examined.

In addition, the technical features of a central receiver type power plant are studied and a conceptual design for such a power plant has been developed. In the conceptual design, the total required number of heliostats or reflectors, the heliostat field layout, the receiver size, the thermal storage size and the tower height have been determined.

Finally, the economic feasibility of the plant is checked considering the available soft loan facilities which can be obtained from international development banks such as Global Environmental Facility (GEF), World Bank and Japan International Cooperation Agency (JICA). The economic benefits from the Carbon credit program have also been taken into account. Finally, it is concluded that certain cost reductions and economic conditions are required for the project to be viable.

## DECLARATION

The work submitted in this dissertation is the result of my own investigation, except where otherwise stated.

It has not already been accepted for any degree, and is also not being concurrently submitted for any other degree.

### ***UOM Verified Signature***

NABR Wijayawardhana

Date: 28<sup>th</sup> January 2010



University of Moratuwa, Sri Lanka.  
Electronic Theses & Dissertations  
[www.lib.mrt.ac.lk](http://www.lib.mrt.ac.lk)

We endorse the declaration by the candidate.

### ***UOM Verified Signature***

Eng. WDAS Wijayapala

Senior Lecturer

University of Moratuwa

### ***UOM Verified Signature***

Eng. DG Rienzie Fernando

Managing Director

Amithi Power Consultants (Pvt) Ltd

**D. G. RIENZIE FERNANDO**

B.Sc. Eng. (Hons)-C. Eng. MIE (SL)

11, 12, 13, 14, 15, 16, 17

Amithi Power Consultants (Pvt) Ltd

## ACKNOWLEDGEMENTS

This work has been carried out at the Department of Electrical Engineering, University of Moratuwa.

Foremost, I would like to express my sincere gratitude to my advisor Eng. WDAS Wijayapala, Senior Lecturer, University of Moratuwa for the continuous support of my M.Sc. study and research, for his patience, comments and immense knowledge. His guidance helped me in all the time of research and writing of this dissertation. I could not have imagined having a better advisor and a mentor for my M.Sc. study.

I take this opportunity to extend my earnest thanks to Eng. DG Rienzie Fernando, Managing Director, Amithi Power Consultants (Pvt) Ltd, who enlightened me the first glance of research and motivated me, whenever I discussed technical issues encouraging me to carry out this project successfully.

My sincere thanks also go to Eng. S Bogahawatte, Project Director, Lighting Sri Lanka Hambantota Project, Ceylon Electricity Board for his encouragement and leading me working on diverse exciting project works.

I thank my fellow colleague Roshan for the sleepless nights we were working together before deadlines, and for all the fun we had in the last two years. Also I thank my friends Prasanna, Dinesh and Sarath.

And I like to remind my brothers, Chathura and Sachintha. In particular, I am grateful to my fiancée Sashi for her love and continuous encouragement.

Last but not the least, I would like to thank my family: my parents Wijayawardhana and Ariyawathie, for bringing me up and supporting me spiritually throughout my life.

# CONTENTS

Declaration.....	i
Abstract.....	ii
Acknowledgement.....	iii
Contents.....	iv
List of Figures.....	vi
List of Tables.....	vii
List of Abbreviations.....	viii
<b>1 Introduction.....</b>	<b>1</b>
1.1 Background.....	1
1.2 Objective.....	2
1.3 Scope of work.....	2
<b>2 Problem Statement.....</b>	<b>3</b>
<b>3 Technology.....</b>	<b>5</b>
3.1 Solar Thermal Power.....	5
3.1.1 Power Towers.....	6
3.1.2 Parabolic Troughs.....	7
3.1.3 Dish /Engine Systems.....	8
<b>4 Site Selection.....</b>	<b>09</b>
4.1 Availability of Solar Resources.....	09
4.2 Availability of suitable Lands (Topography).....	11
4.3 Availability of Water.....	12
4.4 Proximity to Available Transmission.....	12
4.5 Impact on Environment.....	13
4.6 Other Considerations.....	13
<b>5 Conceptual Design of the Plant.....</b>	<b>14</b>
5.1 Determination of the Size of the Plant.....	14
5.2 The Methodology of Conceptual Design.....	15
5.3 Design Calculations.....	15
5.3.1. Design of Heliostats Field.....	17

5.3.2. Design of the Heliostat Field Layout .....	18
5.3.2.1. Cosine Effect .....	18
5.3.2.2. Shadowing & Blocking .....	21
5.3.2.3. Reflectance .....	22
5.3.2.4. Atmospheric transmittance .....	22
5.3.2.5. Field Layout .....	23
5.3.2.6. Tower Height .....	27
5.3.2.7. Atmospheric Transmittance in Tanamalwila Site ....	28
5.3.3 Design of the Receiver .....	29
5.3.4 Design of the Storage .....	30
5.3.5 Thermal Performance .....	31
<b>6 Environmental Impacts .....</b>	<b>33</b>
6.1 Impact on Environment in General .....	33
6.2 Minimization of Land Use Impacts .....	34
6.3 Displacement of CO <sub>2</sub> , NO <sub>x</sub> and SO <sub>2</sub> Emissions.....	35
<b>7 Economic Evaluation .....</b>	<b>36</b>
7.1 Cost Estimation .....	36
7.2 Estimation of Annual Energy Output .....	38
7.3 Evaluation of Economic Feasibility .....	39
7.4 Sensitivity Analysis .....	42
<b>8 Conclusion .....</b>	<b>45</b>
<b>References .....</b>	<b>46</b>
<b>Appendix A .....</b>	<b>48</b>
<b>Appendix B .....</b>	<b>51</b>
<b>Appendix C .....</b>	<b>52</b>
<b>Appendix D .....</b>	<b>55</b>

 University of Moratuwa, Sri Lanka.  
 Electronic Theses & Dissertations  
[www.lib.mrt.ac.lk](http://www.lib.mrt.ac.lk)



## ***List of Tables***

<b>Table</b>	<b>Page</b>
<b>Chapter 5</b>	
Table 5.1      Heliostats layout design results for tower height of 180m....	25
Table 5.2      Distance to furthest line of heliostats .....	27
Table 5.3 <i>The ratio between Peak DNI of a day to Average DNI of a day</i>	27
<b>Chapter 7</b>	
Table 7.1      Midterm Cost Estimations of Tanamalwila 50 MW Power Tower	36
Table 7.2      Long term Cost Estimations of Tanamalwila 50 MW Power Tower	37
Table 7.3      Input Parameters for Economic Evaluation.....	39
Table 7.4      Final Results of Economic Evaluation .....	41
Table 7.5      After Tax Net Equity Cash Flow.....	42
Table 7.6      LCOE vs. Capacity Factor.....	42
Table 7.7      LCOE vs. Real Discount Rate.....	43
Table 7.8      LCOE vs. Minimum Required IRR.....	43
Table 7.9      LCOE vs. Availability of Carbon Credit.....	43
Table 7.10      LCOE vs. Loan Term .....	44
Table 7.11      LCOE vs. Availability of BOI state .....	44
Table 7.12      LCOE vs. PPA escalation rate.....	44



## List of Abbreviations

<b>Term</b>	<b>Definition or Clarification</b>
ADB	Asian Development Bank
BOI	Board of Investment
CPV	Concentrating Photovoltaic
CSP	Concentrating Solar Power
CST	Concentrating Solar Thermal
DNI	Direct Normal Irradiance
GEF	Global Environmental Fund
HTF	Heat Transfer Fluid
IPP	Independent Power Producer
IRR	Internal Rate of Return
JICA	Japan International Cooperation Agency
kJ	Kilo Joules
kWe	Kilo Watts (electrical energy)
kWh	Kilo Watt Hours
kWt	Kilo Watts (thermal energy)
LCOE	Levelized Cost of Energy
LFR	Linear Fresnel Reflector
m	meters
MJ	Mega Joules
MVA	Mega Volt Amperes
MWh	Mega Watt Hours
NREL	National Renewable Energy Laboratory
PPA	Power Purchase Agreement
PV	Photovoltaic
USD	United States Dollars
°C	Celsius

# Chapter 01

---

## INTRODUCTION

### 1.1. Background

There are many alternative energy sources other than fossil fuels. The decision of what type of energy source should be utilized in each case must be made on the basis of economic, environmental, and safety considerations. Because of the desirable environmental and safety aspects, it is widely believed that the solar energy should be utilized instead of other alternative energy forms. Solar energy can be utilized sustainably without harming the environment.

It is now generally believed in the world that renewable energy technologies can meet much of the growing demand at prices that are equal or lower than those usually forecast for conventional energy. By the middle of the 21<sup>st</sup> century, renewable sources of energy could account for three fifths of the world's electricity market and two fifths of the market for fuels used directly [1]. Moreover, making a transition to a renewable energy-intensive economy would provide environmental and other benefits not measured in standard economic terms. It is envisaged that by 2050 the global carbon dioxide (CO<sub>2</sub>) emissions would be reduced to 75% of their 1985 levels, provided the energy efficiency and renewables are widely adopted [1]. In addition, such benefits could be achieved at no additional cost, because renewable energy is expected to be competitive with conventional energy.

In Sri Lanka too, a broad prolonged discussion has existed for at least three decades regarding renewables. Mini/micro hydros, solar PV systems and wind turbines have been in Sri Lanka for a certain period of time. However the possibility of large scale solar thermal power plants has not been considered. There are reasons for that. The first is that the most of these technologies are not mature enough and not widely available. The second is that the associated capital cost and the per unit energy cost are also higher.

However, the current situation in the world compels us to include these technologies into our future energy mix because of following reasons. The first is the uncertainty of oil prices. This was experienced in 2008 and the country suffered from the volatility. The cost of oil increased to unprecedented levels in no time, giving no space to breathe to developing economies like Sri Lanka. The second is as described above; the cost of solar thermal technologies will continue to decrease and will be competitive with other conventional technologies in the near future, say by 2020. The third is the energy security. It is said that the world is regionalizing into regions such as Europe, China, United States etc. There may be geo-political cold wars among these countries or regions. If we can secure our energy supply with available resources as much as possible, our economy will not be susceptible to external factors to the extent we experienced in the past. Further it will be able to harvest the benefits of carbon credit program while supporting the struggle against global warming.

## **1.2. The Objective**

To study and develop a conceptual design for a central receiver type concentrating solar power plant near Hambantota, and examine the economic viability of the project.



University of Moratuwa, Sri Lanka  
Electronic Theses & Dissertations  
www.lib.mrt.ac.lk

## **1.3. Scope of work**

The scope of the work of this study is given below,

- In this study, the best available site having rich solar resources near Hambantota area to build a central receiver type concentrating solar power plant (power tower) will be assessed.
- The study will justify, giving reasons, the suitability of a power tower near Hambantota area.
- The impact of plant on the environment and possible mitigation techniques will be discussed.
- The capacity of the plant and its components will be estimated. The study will include heliostats field design, receiver design and thermal storage calculations.
- Economic analysis with a sensitivity analysis will be incorporated to the study and the economic feasibility of the plant will also be discussed.

## PROBLEM STATEMENT

The possibility of large scale solar thermal power plants in Sri Lanka has never been studied. There are two reasons behind this; the high cost of unit of energy produced and novelty of large scale solar thermal power technology compared to conventional technologies. However now, large scale solar thermal power plants are being commercially operated in 2009. Two central receiver type solar thermal power plants, 11MW and 20MW are being operated in Spain. Therefore solar thermal power plants will be widely available in the world in a few years. It is forecast that large scale solar thermal power not only will become economical but will also be competitive with conventional power. Therefore even if it is not technically or economically viable to construct large scale solar thermal power plants in Sri Lanka today, the possibility of solar thermal power in the future requires to be studied.



University of Moratuwa, Sri Lanka.  
Electronic Theses & Dissertations

Further solar thermal power is a 100% green technology. Such technology can claim 0.015 to 0.03 USD for a kWh through the Carbon credit program which will reduce the cost of a kWh produced.

In this study the basics of a central receiver type solar thermal power plant including thermal storage will be studied. Further, the technical feasibility of a central receiver type solar thermal power plant near Hambantota will be studied. The requirement of a power plant and the size of the plant will be determined. The availability of solar resources in the area and the best area to locate a solar thermal power plant will be studied. The required other resources like water resources, lands, proximity to transmission lines shall also be studied.

Further the impact on the environment and the possible measures to mitigate such impacts will be examined.

The technical features of a central receiver type power plant will be further studied and a conceptual design of such power plant will be developed. In the conceptual

design the total required number heliostats or reflectors, the heliostat field layout, the receiver size, the thermal storage size and the tower height will be calculated.

Finally the economic feasibility of the plant will be determined considering the available soft loan facilities which can be obtained from an international development banks such as GEF and World Bank. The economic benefits of Carbon credit program will also be taken into account.



University of Moratuwa, Sri Lanka.  
Electronic Theses & Dissertations  
[www.lib.mrt.ac.lk](http://www.lib.mrt.ac.lk)

### 3.1. Solar Thermal Power

The concentrating solar power (CSP) technologies can be divided into two general categories. The first is Concentrating Solar Thermal (CST), which includes those concentrating the sun's energy on a thermal conductor and then using that heat to move an engine or a turbine. These usually take the form of a large power plant and can concentrate using mirrors in a line or around a point. The mirror array can be concave or flat - concentrating from 80 suns for the linear arrays (including trough systems and Linear Fresnel Reflector systems (LFR)) to over 1500 suns on the point arrays (including tower and dish-engine systems), with corresponding temperatures and variations of technology components to convert the heat into useful electricity. Because they generate heat, CST systems have relatively more costs in the operation and maintenance versus PV systems, but create the advantage of potentially storing the heat or using it in a hybrid configuration to make the power dispatchable; a significant advantage in integrating the power into main electrical grid. Because trough and power tower systems collect heat to drive central turbine-generators, they are best suited for large-scale plants: 50 MW or larger. Trough and tower plants, with their large central turbine generators and balance of plant equipment, can take advantage of economies of scale for cost reduction, as cost per kW goes down with increased size [2].

Alternatively, Concentrating Photovoltaic (CPV) technologies concentrate the sun's energy directly onto high efficiency PV materials to directly create electricity. These technologies use both mirrors and lenses and can be deployed in configurations that range from large systems to medium systems [2].

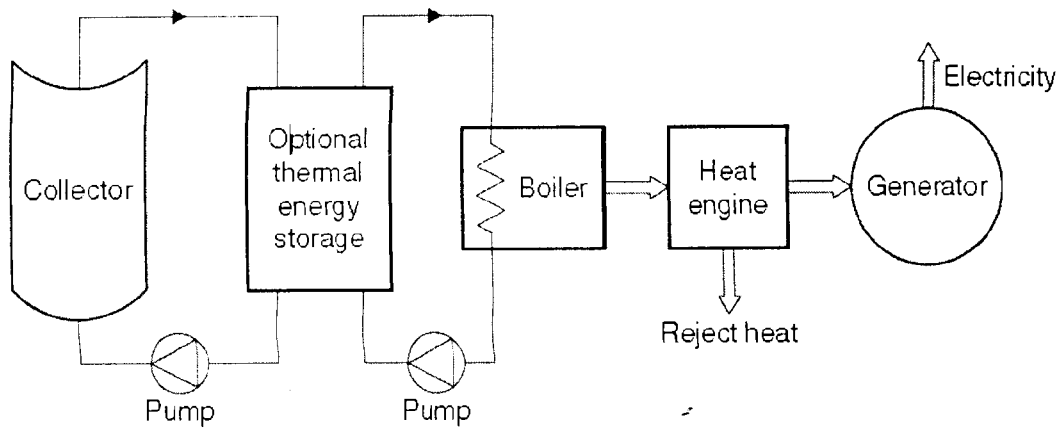

Figure 3.1: A schematic diagram of solar thermal power plant

### 3.1.1. Power Towers (Central Receiver Systems)

Power towers or central receiver systems use thousands of individual sun-tracking mirrors, called heliostats, to reflect solar energy onto a receiver located atop a tall tower. The receiver collects the sun's heat in a heat transfer fluid (eg. molten salt) that flows through the receiver. This is then passed optionally to storage and finally to a power conversion system, which converts the thermal energy into electricity and supplies it to the grid. Therefore, a central receiver system is composed of five main components: heliostats, including their tracking system; receiver; heat transport and exchange; thermal storage; and controls [3]. In many solar power studies, it has been observed that the collector represents the largest cost in the system; therefore, an efficient engine is justified to obtain maximum useful conversion of the collected energy. The power tower plants are quite large, generally 10 MWe or more, while the optimum sizes lie between 50–400 MW. It is estimated that power towers could generate electricity at around US\$ 0.055/kWh by 2020 [4].

The salt's heat energy is used to make steam to generate electricity in a conventional steam generator, located at the bottom of the tower. The storage system retains heat efficiently, so it can be stored for hours or even days before being used to generate electricity. The storage medium can be steam, molten salt, liquid sodium etc.

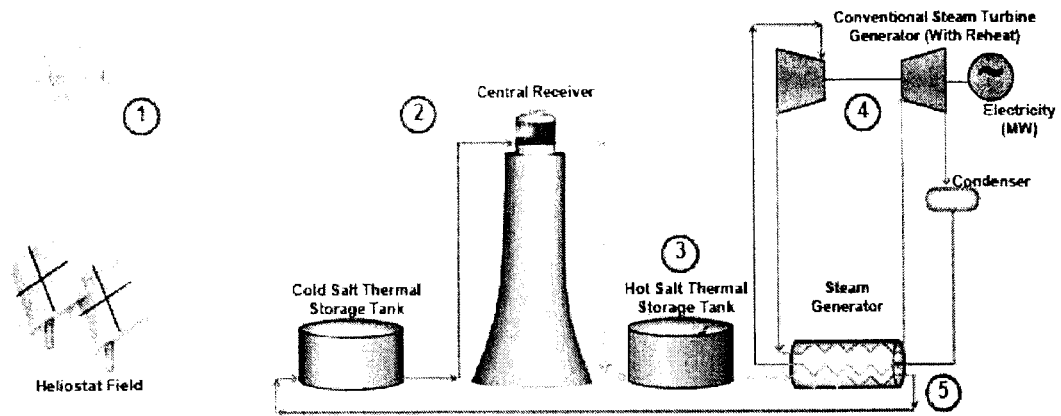

Figure 3.2: A simple diagram of a power tower

The heliostats reflect solar radiation to the receiver at the desired flux density at minimal cost. A variety of receiver shapes have been considered, including cylindrical receivers and cavity receivers. The optimum shape of the receiver is a function of radiation intercepted and absorbed thermal losses, cost, and design of the heliostat field. For a large heliostat field, a cylindrical receiver is best suited to be used with Rankine cycle engines. Another possibility is to use Brayton cycle turbines, which require higher temperatures (of about 1000°C) for their operation; in this case, cavity receivers with larger tower height to heliostat field area ratios are more suitable [5].

### 3.1.2. Parabolic Troughs

A parabolic trough solar collector is designed to concentrate the sun's rays via parabolic curved solar reflectors onto a heat absorber element – a “receiver” – located in the optical focal line of the collector. The solar collectors track the sun continuously. The key components of a parabolic trough power plant are mirrors, receivers and turbine technology. The receiver consists of a specially coated absorber tube which is embedded in an evacuated glass envelope. The absorbed solar radiation warms up the heat transfer fluid flowing through the absorber tube to almost 400°C. This is conducted along a heat exchanger in which steam is produced, which then generates power in the turbines. The output of the power plant is between 25 MW and 200 MW of electricity, at its peak. Due to the presence of the storage systems, the plant can keep working at a constant load [5].



### 3.1.3. Dish/Engine Systems

In solar dish/engine systems, parabolic dishes capture the solar radiation and transfer it to a Stirling engine – an engine which uses external heat sources to expand and contract a fluid – placed in the focus of the parabolic dish. This approach is particularly suited for decentralized electricity generation [5].



University of Moratuwa, Sri Lanka.  
Electronic Theses & Dissertations  
[www.lib.mrt.ac.lk](http://www.lib.mrt.ac.lk)

## SITE SELECTION

### 4.1. Availability of Solar Resources

Sri Lanka lies within the equatorial belt, a region where substantial solar resources exist throughout much of the year. Accordingly energy equivalent to 4.5~6.0 kWh/m<sup>2</sup>/day is available across the country which invites many solar applications [6]. However for CSP type plants, continuous availability of Direct Normal Irradiance of 5kWh/m<sup>2</sup>/day is required for its successful operation with currently available technologies [4]. Direct Normal Irradiance (DNI) is measured using equipment called pyrhelimeter. However measurement of DNI has not been done in weather stations in Sri Lanka [6].

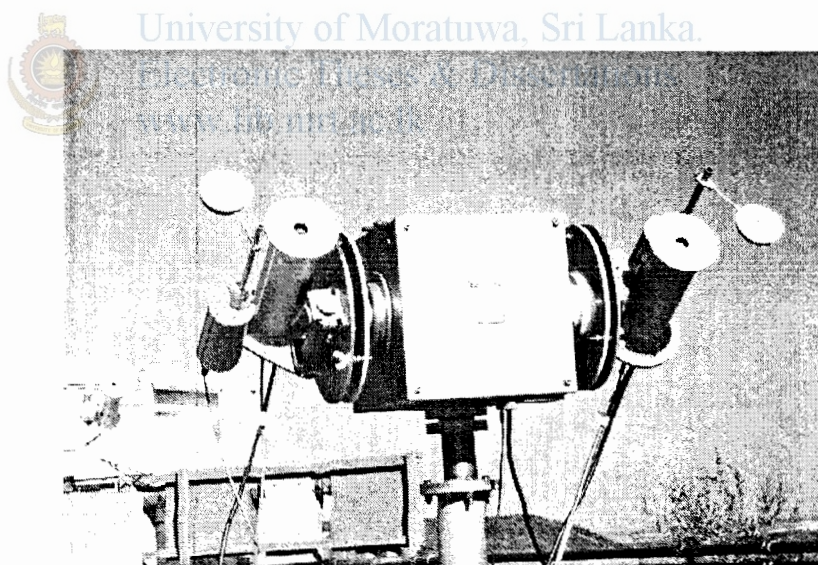

Figure 4.1: A pyrhelimeter in a site

An assessment of solar resources in Sri Lanka and Maldives was done by D. Renné, R. George, B. Marion and D. Heimiller from National Renewable Energy Laboratory of United States Department of Energy and C. Gueymard from Solar Consulting Services in 2003. The DNI was estimated using a model utilizing available solar resources and cloud cover databases obtained from nine weather stations.

Accordingly, the maximum DNI is available just 35km above Hambantota area having Average Annual DNI 4.5~5 kWh/m<sup>2</sup>/day. The size of the area having maximum DNI is more than 1500 km<sup>2</sup>. However the solar resource data given in the report has 40 km resolution only.

These data can be viewed using the Geospatial Toolkit (GsT) developed by NREL, which is a map-based software application that can be used for decision making and policy analysis in addition to planning for future wind energy projects. The GsT application utilizes Geographical Information Systems (GIS) to develop common scenarios to evaluate potential locations for solar or wind energy plants.

Much sophisticated sources to obtain weather data are SWERA Renewable Energy Resource Explorer (REREX) which is a web based tool and EnergyPlus program database where data can be downloaded in '\*.epw' format which can be viewed with DView software [7]. However digital weather data is not available for the selected area. The nearest place to selected area having digital weather data is Hambantota. Monthly DNI average values of Hambantota viewed by DView, is shown in figure 4.2.

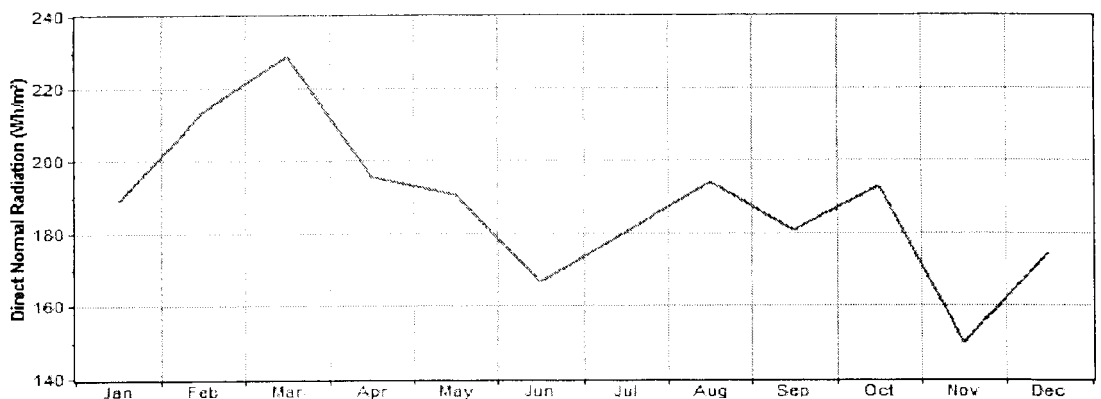

Figure 4.2: Monthly average DNI at Hambantota

Hence the area, 35 km above Hambantota which is the best for a CSP power plant according to the above report, was selected. The map indicating this area is shown in figure 4.3.

## 4.2. Availability of Suitable Lands (Topography)

The lands which have highest DNI consist of both suitable and unsuitable areas for a CSP power plant. The slope of the terrain should not be more than  $5^\circ$  for a Tower type CSP power plant [3]. The land should be relatively free from variations of elevation and should be flat as much as possible. And the lands should not be commercially valuable or agriculturally important lands. If the lands are owned by people, the cost of acquisition will be high.

A typical CSP plant requires about 2 to 40 ha of land per MW of installed capacity, depending on the plant's usage of heat storage facility. The size of the collector field for such plant, particularly one designed to provide heat-storage, is enormous. For example, a zero storage CSP plant requires 2 to 2.5 ha of land per MW of installed capacity, which increases to 3.25 ha per MW for a 6 hour storage plant. For modular type CSP tower type plant without storage the land requirement will be 1.6 ha per MW [3].

So if the plant size is 50 MW, the land requirement will be 121 ha without a thermal storage. For 16 hour storage this can be increased to 340 ha [4].

The terrain of the selected area was studied using Google Earth™ software. High resolution satellite images of the area were available. Accordingly a site near Tanamalwila area was selected for further studies considering several factors described below.

The slope of the terrain was studied using web based software tool called “Heywhats That Path Profiler™”, software supported by Google Maps™ which gives the ground profile from one point to another. The terrain of the selected site have the required slope, however leveling of the land may have to be done as the land's surface is not uniform.

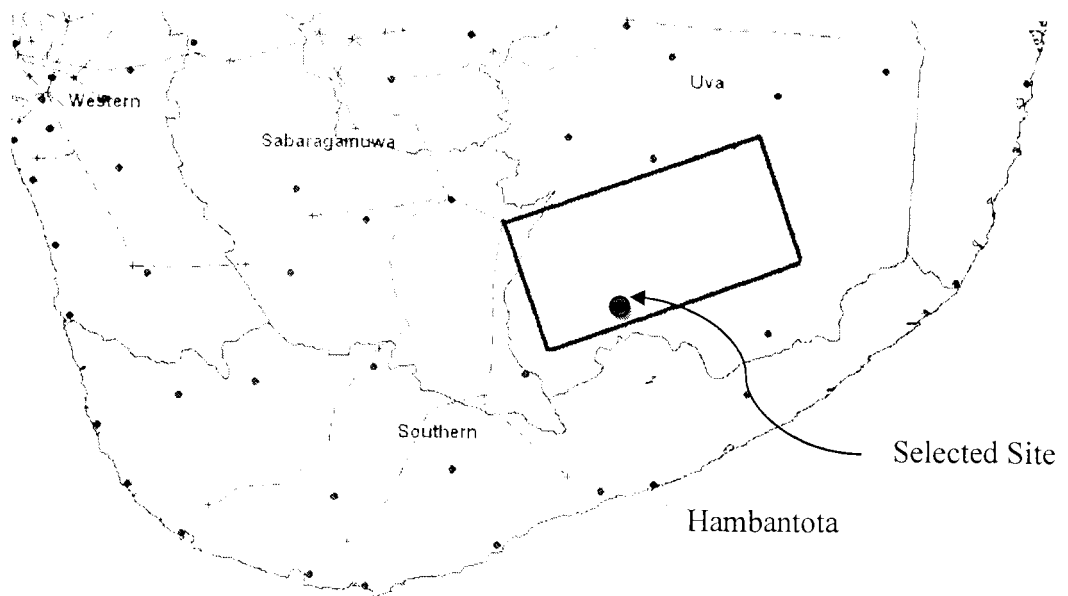

Figure 4.3: The area having annual DNI 4.5~5 kWh/m<sup>2</sup>/day and the selected site

The land use was studied using Geospatial Toolkit. The land value of the area is much less compared with other areas in the island.



University of Moratuwa, Sri Lanka.  
Electronic Theses & Dissertations  
www.lib.mrt.ac.lk

#### 4.3. Availability of Water

Availability of water is also a critical factor as CSP plants need continuous supply of water for steam generation, cooling and cleaning of solar mirrors. According to a research by Christopher Avery done in 2007, a CSP generating facility can be expected to consume approximately 9,000 m<sup>3</sup> of water, per year per MW [8]. The selected site is 5km near to a small river called “Kuda Oya”. The initial branch of “Malala Oya” is also at same distance. However the amount of water which can be obtained from “Kuda Oya” or “Malala Oya” throughout the year shall be studied further and it is not in the scope of this study.

#### 4.4. Proximity to Available Transmission

As the transmitting electricity generated by the CSP plant to the Grid involves investment, the length of the transmission line from CSP plant to Grid is also a critical factor. Further with the increase of the transmission line length, the power losses will

also be increased. The distance from selected site to Hambantota and Embilipitiya Grid Substations are approximately 33 km and 30km respectively.

#### **4.5. Impact on the Environment**

Operationally, the functioning of CSP plants is similar to the working of traditional steam turbines used to make steam for power generation other than the huge land requirement.

As the above selected lands for the plant are mostly agricultural lands [9], the loss of lands for agriculture can be a problem. However, as the heliostats have a considerable height, a cultivation which has low height can be done in the heliostats field. But, access shall be kept for cleaning vehicle of mirrors. This matter will be described in details in chapter 6 of this report.

The regional flora and fauna will not be affected as harmful substances are not discharged. However an electric fence will be needed to obstruct any intrusion of wild elephants.



University of Moratuwa, Sri Lanka.  
Electronic Theses & Dissertations  
[www.lib.mrt.ac.lk](http://www.lib.mrt.ac.lk)

Since most of the lands are not agricultural or forests, clearing of land will not have a considerable impact on the environment. However problems associated with acquiring lands and resettlement can be arisen.

#### **4.6. Other Considerations**

Proposals have been made to construct an airport of Udamattala, Hambantota which is situated below the selected area. However airplanes will not be affected by the reflectors, because the reflectors are designed to reflect sun rays exactly to the tower top. Hence a disturbance will not occur to airplanes or pilots by the reflected sun rays.

## CONCEPTUAL DESIGN OF THE PLANT

### 5.1. Determination of the Size of the Plant

The Hambantota area is being subjected to unprecedented development with the arrival of a new seaport. It is expected new commercial and industrial development will take place. The future electricity demand due to expected development in Hambantota area in the next 15 years assessed by Ceylon Electricity Board is given below.

i. Hambantota Harbor Project	- 20MVA
ii. Enhancement of existing Industrial Park (BOI), Mirijjawila	- 10 MVA
iii. Salt related Projects (BOI), Mirijjawila	- 1 MVA
iv. Oil refinery, Mirijjawila	- 5 MVA
v. Special Economic Zone at Meegahajandura	- 20 MVA
vi. Electricity Supply to Hambantota New Town	- 10 MVA
vii. Enhancement of Electricity needs of Existing Town Centre	- 4 MVA
viii. Airport, Udamattala	- 5 MVA

Total predicted load is 75 MVA by 2020.

With comparison and study of the different solar technologies and different solar plants operating presently in the world, it is understood that 20MW tower type CSP power plants are being operated successfully [5]. Next stage is the commercial level development of 50MW tower type CSP power plants. It is expected that this will be achieved at least by the year 2013. Therefore it can be expected that 50MW plants will be developed to its optimum level in 2020. It is expected 200MW plants will appear at least in 2020 [4]. Therefore by the year 2020 central receiver type CSP power plants will mature enough and will play comfortably in the market.

Hence considering all above facts it is decided to specify a 50MW tower type CSP power plant.

## 5.2. The Methodology of Conceptual Design

The designing of the plant was started from the electrical output of the plant. From there onwards, efficiency values and/or losses of major components were used to determine the energy flow of the plant. Determination of values of some parameters was done according to available literature. Design equations used in this chapter except 5.10 were obtained from “Power from the Sun” by William B. Stine and Michael Geyer, 2001.

Moreover, a spread sheet model developed by National Renewable Energy Laboratory (NREL), United States Department of Energy, which can be used for analyzing and comparing power system costs and performance of solar technologies, was also used for economic evaluation.

## 5.3. Plant Features and Design Calculations

The plant is a central receiver type solar thermal plant with molten salt storage. A simple schematic diagram of the plant is given in figure 5.1. The nominal electrical power output of the plant is 50 MW. The steam generator, the condenser, the turbine and the generator are considered as one unit for the ease of calculations. All the efficiency values unless otherwise stated are obtained from “Assessment of Parabolic Trough and Power Tower Solar Technology Cost and Performance Forecasts” by Sargent & Lundy LLC Consulting Group, Chicago for NREL in 2003. The values obtained are those forecasted for 2020.

The electrical efficiency (turbine-generator) = 42.80%

Thermal Storage Efficiency = 99.50%

Piping efficiency = 99.90%

Parasitic (Aux. power) efficiency = 90.00%

Plant-wide availability = 94.00%

∴ Thermal to electric efficiency = 42.80% x 99.90% x 90.00% x 94.00% x 99.50%  
= 35.99%



The rate of heat energy that should be provided by the receiver to steam generator to produce 50 MW electrical power output can be calculated as,

$$= 50 \text{ MW} / 35.99\%$$

$$= 138.92 \text{ MW}$$

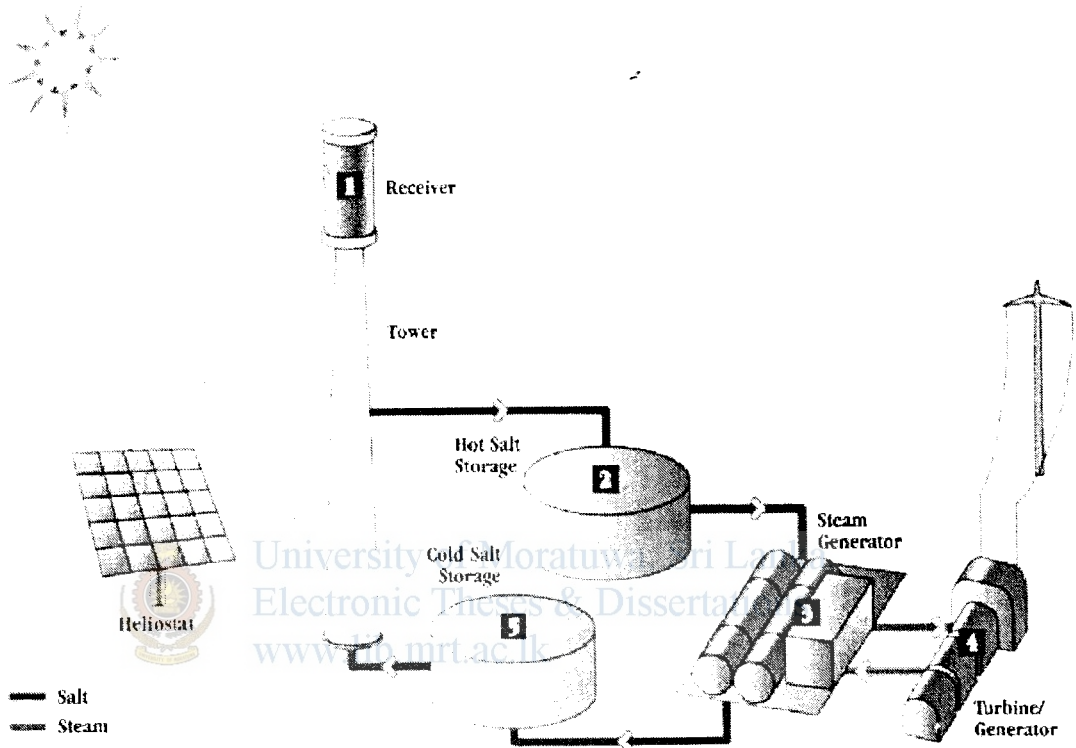

Figure 5.1: A simple schematic diagram of a power tower with a molten salt storage

In a typical installation, solar energy collection occurs at a rate that exceeds the maximum required to provide steam to the turbine. Consequently, the thermal storage system can be charged at the same time that the plant is producing power at full capacity. The ratio of the receiver's design thermal output to the power block's design thermal input is called solar multiple [10]. This value shall be determined by the hourly solar resource pattern. However, since we do not have hourly weather data of Tanamalwila and since it requires sophisticated analysis techniques, an average value is taken for calculations.

$$\text{Solar Multiple} = \frac{\text{Receiver's Design Thermal Output}}{\text{Power Block's Design Thermal Input}} \quad (5.01)$$

Solar multiple	= 1.4
Power to the storage	= (1.4 - 1) x 138.92 MW = 55.568 MW
Total receiver output	= 138.92 + 55.568 MW = 194.488 MW
Receiver Efficiency [4]	= 80.90%
Total Receiver input	= 194.49 ÷ 0.809 MW = 240.405 MW
Collector Field Efficiency [4]	= 56.50%
Total Solar insolation on heliostats	= 240.405 ÷ 0.565 MW = 425.49 MW

### 5.3.1. Design of Heliostats Field

The reflecting element of a heliostat is typically a thin, back surface, low-iron glass mirror. This heliostat is composed of several mirror module panels rather than a single large mirror. A perfectly flat heliostat would produce an image on the receiver; the size of the heliostat increases by approximately 0.5 degree of “sun-spread” [10]. The thin glass mirrors are supported by a substrate backing to form a slightly concave mirror surface. Individual panels on the heliostat are also inclined towards a point on the receiver. This produces a higher flux density at the aim point. The heliostat focal length is approximately equal to the distance from the receiver to the furthest heliostat. Subsequent “tuning” of the closer mirrors is possible [10].

The most critical environmental design criterion of a heliostat design is the wind speed. Typical requirements may be for the heliostat to meet its operating requirements in a 12 m/s wind, to survive a 22 m/s wind, and to continue to operate or move to the stow position in a 40 m/s wind [10]. According to available digital weather data obtained from the EnergyPlus program for Hambantota the average daily wind speed of Hambantota is less than 20 m/s. The wind speed has exceeded 40 m/s speed twice during a year. As wind speed of Tanamalwila area has lower than that of

Hambantota it can be considered the wind conditions in Tanamalwila area is suitable for available heliostat designs.

$$\begin{aligned}
 \text{Annual Average DNI at Tanamalwila [6]} &= 5 \text{ kWh/m}^2/\text{day} \\
 \text{Number of hours which sunlight is received} &= 12 \text{ hrs} \\
 \text{Average insolation} &= 5 \times 3600 \div (12 \times 3600) \\
 &= 0.4167 \text{ kW/m}^2 \\
 \text{Required Field Area (Heliostats - reflective)} &= 425.50 \text{ MW} \div 0.4167 \text{ kW/m}^2 \\
 &= 1,021,094 \text{ m}^2 \\
 \text{Ratio of Reflective Area to Heliostat Profile} &= 97\% \\
 \text{Area of a heliostat [4]} &= 148 \text{ m}^2 \\
 \therefore \text{Required number of heliostats} &= 1,021,094 \text{ m}^2 \div (148 \text{ m}^2 \times 97\%) \\
 &= 7,113 \text{ Nos.}
 \end{aligned}$$

### 5.3.2. Design of the Heliostat Field Layout

Optimum positioning of heliostats relative to the receiver is a complicated problem, in which costs and heliostat "loss" mechanisms are the variables. The collector field efficiency or loss happens due to number of reasons. They are cosine effect, shadowing, blocking, reflectance and atmospheric attenuation [4], [10].

$\therefore$  Field efficiency [10],

$$\eta_{field} = \eta_{cos} \cdot \eta_{shadow} \cdot \eta_{block} \cdot \eta_{reflection} \cdot \eta_{attenuation} \quad (5.02)$$

#### 5.3.2.1. Cosine Effect

The major factor determining an optimum heliostat field layout is the cosine "efficiency" of the heliostat. This efficiency depends on both the sun's position and the location of the individual heliostat relative to the receiver. The heliostat is positioned by the tracking mechanism so that its surface normal can bisect the angle between the sun's rays and a line from the heliostat to the tower. The effective reflection area of the heliostat is reduced by the cosine of one-half of this angle [10]. This may be visualized by considering heliostats at two positions in a field as shown on Figure 5.2. Heliostat 'A' has a small cosine loss since its surface normal is almost pointing toward the receiver. Heliostat 'B' has a larger cosine loss because of the

position it must assume in order to reflect the sun's rays onto the receiver. Note that the most efficient heliostats are located opposite the sun.

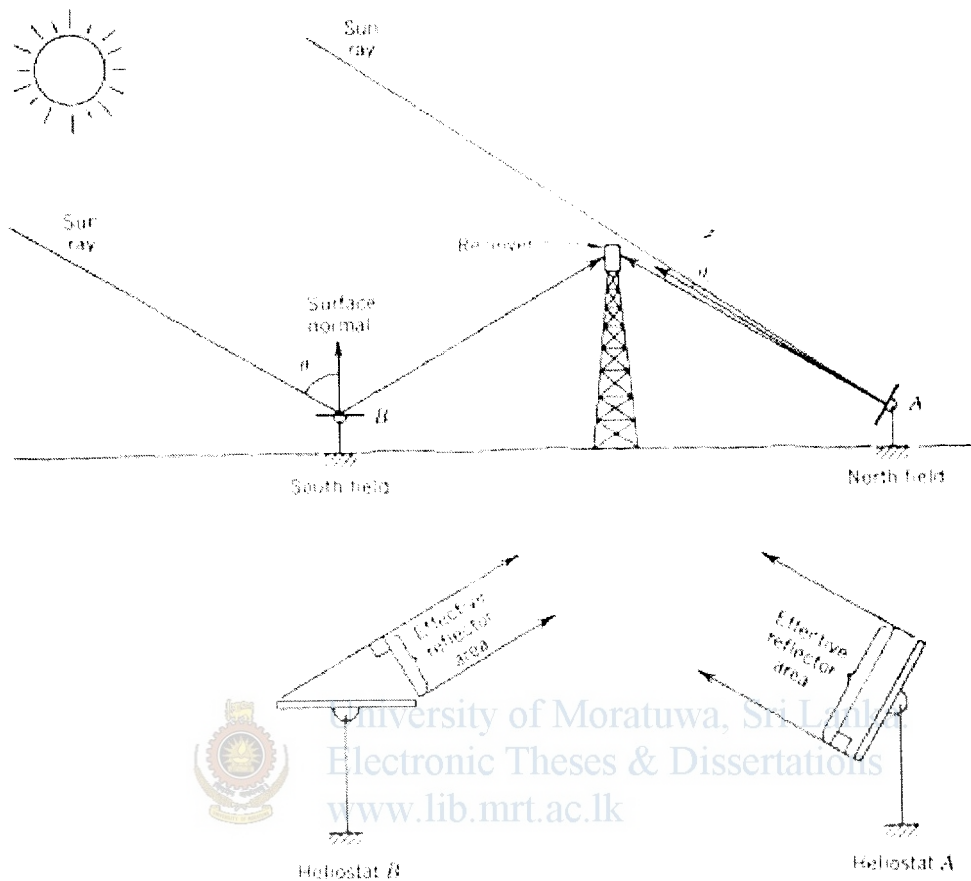

Figure 5.2: Cosine effect

Hence,  $Cosine\ loss = Cos\ \theta_i$

To calculation of  $Cos\ \theta_i$  can be done by following equation [10],

$$Cos\ 2\theta_i = \frac{(Z_o - Z_1)Sin\ \alpha - e_1Cos\ \alpha Sin\ A - n_1Cos\ \alpha Cos\ A}{[(Z_o - Z_1)^2 + e_1^2 + n_1^2]^{1/2}} \quad (5.03)$$

where  $\alpha$  and  $A$  are the sun's altitude and azimuth angles, respectively, and  $z$ ,  $e$ , and  $n$  are the orthogonal coordinates from a point on the tower at the height of the heliostat mirrors as depicted in Figure 5.3.

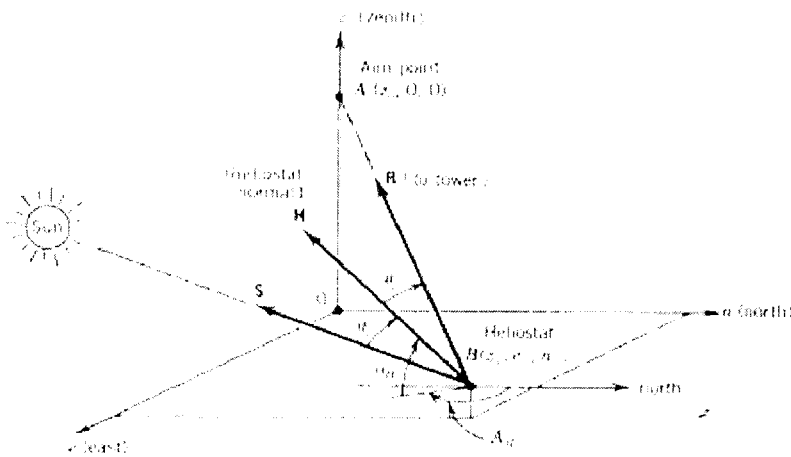

Figure 5.3: Azimuth Angle  $A$  and Altitude  $\alpha$

Approximate annual average efficiency values of them are given below.

Accordingly heliostats opposite the sun are the most efficient. This is why most of the heliostats in a typical heliostat field will be north of the tower if the power plant is situated on the northern hemisphere of the globe. In the morning, heliostats west of the tower will have a high efficiency and those of east of the tower, a poorer efficiency. The opposite occurs in the afternoon, giving the east and west fields an average efficiency in between the high and the low.

The cosine efficiency contours plotted by Matlab program at Tanamalwila site (Longitude:  $81^\circ$ , Latitude:  $6.5^\circ$ ) on 12.00 noon on 20<sup>th</sup> March which is the time having maximum altitude angle of  $80.416^\circ$  and azimuth angle of  $181.1^\circ$  to the sun is given in figure 5.4. The azimuth angle and altitude angle were calculated using equations given in Appendix C. The Matlab code is given in Appendix B. Tower height and height to the heliostat mirror are taken as 170m and 7m.

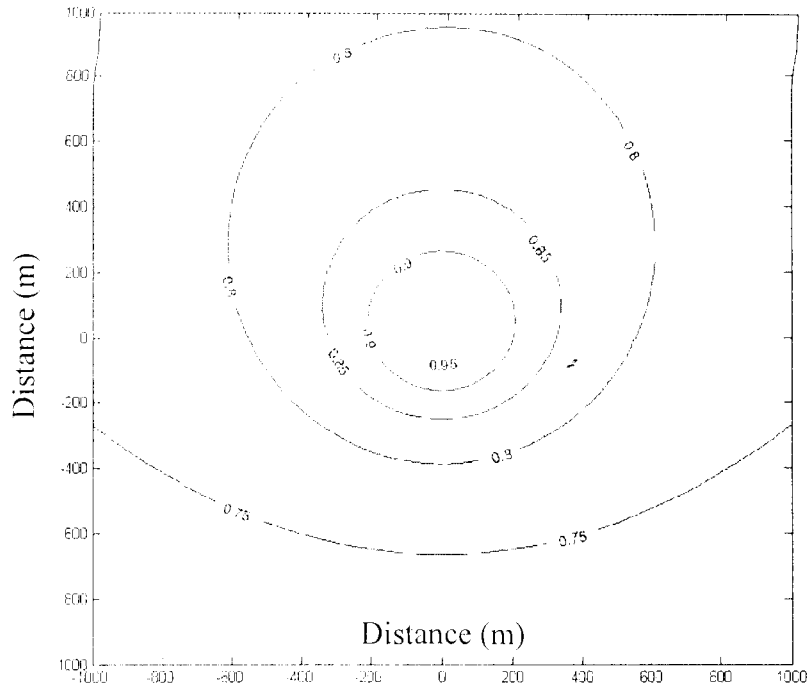

Figure 5.4: Cosine efficiency at Tanamalwila site at 12.00 noon on 20<sup>th</sup> March

Annual average cosine efficiency of a typical power tower is about 23.40 % [10]. However the annual average cosine efficiency map is different from that of a particular time.

### 5.3.2.2. Shadowing & Blocking

According to the arrangement of heliostats the problem of one collector casting a shadow on an adjacent collector can happen and thereby the energy output of the shaded collector can be reduced. In central receiver systems, there are two such interaction processes that reduce the amount of energy reaching the receiver. These are shadowing and blocking by adjacent heliostats.

Shadowing occurs at low sun angles when a heliostat casts its shadow on a heliostat located behind it. Therefore, all the incident solar flux doesn't reach the reflector. Blocking occurs when a heliostat in front of another heliostat blocks the reflected flux on its way to the receiver. Blocking can be observed in a heliostat field by noting reflected light on the backs of heliostats [10].

The solar energy loss caused by shadowing and blocking in a particular field layout is a function of the heliostat spacing, tower height, and sun angle. Optimum field layouts are made by use of extensive computer analysis.

Annual average shadowing & blocking loss is about 5.60 % [10].

### 5.3.2.3. Reflectance

Reflectance is the mirror reflectivity of the heliostats, the percentage of incident solar energy reflected to receiver.

Annual average reflectance loss is about 10% which means 90% of the incident solar energy on heliostats is reflected back to receiver [6], [10].

### 5.3.2.4. Atmospheric Transmittance

When the number of heliostats increases with the scaling up of the plant, the distance to far end of the field should be increased. One major limitation on the distance, that is, heliostat placed away from the tower may cause attenuation of the reflected beam as it travels from the heliostat to the receiver.

Atmospheric transmittance has been approximated for a clear day (23 km visibility) and a hazy day (5 km visibility). For a clear day with 23 km visibility, the atmospheric transmittance is given by following equation [10].

$$\tau_a = 0.99326 - 0.1046 S + 0.017 S^2 - 0.002845 S^3 \quad (5.04)$$

Where, S is the slant range from heliostat to receiver in kilometers.

For a hazy day with only 5 km visibility, the atmospheric transmittance is given by following equation [10].

$$\tau_a = 0.98707 - 0.2748 S + 0.03394 S^2 \quad (5.05)$$

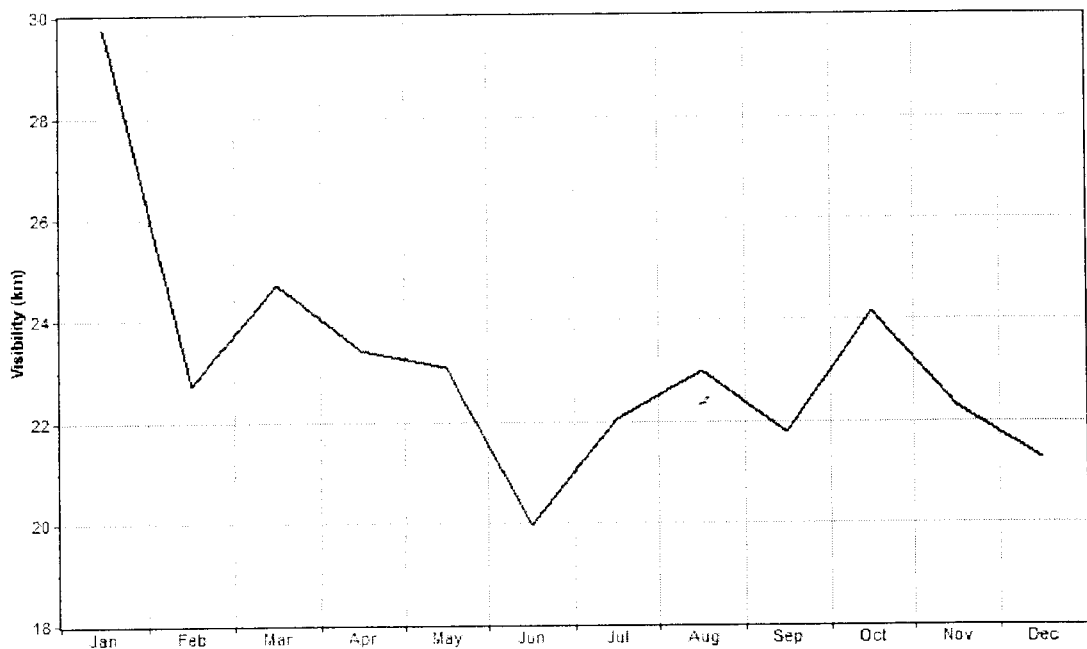

Figure 5.5: Average monthly visibility at Hambantota

Annual average atmospheric attenuation of a central receiver type power plant is about 6% [10]. However this value is dependent on the climate of the area in which the plant is located. The average monthly visibility in kilometer at Hambantota has higher values which are more than 20km [7]. This is a very good climatic condition for a central receiver type power plant.

### 5.3.2.5. Field Layout

Most commonly accepted pattern to arrange heliostats is the radial stagger pattern as shown in Figure 5.6. This arrangement minimizes land usage as well as shadowing and blocking losses. The heliostats are tightly packed near the tower but must be sufficiently separated from each other to prevent mechanical interference.

For heliostats located farther from the tower, the spacing increases in order to minimize blocking of the reflected beams. Additional heliostats are added when spacing becomes too great. And as a result, a new stagger pattern is established.

Heliostat packing density is the ratio of mirror area to field area. The average heliostat packing density is typically in the range of 0.20 to 0.25 [10].



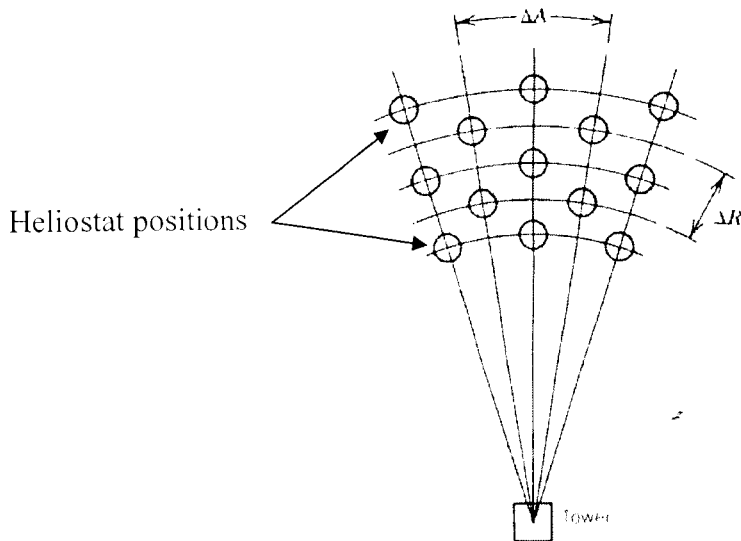

Figure 5.6: Radial Stagger pattern

The spacing between heliostats and average field density for preliminary field layouts which are arranged by radial stagger pattern can be found by following equations [10].

$$\Delta R = HM (1.44 \cot \theta_L - 1.094 + 3.068 \theta_L + 1.1256 \theta_L^2) \quad (5.06)$$

$$\Delta A = WM (1.749 + 0.6396 \theta_L) + \frac{0.2873}{\theta_L - 0.04902} \quad (5.07)$$

The radial spacing is  $\Delta R$  and the azimuthal spacing is  $\Delta A$ , as depicted in Figure 5.6.  $HM$  and  $WM$  are the height and width of the heliostat, respectively as shown in Figure 5.6. The angle  $\theta_L$  is the altitude angle to the receiver from the heliostat location of interest. And  $\theta_L$  can be calculated as follows [10].

$$\theta_L = \tan^{-1} \frac{H}{r} \quad (5.08)$$

Where,  $r$  is the distance along the ground from the tower to the heliostat location measured in "tower heights."

The local field density is the ratio of mirror area to land area at a particular point in the field. This can be obtained from the following equation [10].

$$P_F = \frac{2DM WM HM}{\Delta R \Delta A} \quad (5.09)$$

DM is the mirror density, which can be defined as the ratio of mirror area to overall heliostat area. The typical value of DM is 97% [10].

Heliostats pattern was computed for three different tower heights, 150m, 170m and 200m. The heliostats are arranged around towers on circles. The circle number, distance to the circle from the tower and relevant number of heliostats belonging to that particular circle are shown in the table 5.1.

Circle No.	Distance from the Tower	Heliostats per Circle	Cumulative No. of Heliostats	Circle No.	Distance from the Tower	Heliostats per Circle	Cumulative No. of Heliostats
Circle 01	50.0	10	10	Circle 29	422.1	105	1444
Circle 02	58.5	12	22	Circle 30	442.4	111	1555
Circle 03	67.3	14	36	Circle 31	463.4	116	1671
Circle 04	76.5	16	52	Circle 32	485.3	122	1793
Circle 05	86.0	18	70	Circle 33	508.0	128	1921
Circle 06	95.9	20	90	Circle 34	531.6	134	2055
Circle 07	106.1	22	112	Circle 35	556.2	141	2196
Circle 08	116.6	25	137	Circle 36	581.8	148	2344
Circle 09	127.4	28	165	Circle 37	608.4	155	2499
Circle 10	138.5	30	195	Circle 38	636.2	162	2661
Circle 11	149.9	33	228	Circle 39	665.1	169	2830
Circle 12	161.7	36	264	Circle 40	695.3	177	3007
Circle 13	173.7	39	303	Circle 41	726.8	185	3192
Circle 14	186.1	42	345	Circle 42	759.6	194	3386
Circle 15	198.8	46	391	Circle 43	793.9	202	3588
Circle 16	211.8	49	440	Circle 44	829.7	211	3799
Circle 17	225.2	52	492	Circle 45	867.1	220	4019
Circle 18	239.0	56	548	Circle 46	906.1	230	4249
Circle 19	253.2	60	608	Circle 47	947.0	240	4489
Circle 20	267.7	64	672	Circle 48	989.7	250	4739
Circle 21	282.8	68	740	Circle 49	1034.3	260	4999
Circle 22	298.3	72	812	Circle 50	1081.0	271	5270
Circle 23	314.2	76	888	Circle 51	1129.8	282	5552
Circle 24	330.7	81	969	Circle 52	1180.9	294	5846
Circle 25	347.8	85	1054	Circle 53	1234.4	305	6151
Circle 26	365.4	90	1144	Circle 54	1290.4	317	6468
Circle 27	383.6	95	1239	Circle 55	1348.992	329	6797
Circle 28	402.5	100	1339	Circle 56	1410.337	336	7133

Table 5.1: Heliostats layout design results for tower height of 180m

When the heliostats are farther from the tower, the radial spacing increases significantly, whereas the azimuthal spacing decreases to the point where the heliostats at a particular radial distance have one heliostat width between them ( $\Delta A = 2$ ). Figure 5.8 shows the decrease in local field density as distance from the tower increases.

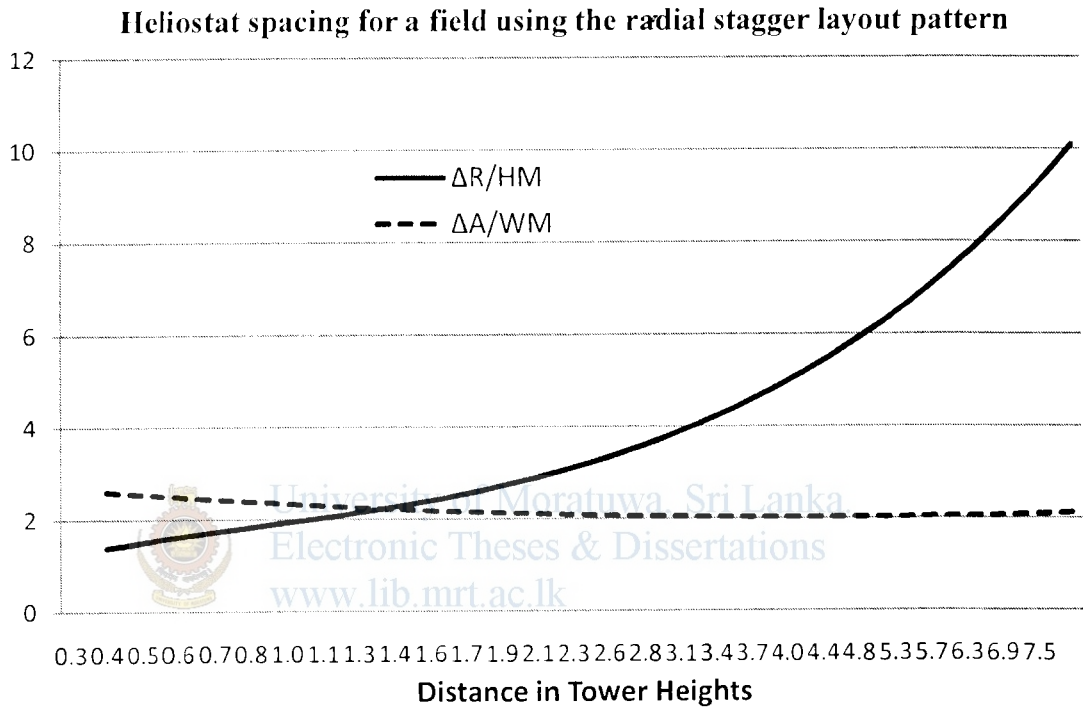

Figure 5.7: Radial and azimuthal spacing Vs. Distance

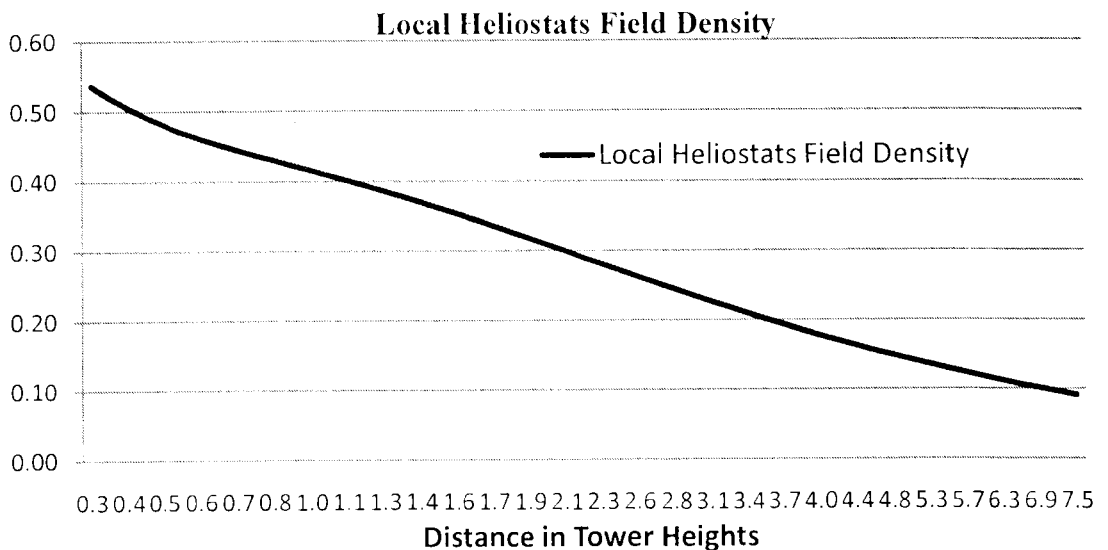

Figure 5.8: Local heliostat field density

### 5.3.2.6. Tower Height

The distance to the farthest line of heliostats for different tower height is given below.

Tower Height	150 m	170 m	180 m	200 m
Distance to the farthest line of heliostats	1708.02 m	1486.88 m	1410.34 m	1299.44 m

Table 5.2: Distance to farthest line of heliostats

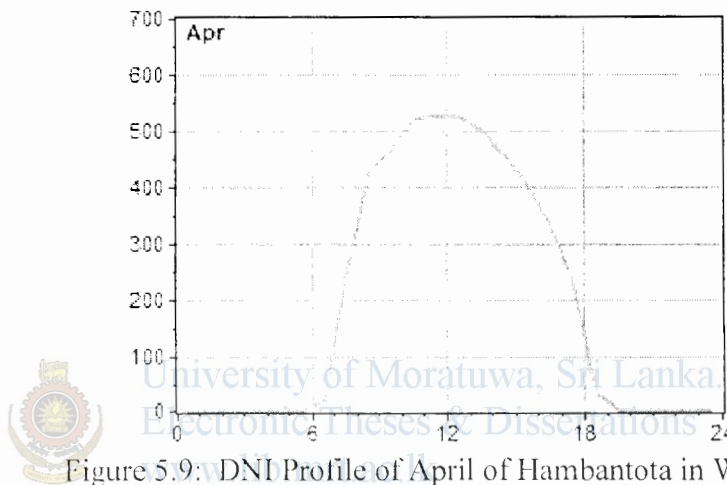

Figure 5.9: DNI Profile of April of Hambantota in Wh/m<sup>2</sup>

Month	Jan	Feb	Mar	Apr	May	Jun	Jul	Aug	Sep	Oct	Nov	Dec
Peak DNI Wh/m <sup>2</sup> (A)	550	600	650	525	550	450	500	525	500	550	450	490
Average Monthly DNI Wh/m <sup>2</sup> (B)	190	214	229	196	191	167	180	194	181	193	150	174
(A)/(B)	2.89	2.80	2.84	2.68	2.88	2.69	2.78	2.71	2.76	2.85	3.00	2.82
Average (A)/(B) = 2.81												

Table 5.3: The ratio between Peak DNI of a day to Average DNI of a day

The optimum tower height was taken as 180 m considering following graph as the peak thermal power of the plant is,  $194.5 \times 2.81 = 546.5$  MW. Peak to average DNI is

about 2.81 as shown in table 5.3. Peak thermal power means the maximum thermal power that enters the thermal unit from the receiver.

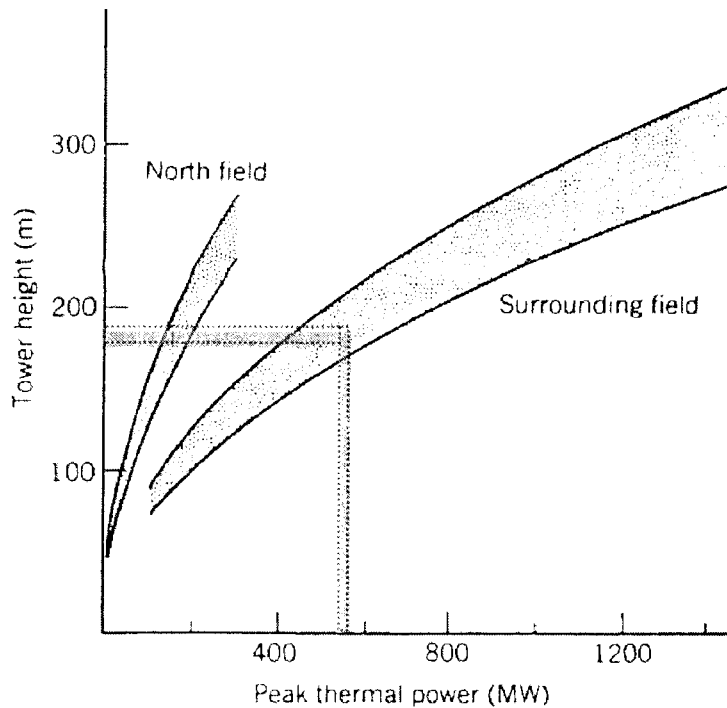

Figure 5.10: Range of optimum receiver tower heights for systems with different power levels [10]

### 5.3.2.7. Atmospheric Transmittance in Tanamalwila Site

The atmospheric transmittance of Tanamalwila site for heliostat layout design developed for tower height of 180 m is given in figure 5.11. When heliostat fields become larger the effect of atmospheric transmittance on overall efficiency becomes higher. The average atmospheric transmittance of Tanamalwila site is approximately 0.9185 which is computed by following formula.

$$\text{Average Atmospheric Transmittance} = \frac{\sum_{n=1}^N \tau_n \cdot H_n}{\sum_{n=1}^N H_n} \quad (5.10)$$

Where,  $\tau_n$  is the atmospheric transmittance of circle number  $n$   
 $H_n$  is the total number of heliostats in circle  $n$   
 $N$  is the total number of heliostat circles

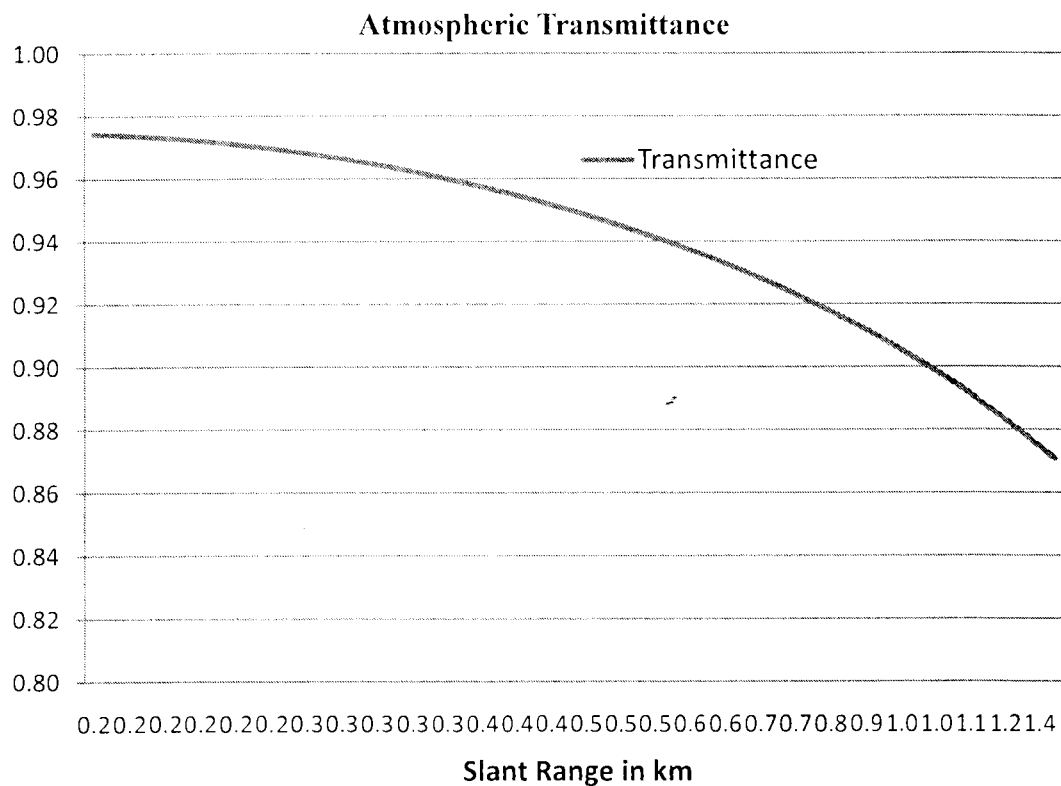

Figure 5.11: Atmospheric Transmittance at Tanamalwila



University of Moratuwa, Sri Lanka.  
Electronic Theses & Dissertations  
www.lib.mrt.ac.lk

### 5.3.3. Design of the Receiver

The receiver is located at a prominent point on the tower top so that reflected energy from the heliostats can be intercepted most efficiently. The receiver absorbs the energy being reflected from the heliostat field and transfers it into a heat transfer fluid (HTF). There are two basic types of receivers: external and cavity. External Receivers consist of panels of many small (20-56 mm) vertical tubes welded side by side to approximate a cylinder. The bottoms and tops of the vertical tubes are connected to headers that supply HTF to the bottom of each tube and collect the heated fluid from the top of the tubes. External receivers typically have a height to diameter ratio of 1:1 to 2:1. The main limitation on receiver design is the heat flux that can be absorbed through the receiver surface and into the HTF, without overheating the receiver walls or the heat transfer fluid within them. The average flux over the entire absorber wall is typically one-half to one-third of these peak values. It is expected to use an external type receiver which is more suitable for a 50 MW plant. To avoid overheating of the receiver surface it is adopted 50% of peak flux which can be sustained by the receiver surface as design peak flux [10].

Receiver peak flux of molten salt in tubes [10]	= 0.7 MW/m <sup>2</sup>
Safety factor	= 0.5
Design peak flux	= 0.7 MW/m <sup>2</sup> x 0.5 = 0.35 MW/m <sup>2</sup>
Total receiver input	= 240.405 MW
Receiver size	= 686.88 m <sup>2</sup>
Take receiver diameter as	= 12 m
Receiver height	= 686.88 m <sup>2</sup> ÷ (π x 12 m) = 18.22 m
Height to diameter ratio (1 ~ 2)	= 1.52

∴ The dimensions of the receiver are ok.

#### 5.3.4. Design of the Storage

The use of energy storage in solar thermal energy systems is to shift excess energy produced during times of high solar availability to times of low solar availability. Two situations exist in solar energy system design where energy storage may be needed; for the situation in which some of the solar thermal energy produced during the day is stored to use later during the night, and to provide energy during events such as cloudy days.

The determination of the HTF to be pumped through the receiver is to be determined by the application. The criteria are maximum operating temperature of the system followed closely by the cost-effectiveness of the system and safety considerations. Steam, nitrate salt, liquid sodium or air is used as HTF. The HTF to be used in the design is nitrate salt, a mixture of 60% of NaNO<sub>3</sub> and 40% of KNO<sub>3</sub> [10]. They have a good storage potential because of their high volumetric heat capacity. The cost of nitrate salt mixtures is also lower, making them an attractive HTF candidate.

Heat storage capacity of molten salt [11]	= 2,710 kJ/m <sup>3</sup> °C
Receiver output temperature [4]	= 574 °C

Receiver input temperature [4] = 290 °C  
 Temperature rise in the receiver = 284 °C  
 Energy absorption per m<sup>3</sup> of HTF = 2,710 kJ/m<sup>3</sup> °C x 284 °C  
 = 769.64 MJ

No of full storage hours = 16 hrs  
 Total energy required in storage = 8,001,839 MJ  
 Required HTF volume = 10,396.86 m<sup>3</sup>

Storage tank diameter = 25 m  
 Storage tank height = 21.18 m

Density of molten salt  
 (NaNO<sub>3</sub> - 60% KNO<sub>3</sub> -40%) [11] = 1772 kg/m<sup>3</sup>  
 Required Heat Transfer Fluid (HTF) amount = 10,396.86 m<sup>3</sup> x 1772 kg/m<sup>3</sup>  
 = 18,423.23 Mt

Time required to achieve full storage = 8,001,839 MJ ÷ (55.568 MW x 3600)  
 = 40 hrs

Total System efficiency [4] = 16.45%

### 5.3.5. Thermal Performance

The thermal performance of a central receiver system can be defined in terms of overall system efficiency. It is common to define this efficiency in terms of the direct normal solar irradiance  $I_{b,n}$  and the total surface area of all of the heliostats in the field. The overall energy collection efficiency of a central receiver system can be worked out as follows [10].

$$\eta_{Col} = \frac{\dot{Q}_{Useful}}{I_{b,n} n_h A_h} \quad (5.11)$$

Where  $\dot{Q}_{Useful}$  is the rate of energy addition to the working fluid (measured at the bottom of the receiver tower),  $n_h$  is the total number of heliostats in the field, and  $A_h$



is the total area of the heliostat (based on outside dimensions, not the reflective portion).

$$\eta_{Col} = \frac{194,488,000 \text{ W}}{(416.7 \text{ Wm}^{-2}) \cdot (7133) \cdot (148 \text{ m}^2)}$$

$$\eta_{Col} = 44.2\%$$



University of Moratuwa, Sri Lanka.  
Electronic Theses & Dissertations  
[www.lib.mrt.ac.lk](http://www.lib.mrt.ac.lk)

# Chapter 06

---

## ENVIRONMENTAL IMPACTS

### 6.1. Impact on Environment in General

It is said the main environmental impact of CSP technology is 'land use'. For a new central receiver type power plant, new high-voltage transmission lines and associated facilities may be required. The range of environmental impacts associated with construction, operation, and decommissioning of this plant as well as transmission lines and facilities will also be taken into consideration.

A number of environmental factors have been identified for the consideration in a CSP project. For example, solar power plants can reduce the environmental impacts associated with combustion in fossil fuel power generation such as greenhouse gases and other air pollution emissions. However, concerns have been raised over several types of environmental impacts that could be associated with solar energy development, such as land disturbance, visual impacts, and the use of potentially hazardous materials in some solar systems.

For example, all utility-scale solar energy facilities require relatively large areas for solar radiation collection when used to generate electricity at a commercial scale. The large arrays of solar collectors may interfere with natural sunlight, rainfall, and drainage, which could have a variety of effects on plants and animals. Also, because they are generally large facilities with numerous highly geometric and sometimes highly reflective surfaces, solar energy facilities may create visual impacts. Central tower systems typically use conventional steam plants to generate electricity; these plants commonly consume water for cooling. As Tanamalwila area is an arid area, the increased water demand could strain available water resources. These environmental considerations, as well as impacts to wildlife, cultural resources, socio-economics and

other areas shall be addressed in the environmental impact assessment. Potential measures that can be implemented to avoid or mitigate impacts shall also be identified.

## 6.2. Minimization of Land Use Impacts

According to the available 'land use' data of GsT Homer geo-spatial kit, most of the lands of selected site are not agricultural or forest lands. However these lands can be used for agriculture if the lands are effectively irrigated. The possibility of growing of low height cultivations is studied below.

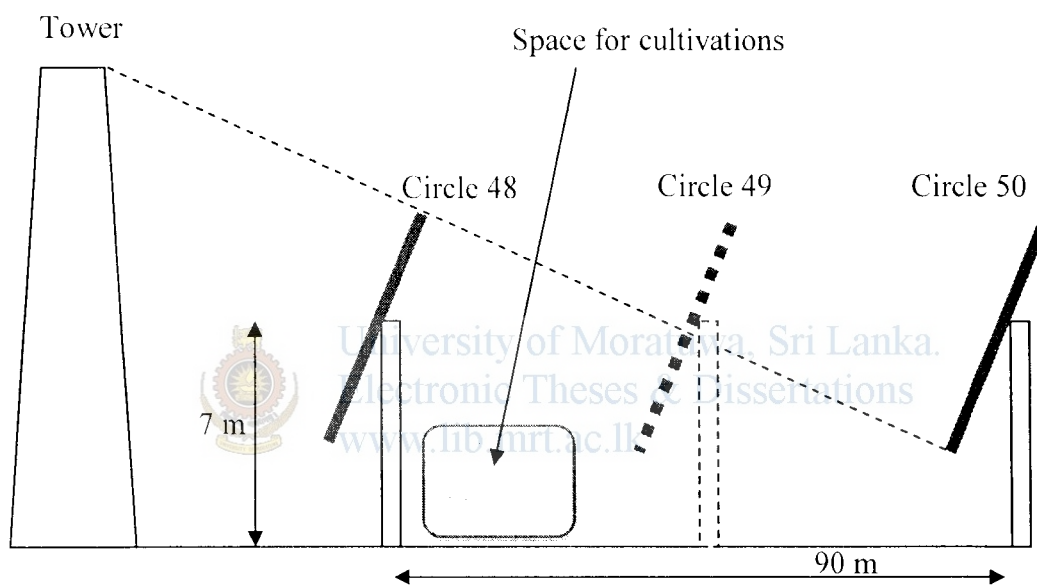

Figure 6.1: A Space for Cultivations

Consider the designed heliostats field layout for tower height of 180 m. The distance between heliostats circle 48 and 50 is about 90 m. The heliostat circle 49 does not obstruct heliostats in circle 50. The distance between heliostat circle 48 and 49 is about 44 m. However there should be enough space between heliostat circles for a cleaning vehicle. After leaving 5 m space for a cleaning vehicle and 10 m for maintenance access, still there is a space of 29 m. The available space is 29 m wide and at least 4 m height after leaving a considerable space above. Accordingly this space can be used to cultivate plants shorter than 4m in a 29 m strip around the heliostat circle 48.

It is clear that most of the dry zone cultivations can be grown in the above space. Enough space is available after heliostat circle 20. The estimated space that can be used for cultivations is about 350 ha out of total land requirement of 624 ha. That is 56% of total land requirement.

### 6.3. Displacement of CO<sub>2</sub>, NO<sub>x</sub> and SO<sub>2</sub> Emissions

The main advantage in terms of environment of central receiver power plant is the displacement of Carbon Dioxide and other hazardous emissions to the environment. It is calculated the displacement of Carbon Dioxide emission compared to a coal power plant, assuming it will displace a coal power plant in the future.

Capacity factor of the plant, assume	⇒ 50 %
Plant size	⇒ 50 MW
Energy generated per year	⇒ 50 x 0.50 x 365 x 24 x 1000 ⇒ 219,000,000 kWh
CO <sub>2</sub> per kWh <sup>1</sup>	⇒ 0.963 kg
Total CO <sub>2</sub> displacement	⇒ 0.963 x 219,000,000 kg ⇒ 210,897 Metric Ton
NO <sub>x</sub> per kWh <sup>2</sup>	⇒ 0.00014 kg
Total NO <sub>x</sub> displacement	⇒ 0.00014 x 219,000,000 kg ⇒ 30.66 Metric Ton
SO <sub>2</sub> per kWh <sup>2</sup>	⇒ 0.00034 kg
Total SO <sub>2</sub> displacement	⇒ 0.00034 x 219,000,000 kg ⇒ 74.46 Metric Ton

<sup>1</sup> [www.wikipedia.org](http://www.wikipedia.org)

<sup>2</sup> [http://en.citizendium.org/wiki/Conventional\\_coal-fired\\_power\\_plant#\\_note-MIT](http://en.citizendium.org/wiki/Conventional_coal-fired_power_plant#_note-MIT)

# Chapter 07

## ECONOMIC ANALYSIS

### 7.1. Cost Estimation

The estimation of costs was carried out using midterm (2010) and long term (2020) cost projections developed by Sargent & Lundy LLC Consulting Group, Chicago, Illinois in 2003 for NREL.

The estimation of Tanamalwila 50 MW central receiver type power plant for 2010 midterm cost projections is given below [4]. It is taken as case 01.

Description	Per Unit Cost In USD	Size	Costs (USD)
Structures and Improvements	3.9 \$/m <sup>2</sup> field	1,021,094 m <sup>2</sup>	3,982,266.60
Heliostat Field	134 \$/m <sup>2</sup> field	1,021,094 m <sup>2</sup>	136,826,596.00
Receiver	30.631 \$/m <sup>2</sup>	686.88 m <sup>2</sup>	21,039.82
Tower and Piping	8.7 \$/m <sup>2</sup> field	1,021,094 m <sup>2</sup>	8,883,517.80
Thermal Storage	41 \$/kWt	2,222,730 kWt	91,131,930.00
Steam Generator	8 \$/kWt	138,920 kWt	1,111,360.00
Electric Power	306 \$/kWe	50,000 kWe	15,300,000.00
Balance of Plant	367 \$/kWe	50,000 kWe	18,350,000.00
<b>Total Direct Installation Cost</b>			<b>275,606,710.22</b>

Table 7.1: Midterm Cost Estimations of Tanamalwila 50 MW Power Tower

The estimation of Tanamalwila 50 MW central receiver type power plant for 2020 long term cost projections is given below [4]. It is taken as case 02.

Description	Per Unit Cost In USD	Size	Costs (USD)
Structures and Improvements	2.7 \$/m <sup>2</sup> field	1,021,094 m <sup>2</sup>	2,756,953.80
Heliostat Field	117 \$/m <sup>2</sup> field	1,021,094 m <sup>2</sup>	119,467,998.00
Receiver	23.834 \$/m <sup>2</sup>	686.88 m <sup>2</sup>	16,371.10
Tower and Piping	9.1 \$/m <sup>2</sup> field	1,021,094 m <sup>2</sup>	9,291,955.40
Thermal Storage	40 \$/kWht	2,222,730 kWt	88,909,200.00
Steam Generator	7 \$/kWt	138,920 kWt	972,440.00
Electric Power	231 \$/kWe	50,000 kWe	11,550,000.00
Balance of Plant	169 \$/kWe	50,000 kWe	8,450,000.00
<b>Total Direct Installation Cost</b>			<b>241,414,918.30</b>

Table 7.2: Long term Cost Estimations of Tanamalwila 50 MW Power Tower

The balance-of-plant costs include general balance-of-plant equipment, condenser and cooling tower system, water treatment system, fire protection, piping, compressed air systems, closed cooling water system, instrumentation, electrical equipment, and cranes and hoists.

It can be seen the highest cost of the plant is the cost of heliostats field of 41.66% of the total cost. The other highest cost component is the thermal storage cost which amounts to 31% of the total cost.

The percentages of estimated costs components for case 02 (long term) are given below as a pie chart.

**Power Tower Costs in Percentages**

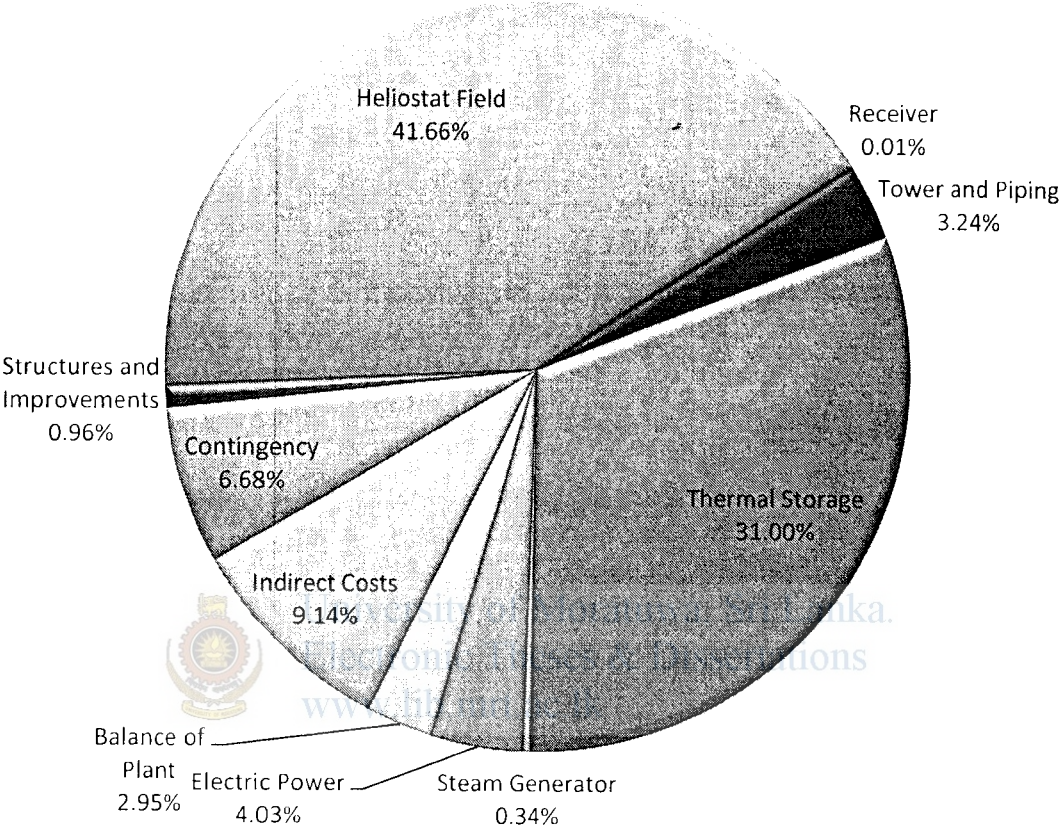

Figure 7.1: Power tower costs in percentages for long term estimation

**7.2. Estimation of Annual Energy Output**

The capacity factor is the ratio of the system's predicted electrical output in the first year of operation to the output had the system operated at its nameplate capacity [12],

$$CF = \frac{E_{OutputYear1}}{P_{SystemCapacity}} .8760 \tag{7.01}$$

Where,

CF Capacity factor.

$E_{\text{OutputYear1}}$	The total annual electric generation in the first year of operation,
$P_{\text{SystemCapacity}}$	The system's rated capacity expressed in kilowatts
8760	Number of hours in a year

It is assumed that the capacity factor equals to 50%. Accordingly the total annual electric generation in the first year of operation is 219 GWh.

### 7.3. Evaluation of Economic Feasibility

Economic evaluation was carried out by a spread sheet program which is developed to perform economic evaluations for solar thermal power plants which is available at NREL website. The input parameters used to evaluate case 01 and case 02 are given in table 7.3. The analysis was carried out in US dollar terms.

<b>Input Parameters for Economic Evaluation</b>	<b>Case 01</b>	<b>Case 02</b>
<b>General</b>		
Analysis Period	30 yrs	30 yrs
Inflation Rate	2.50%	2.50%
Real Discount Rate	4.00%	4.00%
<b>Taxes and Insurance</b>		
State Tax	7.5%	7.5%
Sales Tax	0%	0%
Insurance	0.50%	0.50%
<b>Loan</b>		
Loan (Debt) Percent	40.00%	40.00%
Loan Term	20 yrs	20 yrs
Loan Rate	4.00%	4.00%



<b>Power Purchase Agreement</b>		
PPA Escalation	1.0%	1.0%
<b>Constraining Assumptions</b>		
Minimum Required IRR	15.00%	15.00%
<b>Costs</b>		
Capital (Direct) Cost	\$275,606,710.22	\$241,414,918.30
Contingency	10.00%	10.00%
Total Capital (Direct) Cost	\$303,167,381.24	\$265,556,410.13
Engineering, Procurement & Construction	15.00%	15.00%
Project, Land, Other	10.00%	10.00%
Total Indirect Cost	\$75,791,845.31	\$66,389,102.53
Total Installed Cost	<b>\$378,959,226.55</b>	<b>\$331,945,512.66</b>
Variable O&M (\$/MWh)	\$8.00	\$6.00
Variable O&M Real Escalation	1%	1%
<b>Performance Based Incentives (PBI)</b>		
Carbon Credit cost saving <sup>1</sup>	0.03 \$/kWh	0.03 \$/kWh
<b>Energy Production</b>		
First Year Annual Output (kWh)	219,000,000	219,000,000

Table 7.3: Input Parameters for Economic Evaluation

<sup>1</sup> Emission factor for coal was taken as 0.963 kg/kWh and Carbon price as 32 USD per metric ton.

Following assumptions were made while the economic evaluation was carried out.

- It is assumed that the project is carried out by an IPP.
- It was assumed that the project will be a BOI approved project so that 15 year tax exemptions could be obtained. Therefore 30% tax that should be applied for rest of the 15 year was applied for full period of 30 years reducing it to 7.5% as spread sheet model accepts only a single tax rate for the whole period.
- It was assumed that a soft loan having 4% loan rate and a loan period of 20 years could be obtained from Global Environment Fund (GEF) or from World Bank as they are already providing soft loans for solar thermal projects.
- It was assumed that minimum required IRR is 8% as it is the typical value for such projects.
- It was assumed a power purchase agreement can be made with Ceylon Electricity Board with an escalation rate of 1% per year.
- It was assumed capacity factor of 50% for the evaluation.
- It was assumed the project could obtain the benefit of carbon credit program and the Carbon price as 0.03 \$/kWh which is the current price for such projects.



University of Moratuwa, Sri Lanka.  
Electronic Theses & Dissertations  
www.lib.mrt.ac.lk

The final results of the economic evaluation are given in the table 7.4.

<b>Final Results of Economic Evaluation</b>	<b>Case 01</b>	<b>Case 02</b>
Real LCOE (USD cents/kWh)	10.15	8.55
Nominal LCOE (USD cents/kWh)	13.58	11.44
First Year PPA (USD cents/kWh)	12.25	10.32
Installation cost per kW (USD)	7,579.2	6,638.9

Table 7.4: Final Results of Economic Evaluation

Accordingly if the above assumptions are correct the project becomes an economically viable project.

The after tax net equity cash flow for case 02 is given below for 30 year analysis period.

Year	After Tax Net Equity Cash Flow	Year	After Tax Net Equity Cash Flow
0	(199,167,307.60)	16	17,432,581.54
1	14,865,342.78	17	17,594,952.22
2	15,040,921.65	18	17,755,608.29
3	15,216,215.76	19	17,914,420.52
4	15,391,154.61	20	18,071,254.47
5	15,565,664.66	21	27,996,023.13
6	15,739,669.28	22	28,177,785.90
7	15,913,088.58	23	28,358,306.74
8	16,085,839.32	24	28,537,475.58
9	16,257,834.80	25	28,715,178.06
10	16,428,984.71	26	28,891,295.41
11	16,599,195.00	27	29,065,704.25
12	16,768,367.76	28	29,238,276.47
13	16,936,401.05	29	29,408,879.07
14	17,103,188.78	30	29,577,373.93
15	17,268,620.57		

Table 7.5: After Tax Net Equity Cash Flow in USD

#### 7.4. Sensitivity Analysis

Considering above two analyses as base cases, a sensitivity analysis is done. All the LCOE values are in USD cents per kWh.

The variation of LCOE against different capacity factors is given below.

Capacity Factor (CF)	Total Annual Electric Generation	Case 01		Case 02	
		Real LCOE	Nominal LCOE	Real LCOE	Nominal LCOE
0.3	131,400,000.00	18.05	24.15	15.47	20.70
0.4	175,200,000.00	13.11	17.54	11.14	14.91
0.5	219,000,000.00	10.15	13.58	8.55	11.44
0.6	262,800,000.00	8.17	10.93	6.82	9.12
0.7	306,600,000.00	6.76	9.04	5.58	7.47
0.8	350,400,000.00	5.70	7.62	4.65	6.22

Table 7.6: LCOE vs. Capacity Factor

The variation of LCOE against different real discount rates is given below.

Real Discount Rate	Case 01		Case 02	
	Real LCOE	Nominal LCOE	Real LCOE	Nominal LCOE
3.5%	10.10	13.62	8.51	11.47
4%	10.15	13.58	8.55	11.44
6%	10.33	13.42	8.71	11.30
8%	10.50	13.28	8.85	11.19
10%	10.65	13.17	8.98	11.09

Table 7.7: LCOE vs. Real Discount Rate

The variation of LCOE against minimum required IRR is given below.

Minimum Required IRR	Case 01		Case 02	
	Real LCOE	Nominal LCOE	Real LCOE	Nominal LCOE
4%	7.05	9.43	5.85	7.83
6%	8.54	11.43	7.15	9.57
8%	10.15	13.58	8.55	11.44
10%	11.83	15.83	10.02	13.40
15%	16.27	21.77	13.90	18.59

Table 7.8: LCOE vs. Minimum Required IRR

The variation of LCOE against the availability of Carbon Credit Facility is given below.

Availability of Carbon Credit	Case 01		Case 02	
	Real LCOE	Nominal LCOE	Real LCOE	Nominal LCOE
0.030 USD per kWh	10.15	13.58	8.55	11.44
0.015 USD per kWh	11.39	15.24	9.79	13.10
Without carbon credit	12.63	16.90	11.03	14.76

Table 7.9: LCOE vs. Availability of Carbon Credit

The variation of LCOE against the loan term is given below.

Loan Term (Years)	Case 01		Case 02	
	Real LCOE	Nominal LCOE	Real LCOE	Nominal LCOE
10	10.71	14.33	9.04	12.10
15	10.40	13.92	8.77	11.74
20	10.15	13.58	8.55	11.44

Table 7.10: LCOE vs. Loan Term

The LCOE if the BOI state is not given.

Availability of BOI State	Case 01		Case 02	
	Real LCOE	Nominal LCOE	Real LCOE	Nominal LCOE
With BOI State	10.15	13.58	8.55	11.44
Without BOI State	13.28	17.76	11.29	15.11

Table 7.11: LCOE vs. Availability of BOI state  

[www.lib.mrt.ac.lk](http://www.lib.mrt.ac.lk)  
 Electronic Theses & Dissertations

The variation of LCOE against PPA escalation rate is given below.

PPA Escalation Rate	Case 01		Case 02	
	Real LCOE	Nominal LCOE	Real LCOE	Nominal LCOE
1%	10.15	13.58	8.55	11.44
2%	10.23	13.69	8.62	11.53
3%	10.32	13.81	8.70	11.63

Table 7.12: LCOE vs. PPA escalation rate

It can be observed that the LCOE is more sensitive to capacity factor and minimum required IRR compared to other parameters. And the tax exemption for 15 years, which is received if the BOI state is given, has a considerable impact on the LCOE.

# Chapter 08

---

## CONCLUSIONS

It can be finally concluded that a 50MW central receiver type solar thermal power plant at Tanamalwila area is technically feasible with available solar resources. However an onsite DNI survey has to be carried out as the solar resources database is a modeled estimation.

When it comes to the economic feasibility, a 50MW central receiver type solar thermal power plant at Tanamalwila is economically feasible if the forecasted price reduction of central receiver type technology is decreased up to Sargent & Lundy report's long term price forecast.

And the Ceylon Electricity Board should accept a Power Purchase Agreement with the IPP for an electricity sales price begins from 10.32 cents USD/kWh and having an annual escalation rate of 1%.

Further, to make this project a reality, the project developers shall obtain a 20 year soft loan with a loan interest rate not exceeding 4% from an international development bank such as Global Environmental Facility (GEF), World Bank or Japan International Cooperation Agency (JICA). Further, Board of Investment (BOI) approval for 15 year tax holiday and 8% IRR are also crucial to produce electricity for 8.55 cents USD/kWh of real LCOE.

## REFERENCES

- [1] Soteris Kalogirou, "Solar Energy Engineering: Processes and Systems", Elsevier Publications, 2009.
- [2] Sorin Grama, Elizabeth Wayman and Travis Bradford, "Concentrating Solar Power - Technology, Cost, and Markets", Prometheus Institute and Greentechmedia, Cambridge, 2008
- [3] National Renewable Energy Laboratory, US Department of Energy web site: <http://www.nrel.gov>
- [4] Sargent & Lundy LLC Consulting Group, Chicago, "Assessment of Parabolic Trough and Power Tower Solar Technology Cost and Performance Forecasts", National Renewable Energy Laboratory, 2003.
- [5] Sandia National Laboratories, US Department of Energy web site : <http://www.energylan.sandia.gov/sunlab/>
- [6] Dave Renné, Ray George, Bill Marion and Donna Heimiller, "Solar Resource Assessment for Sri Lanka and Maldives", National Renewable Energy Laboratory and Chris Gueymard, Solar Consulting Services, 2003.
- [7] EnergyPlus weather data, US Department of Energy website, <http://apps1.eere.energy.gov>
- [8] Carlos Márquez Salazar, "An Overview of CSP in Europe, North Africa and Middle East", CSP Today, October 2008
- [9] Geospatial Toolkit: a map-based software application that integrates resource data and geographic information systems (GIS) developed by NREL for Sri Lanka
- [10] Stine and Michael Geyer, "Power from the Sun", 2001, available at <http://www.powerfromthesun.net>
- [11] Frank Kreith and D Yogi Goswami, "Handbook of Energy Efficiency and Renewable Energy", Crc Press, 2007

- [12] Solar Advisor Model (SAM) and spread sheet model developed by NREL for economic evaluation.
- [13] Hey whats that path profiler web site: [www.heywhatsthat.com/profiler.html](http://www.heywhatsthat.com/profiler.html)
- [14] Cédric Philibert, “The present and future use of solar thermal energy as a primary source of energy”, International Energy Agency, Paris, France
- [15] “Concentrating Solar Power for the Mediterranean Region”, German Aerospace Center (DLR), Institute of Technical Thermodynamics Section Systems Analysis and Technology Assessment



University of Moratuwa, Sri Lanka.  
Electronic Theses & Dissertations  
[www.lib.mrt.ac.lk](http://www.lib.mrt.ac.lk)



## APPENDIX – A

### Definitions for Economic Evaluation

Following definitions were extracted from the user guide of Solar Advisor Model (SAM) software developed by NREL.

#### A.1 Utility Independent Power Producer (IPP)

When the project is implemented by a utility IPP the project earns revenues through electricity sales at a fixed or escalating annual rate determined through a power purchase agreement to cover project costs. The owner pays cash for the equity portion of the total installed cost in year zero of the cash flow, and makes an interest and principal payment in subsequent years. In the spread sheet it is calculated a first year power purchase price that meets internal rate of return.

#### A.2 Levelized cost of energy (LCOE)

The levelized cost of energy (LCOE) is the value that a power project must receive for each unit of electricity that it generates (or saves) to ensure that all costs are covered, and that a reasonable profit (or saving) is made. The LCOE is an economic measure that is useful for comparing and ranking technology options because it is a cost that accounts for the purchase, financing, tax, and operation costs of a power project over its lifetime. Analysts can use the LCOE to evaluate renewable energy projects and to compare them to energy efficiency and conventional fossil fuel projects, each with different project lifetimes and different performance characteristics.

$$LCOE = \frac{\sum_{n=1}^N \frac{R_{required,n}}{(1+d)^n}}{\sum_{n=1}^N \frac{Q_n}{(1+d)^n}}$$

$Q_n$	Electricity generated by the project in year $n$
$N$	Project life in years
$R_{required,n}$	Project revenue from electricity sales in year $n$ required to cover project costs
$d$	Discount rate

For the real LCOE, the real discount rate appears in the total energy output term:

$$Real\ LCOE = \frac{\sum_{n=0}^N \frac{R_{Required,n}}{(1 + d_{nominal})^n}}{\sum_{n=1}^N \frac{Q_n}{(1 + d_{real})^n}}$$

Similarly, for the nominal LCOE, the nominal discount rate appears in the total energy output term:

$$Real\ LCOE = \frac{\sum_{n=0}^N \frac{R_{Required,n}}{(1 + d_{nominal})^n}}{\sum_{n=1}^N \frac{Q_n}{(1 + d_{nominal})^n}}$$

The nominal discount rate,

$$d_{nominal} = (1 + d_{real})(1 + e) - 1$$

$d_{nominal}$	Nominal discount rate expressed as a fraction.
$d_{real}$	Real discount rate expressed as a fraction.
$e$	Inflation rate defined on the Financing page expressed as a fraction.

### A.3 Net Present Value (NPV)

The net present value is the present value of the after-tax cash flow discounted to year one using the nominal discount rate, plus the after-tax cash flow in year zero:

$$NPV = \sum_{n=1}^N \frac{C_n}{(1 + d_{nominal})^n} + C_o$$

$C_n$	The after-tax cash flow in year n.
$C_o$	The after-tax cash flow in year 0 of the project cash flow, equivalent to the principal amount displayed on the Financing page.

#### A.4 Internal Rate of Return (IRR)

The internal rate of return is the discount rate, IRR in the equation below, that corresponds to a project net present value, NPV, of zero,

$$NPV = \sum_{n=1}^N \frac{RequiredRevenue_n - AfterTaxCashFlow_n}{(1 + IRR)^n} + AfterTaxCashFlow_0$$

#### A.5 Some Other Important Definitions

Some important terminologies used in economic evaluation in the spread sheet is given below.

- **Analysis Period:** Number of years covered by the analysis. Typically equivalent to the project or investment life.
- **Inflation Rate:** Annual rate of change of prices, typically based on a price index. Solar Advisor uses the inflation rate to calculate costs in the cash flows for years after year one.
- **Real Discount Rate:** A measure of the time value of money expressed as an annual rate. Solar Advisor uses the real discount rate to calculate the present value (value in year one) of cash flows over the analysis period and to calculate annualized costs.
- **Minimum Required IRR:** The lowest value of the internal rate of return required for the project to be financially feasible. The internal rate of return is the discount rate that results in a project net present value of zero.
- **PPA escalation rate:** The PPA escalation rate is an annual escalation rate that uses to calculate future electricity sales prices based on the first year PPA price.
- **Loan Term:** Number of years required to repay a loan. Can be more or less than the analysis period.
- **Loan Rate:** Annual loan interest rate.

## APPENDIX – B

### Matlab Program to Plot Cosine Efficiency Contours

An M-file was prepared with the following code for the cosine efficiency contours of Tanamalwila site.

```
[X,Y]= meshgrid(-1500:50:1500,-1500:50:1500);  
Z = cos((acos(((170-7)*sin(1.45595)-  
X*cos(1.45595)*sin(3.14159)-  
Y*cos(1.45595)*cos(3.14159))./((170-7)^2+X.^2+Y.^2).^0.5))/2);  
[C,h] = contour(X,Y,Z);  
set(h,'ShowText','on','TextStep',get(h,'LevelStep'))
```



University of Moratuwa, Sri Lanka.  
Electronic Theses & Dissertations  
[www.lib.mrt.ac.lk](http://www.lib.mrt.ac.lk)

## APPENDIX – C

### Some Important Solar Related Technical Definitions

Following definitions are obtained from Soteris Kalogirou's "Solar Energy Engineering: Processes and Systems".

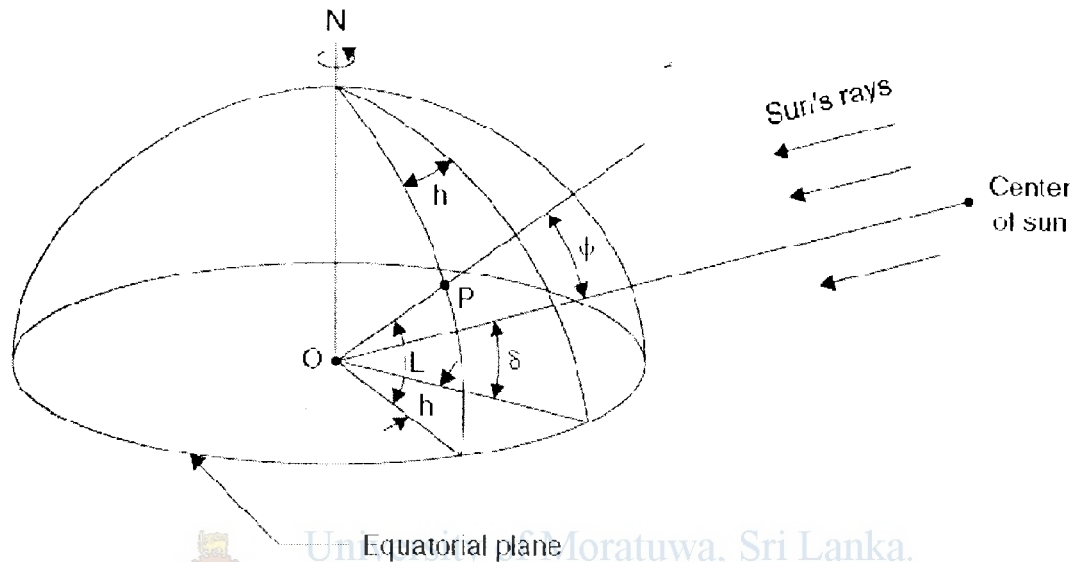

Figure c1: Declination angle and hour angle

#### C.1 The Declination Angle, $\delta$

The earth axis of rotation (the polar axis) is always inclined at an angle of  $23.45^\circ$  from the ecliptic axis, which is normal to the ecliptic plane. The ecliptic plane is the plane of orbit of the earth around the sun. As the earth rotates around the sun it is as if the polar axis is moving with respect to the sun. The solar declination is the angular distance of the sun's rays north (or south) of the equator, north declination designated as positive.

The declination,  $\delta$ , in degrees for any day of the year ( $N$ ) can be calculated approximately by the equation,

$$\delta = 23.45 \sin \left[ \frac{360}{365} (284 + N) \right]$$

### C.2 The Hour Angle, $h$

The hour angle,  $h$ , of a point on the earth's surface is defined as the angle through which the earth would turn to bring the meridian of the point directly under the sun. Above figure shows the hour angle of point P as the angle measured on the earth's equatorial plane between the projection of OP and the projection of the sun-earth center to center line.

$$h = \pm 0.25 \text{ (Number of minutes from local solar noon)}$$

Where, the plus sign applies to afternoon hours and the minus sign to morning hours.

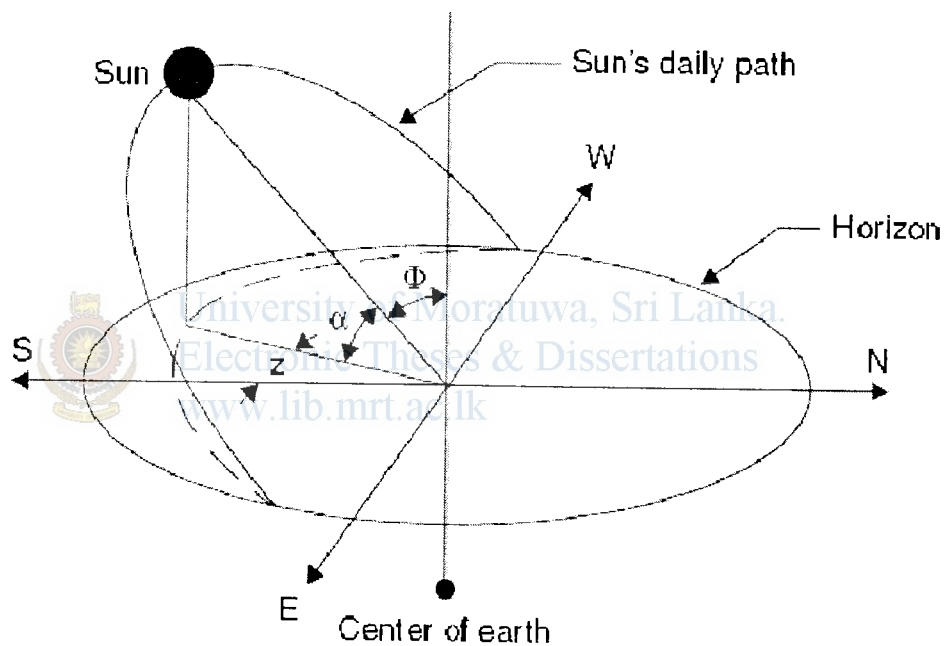

Figure c2: Altitude angle and azimuth angle

### C.3 The Solar Altitude Angle, $\alpha$

The solar altitude angle is the angle between the sun's rays and a horizontal plane, as shown in figure given above. It is related to the solar zenith angle,  $\Phi$ , which is the angle between the sun's rays and the vertical. Therefore,

$$\Phi + \alpha = \frac{\pi}{2} = 90^\circ$$

The mathematical expression for the solar altitude angle is,

$$\sin \alpha = \cos \Phi = \sin L \sin \delta + \cos L \cos \delta \cos h$$

Where,  $L$  is the local latitude, defined as the angle between a line from the center of the earth to the site of interest and the equatorial plane. Values north of the equator are positive and those of south are negative.

### **C.3 The Solar Azimuth Angle, $z$**

The solar azimuth angle,  $z$ , is the angle of the sun's rays measured in the horizontal plane from due south (true south) for the Northern Hemisphere or due north for the Southern Hemisphere; westward is designated as positive. The mathematical expression for the solar azimuth angle is,

$$\sin z = \frac{\cos \delta \sin h}{\cos \alpha}$$



University of Moratuwa, Sri Lanka.  
Electronic Theses & Dissertations  
[www.lib.mrt.ac.lk](http://www.lib.mrt.ac.lk)

## APPENDIX – D

The user interface of spreadsheet model used for economic evaluation developed by NREL to use with Solar Advisor Model (SAM) is given below. However the input values are obtained from manual calculations. The spreadsheet model can be downloaded from [www.nrel.gov/analysis/sam/support.html](http://www.nrel.gov/analysis/sam/support.html).

Results			
		First Year PPA (cents/kWh)	10.32
Real LCOE (cents/kWh)	8.55	Actual IRR	8.00%
Nominal LCOE (cents/kWh)	11.44	Actual Min DSCR	2.01
Values from SAM Inputs			
Financials			
General			
Analysis Period	30		
Inflation Rate	2.50%		
Real Discount Rate	4.00%		
Taxes and Insurance			
Federal Tax	0.00%	Capital (Direct) Cost	\$241,414,918.30
State Tax	7.50%	Contingency	10.00%
Property Tax	0.00%	Total Capital (Direct) Cost	\$265,556,410.13
Sales Tax	0.00%	Engineer, Procure, Construct	15.00%
Insurance	0.50%	Project, Land, Other	10.00%
Loan			
Amount Loan (Debt)	132,778,205.06	% of Direct Costs Sales Tax Applies	0.00%
Percent Term	40.00%	Total Indirect Cost	\$66,389,102.53
Rate	4.00%	Total Installed Cost	\$331,945,512.66
		Variable O&M (\$/MWh)	\$6.00
		Variable O&M Real Escalation	1.00%



Power Purchase Agreement			
PPA Escalation	1.00%		
Constraining Assumptions		Fixed (Annual) O&M (\$/yr)	\$0.00
Minimum Required IRR	8.00%	Fixed (Annual) O&M Real Esc.	0.00%
Positive Cashflow	yes	<b>Costs - Fixed Incentive/Buy-Downs</b>	
		Total Adjusted Installed Costs	\$331,945,512.66
<b>Values from Outputs</b>			
Results Page			
First Year Annual Output (kWh)	219,000,000.00	Includes effect of system derate factor.	
Intermediate Values			
Effective Tax Rate	7.50%		
Credit Basis - Fed	\$331,945,512.66	Depr. Basis - Fed	\$331,945,512.66
Credit Basis - State	\$331,945,512.66	Depr. Basis - State	\$331,945,512.66
Nominal Discount Rate	6.60%		



		Incentives	
Percent w/ Maximum	Fixed, Federal	%	\$
Percent w/ Maximum	Fixed, State	%	\$
Percent w/ Maximum	Fixed, Utility	%	\$
Percent w/ Maximum	Fixed, Other	%	\$
		Maximum	
	CBI, Federal	\$/W	\$
	CBI, State	\$/W	\$
	CBI, Utility	\$/W	\$
	CBI, Other	\$/W	\$
	ITC, Federal	\$	
	ITC, State	\$	
Percent w/ Maximum	ITC, Federal	%	\$
Percent w/ Maximum	ITC, State	%	\$
		Term	Escal.
	PTC, Federal	\$/kwh	years
	PTC, State	\$/kwh	years
	PBI, Federal	\$/kwh	years
	PBI, State	\$/kwh	years
	PBI, Utility	\$/kwh	years
	PBI, Other	\$/kwh	years
		30	1

Only inputs and summary of results are given above. Detailed outputs of the model, such as after tax cash flow, are not given above.