

APPLICATION OF 3D CFD MODEL TO ANALYSE THERMAL COMFORT OF AN UNDERGROUND BUILT ENVIRONMENT

CGS Gunasekara,
Kotmale Power Station, Ceylon Electricity Board, Mawatura, Sri Lanka
Email: csgsu@kth.se

Abstract

Kotmale underground hydro electric power generating station is the first ever built underground structure (hydro electric power station) in Sri Lanka, which was commissioned in 1988. This hydro power station is situated about 25 km south west of the central hill country main city Kandy, which has a tropical climate ambient temperature ranging from 20 Celsius to 30 Celsius during the dry season. Location of the hydro power station Cavern where the three 70 MW generators, turbines and other accessories are located is 250m below the ground level. The power station cavern is accessed through a 500m long tunnel to the underground. In a structure of this nature, it is important to keep the temperature and the air quantity in an acceptable range for the well being of the occupants. The ventilation to the power station cavern is provided through a forced air ventilation system which pumps air through a 250 m long tunnel from the top. The power station cavern itself consists of three floors, where ventilation air is distributed through a duct system which runs through the floors. But, according to the past experience, it has been noticed that the rate of ventilation or the air refreshing rate is insufficient for the thermal comfort and to maintain the air quality inside of this structure. Traditional methods of evaluating thermal comfort are not capable of analyzing the air flow path of a complex built structure of this nature. Hence, this paper discusses the application of a 3D CFD model to analyze and simulate the ventilation air flow path, in order to analyze the thermal comfort of this underground built environment to find out the issues related to thermal comfort and air quality of the system that affects to its occupants i.e. operators and maintenance staff. CD Adapco star CCM+ software was used for modelling and simulating the ventilation system.

Keywords: built environment, ventilation, air quality, thermal comfort, CFD, flow visualization, Simulation

1. Introduction

Thermal comfort is an important factor which affects to the health and the thermal comfort of occupants of a built environment. The fundamental of human thermal comfort is described and affecting parameters are defined in ASHRAE standards. Thermal comfort is a basic requirement that need to be addressed in a built environment design. ASHRAE standard defines ventilation requirement for an acceptable Indoor Air Quality (IAQ) for commonly occupied spaces such as, Offices, Public Spaces, Theatres, Hotels, etc (ASHRE 2001). But the thermal comfort under study in this paper is not a traditional space whose ventilation recommendations are clearly defined under ASHRAE. This under-ground hydro-power station has been constructed during 1980's, at the time where sophisticated thermal comfort analysis tools were not available. Indoor air temperature, mean radiant temperature relative humidity and air movement or air flow are the main parameters that affect to the thermal comforts of the occupants, Tang G Lee et al (2001). Kotmale Hydro Power Generating Station is a complex underground built environment. Using natural ventilation for a complex multilevel underground structure of the nature is not possible. Hence, a forced ventilation system has been employed in order to ensure the Indoor Air Quality (IAQ) and to maintain humidity; which is a property of temperature, by refreshing the indoor air by out-door air (ANSI/ASHRAE 55-1992). As defined by the ASHRAE in 1992, widely accepted definition for human thermal comfort is described as the state of mind, which expresses satisfaction with thermal environment (Bruel & Kjaer, 1996). This is very difficult to capture by measuring physical parameters involved with the system (Sustainable Environment – Vol. I). So that in an effective ventilation system, to maintain the heat balance and the desired temperature, a proper air distribution should be maintained through-out the entire system. Air flow path visualization as the concept to evaluate effectiveness of ventilation system and 3D CFD modelling as the tool for predicting air motion/airflow path have been used (User Manual, CD Adapco star CCM+ software).

2. Ventilation system

Kotmale Hydro Power Station is an under-ground hydro electric power generation station, located in the central hills of Sri Lanka. It is the first station of that kind in the country located about 500m above the mean sea level. It has an annual generating capacity of 300GWhr with an installed capacity of 201 MW (67x3 MW). It's power station which comprises of three generating units are located in a cavern three floors of 67x20x38 m³ in total size, 250 m below the ground level with a access tunnel of 500m long at the 1st floor level as shown in Fig 2.1 below (Maintenance manual Ceylon Electricity Board)

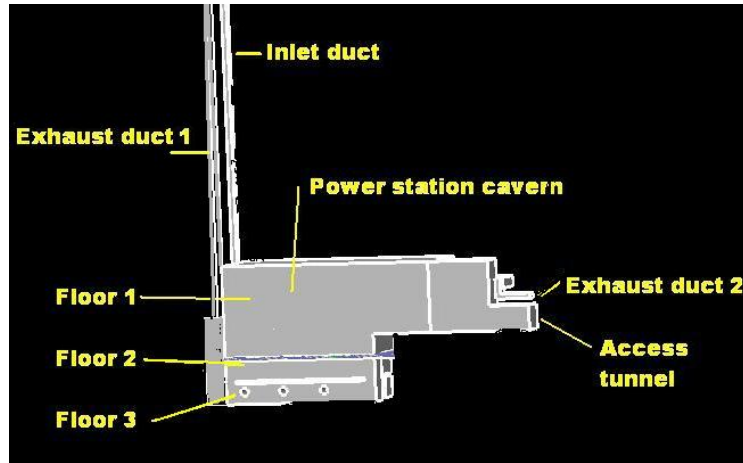

Fig 2.1 Layout of the ventilation system

2.1 Layout of the ventilation system

As this underground system ventilation is provided through a duct of 250 m length where air is taken from the switchyard located above the power station. This duct serves as the ventilation path as well as the path through which the output cables are taken out to the switchyard. Ventilation system consists of three main ducts one duct which supplies ventilation air from the ground level down to the power station cavern and other two serve as exhaust ducts (exhaust duct 1 & 2). Exhaust duct 1 is used to carry the generated electrical power to the switchyard through cables as well as to pump out the exhaust air. Heat generated in the power cables is absorbed by the exhaust air in order to maintain the cable temperature. Exhaust duct 2 pumps out the air to the access tunnel. The inlet duct supplies forced air flow through a ventilation duct as shown in Figure 2.1.

2.1.1 Forced air supply system

Ventilation air is supplied through a 250m long duct running from the switchyard down to the power station cavern. It has a cross section area of $1.0 \times 0.5 \text{ m}^2$. Details of the supply fan system is as given in table 2.1 below. Fig no 2.2b shows the configuration of the inlet duct system as modelled using Adepco star CCM+ design software.

Table 2.1: Air supply system characteristics

| | |
|----------------------------|------|
| Air flow m ³ /s | 0.7 |
| Pressure Pa | 250 |
| Fan speed rpm | 2820 |
| Motor power KW | 0.37 |

2.1.2 Air suction (exhaust) system

Supplied air is sucked through the exhaust duct system which has exhaust fan at the end of the duct and has the same characteristic as shown in table 2.1. Fig no 2.2a shows the location of the outlet duct system in the power station cavern and as modelled by the star plus design software. Specifications of air suction fans and duct are as given in Appendix 2.

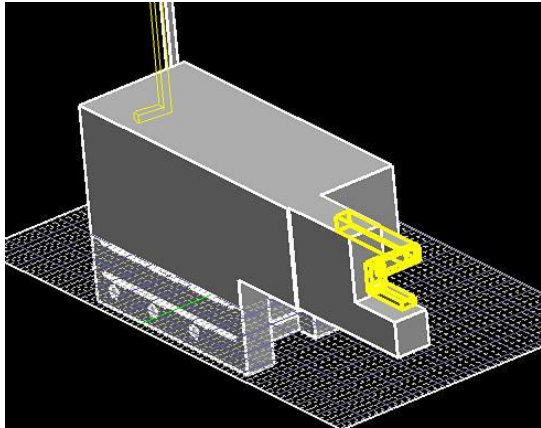

Fig 2.2a: Exhaust duct system

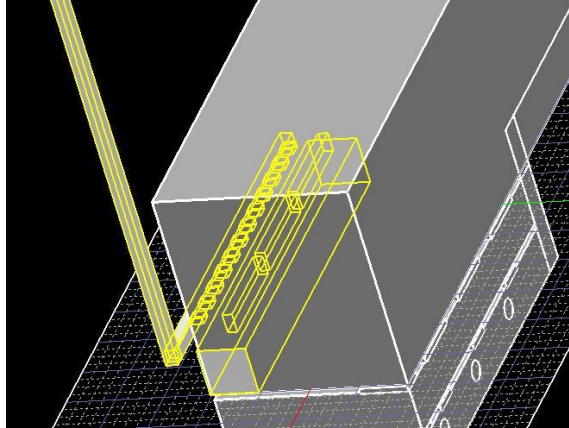

Fig 2.2b inlet duct system

3. Heat balance of the system

Three 67MW generators, high voltage cables and the control equipment panels as shown in Fig 3.1 act as the heat sources of the system except the heat generated by the occupants of the environment which is not significant compared to the above three main sources. Generated heat within the system is taken out by the circulation air flow supplied through the forced ventilation mechanism and sucked back through the forced outlet air ducts.

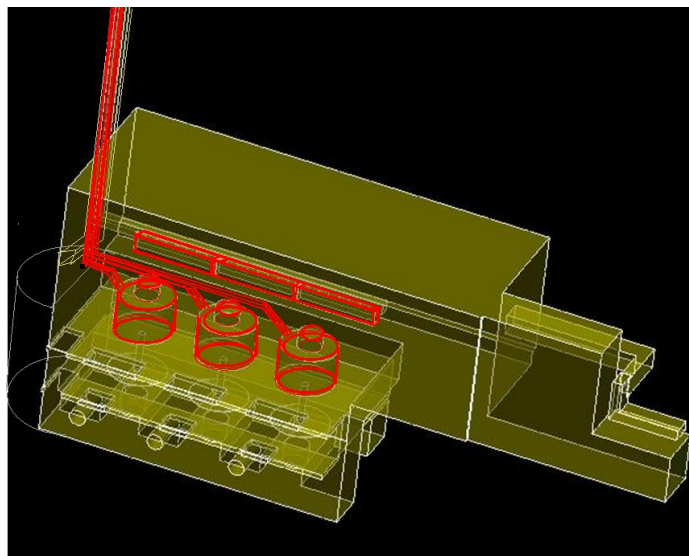

Fig 3.1 Heat sources of the system

4. Modelling the Ventilation System

4.1 Methodology used

CD Adapco star CCM+ design software package was used to model the power station ventilation system. Total system was decomposed in to 60 components as given in table 6.3 of the appendix 3. The three main components of the system are, underground power station cavern which consists of three floors. Generators, control cubicles, turbines, main inlet valve, draft tubes. They are modelled as blocks and cylinders as shown in appendix 3. Next two important components of the system are, inlet duct system which consists of the down running long duct from ground level and the horizontal duct which distributes the air to the power station cavern through twelve openings as shown in Fig 4.1 below.

Third important component of the system is the outlet or exhaust duct which pumps out the ventilation air supplied by the inlet. Fig no 4.1 shows the components of the out let duct system and its location in the power station cavern and the placement of the generators, control cubicles and main inlet valve and draft tube in the three floors respectively which act as obstacles to free air flow and the openings from floor 1 to floor 2 and opening from floor 2 to floor 3 which act as only air passages as there are no any other ventilation air paths provided to 2nd and 3rd floors in the form of ducts in the original design.

4.2 Assumptions made

Inside the control volume considered for this modelling and simulation there are some heat generating sources such as power cables, heat exchangers, motors, lighting and generators etc. During this modelling it was assumed that air flow was not disturbed by the heated surfaces and the effect to the air flow due to the boundary layer formation due to heated surfaces was neglected as an assumption and to simplify the model.

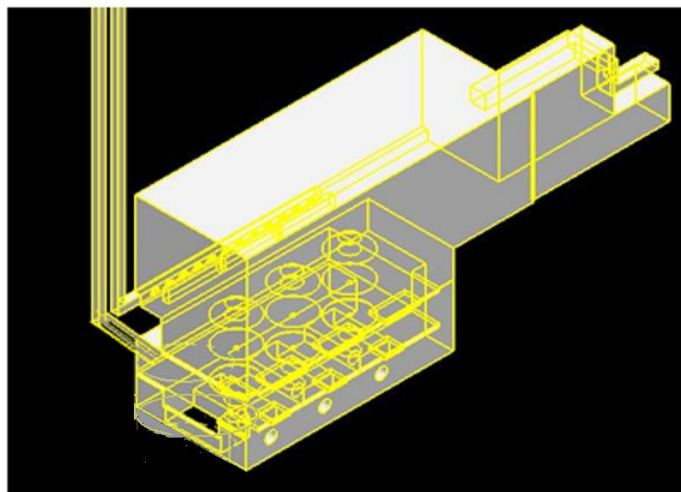

Fig 4.1 Model developed for simulation

4.3 Analysing the ventilation system

4.3.1 Developing the model

In order to model the ventilation system, the control volume of the system was considered as made up with main components. The inlet duct, power station cavern and outlet ducts. The cavern was made up of three components 1st floor, 2nd floor and 3rd floor. These three components and opening in between floors 1 and 2 and 2 and 3 were designed as blocks and added together using the unite facility given in the software (CD Adapco star CCM plus design). Then the obstacles to free air flow path i.e. control cubicles, generators, exciters, draft tube and main inlet valve were designed as block and cylinders and subtracted from the united model using the subtract facility of the design software.

4.3.2 Defining the pressure faces

Control volume of the model has three faces open to the inlet, outlet (exhaust) and to the atmospheric pressure (tunnel access). Pressures of the faces in the control volume were defined as follows shown in table 4.3.2.

Table 4.3.2. Pressure values (Pa)

| | |
|-------------------------------------|------|
| Pressure of inlet face | 250 |
| Pressure of access tunnel face | 100 |
| Pressure of exhaust duct 1,2 outlet | -250 |

5. Results

Results obtained by simulation are shown in fig 5.1, 5.2 and 5.3 for area near the exhaust duct 2 adjacent to the access tunnel and two views obtained for different profiles of the model inside the cavern which clearly shows the flow stream lines at the top left corner are shown below.

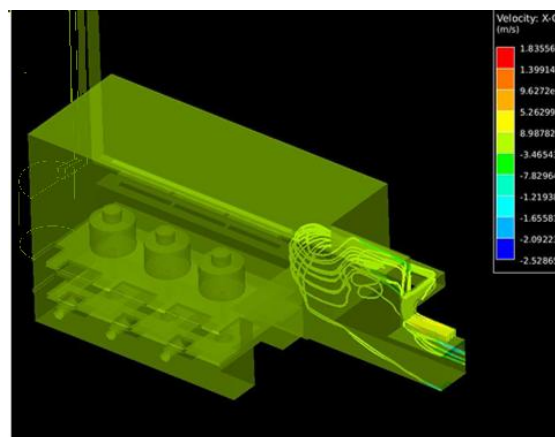

Fig 5.1 Stream lines at the tunnel outlet and exhaust outlet

As shown in Fig 5.2 exhaust air out fed back to inside the cavern through the access tunnel which creates a circulation path. This problem could have been avoided if the outlet duct extends up to the end of the access tunnel.

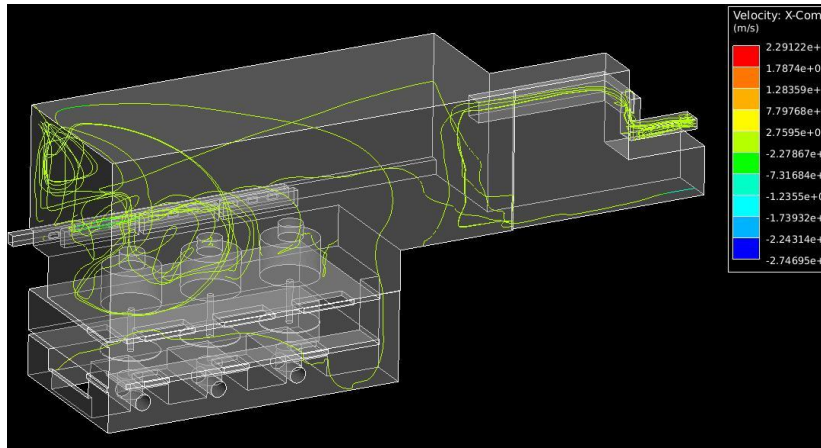

Fig 5.2: Air flow coming out from the inlet duct (along the line $X1=43, X2=5, Y1=Y2=-8.85, Z1=Z2=-71$) and distribution in the 1st 2nd and 3rd flow

As shown in Fig 5.2 and 5.3 in different angles, air flow coming out of inlet ducts form a circulation at the top left side of the cavern reducing the effectiveness of air distribution through out the building uniformly.

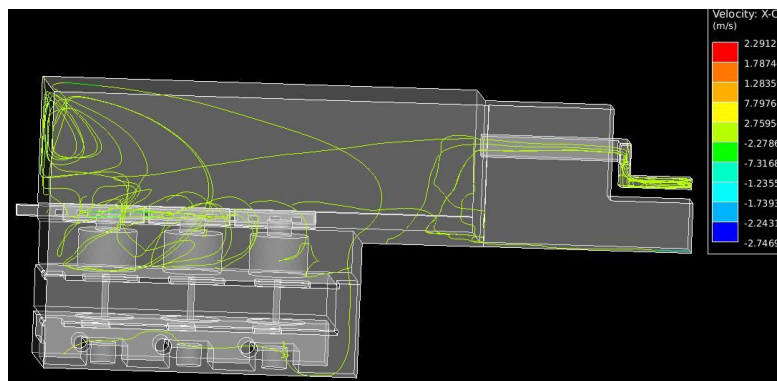

Fig 5.3: lines coming out from the inlet duct (along the line $X1=43, X2=5, Y1=Y2=-8.85, Z1=Z2=-71$) and distribution in the 1st, 2nd and 3rd flow

6. Conclusion

Generally a ventilation system is designed by optimizing the energy requirement of the ventilation mechanism. Hence, a slight reduction of the performance of the plant may badly affect the ventilation of entire building. From this 3D simulation of visualization of flow, it has been observed that several characteristics that badly affect to the distribution of ventilation air through-out the entire structure. As clearly shown in Fig. 5.1 according to the arrangement of the outlet exhaust duct, circulated air inside the cavern does not escape to the outside environment. It is fed back to the system while creating a short circuit path to the flow which ultimately does not remove the heat form the system as expected. As also shown in Fig 5.2 and 5.9 air circulation caused at the left upper part of the cavern affects the proper ventilation of the system. This model was developed only to demonstrate the

qualitative analysis of the flow path (flow visualization) and hence does not provide any quantitative analysis.

References

ASHRAE (2001), ASHRAE Fundamentals Handbook 2001, American Society of Heating, Refrigerating and Air Conditioning Engineers, USA, ISBN10: 1883413907.

Tang G Lee et al (2001), Health and the Built Environment, Indoor Air Quality, The Faculty of Environmental Design, University of Calgary, Alberta, Canada.

ANSI/ASHRAE 55-1992, ASHRAE Standard Thermal Environmental conditions for human occupancy, American Society of Health, Refrigerating and Air Conditioning Engineering Inc. Atlanta, GA 30329, ISSN 1041-2336.

Bruel & Kjaer (1996), Thermal Comfort, INNOVA Air Tech Instruments.

Sustainable Environment – Vol. I, Thermal Comfort in housing and thermal environments, Fairiborz Haghghat Department of Building Civil and Environmental Engineering, Concordia University, Montrial, Canada.

User Manual, CD Adapco star CCM+ software, (available on line http://www.cd-adapco.com/training/star_tutor.html [accessed on 18/12/2010])

Maintenance manual Ceylon Electricity Board, 1985, Kotmale power station, Svenska, Sweden.

Appendices

Appendix 1: Technical details of the ventilation system

Table 6.1: Specifications of the ventilation system (Source- Maintenance manual Ceylon Electricity Board, Kotmale power station, Svenska , Sweden 1985)

| | |
|---|----------------------------------|
| <i>Inlet vertical duct length</i> | <i>250 m</i> |
| <i>Inlet duct horizontal length</i> | <i>50 m</i> |
| <i>Outlet duct 1 length total</i> | <i>40 m</i> |
| <i>Outlet duct 2 length total</i> | <i>270 m</i> |
| <i>Inlet and outlet (exhaust) duct cross section area</i> | <i>1.0x0.5 m²</i> |
| <i>Air volume flow rate</i> | <i>0.7 m³/s</i> |
| <i>Air flow velocity (volume flow rate / cross section area)</i> | <i>0.7 / (1.0X0.5) = 1.4 m/s</i> |

Appendix 2: Technical Specification of the Ventilation Supply and exhaust fans

Table 6.2: Air supply exhaust fan details (source: Svenka, Maintenance manual)

| Fan type | Power KW | Pressure Pa | Air volume m ³ /s |
|-------------------|----------|-------------|------------------------------|
| Supply (SF1, SF2) | 0.37 | 250 | 0.7 |
| Exhaust (EF1) | 0.37 | -250 | 0.7 |

Appendix 3: Components of the model

Table 6.3: Components of the model

| Object No | Object Type | Description | Unite | Substract |
|-----------|-------------|--------------------------------------|-------|-----------|
| 1-3 | block | Floor 1,2,3 | y | |
| 4 | block | Cable duct | | y |
| 5 | block | Loading bay | | y |
| 6-8 | block | Opening to 2 nd floor | y | |
| 9 | block | Control room | | y |
| 10-11 | block | Opening to 2 nd floor | y | |
| 12-14 | cylinder | Generator 1, 2,3 | | y |
| 15 | block | Entrance 2 | y | |
| 16 | block | Entrance 3 | y | |
| 17-19 | block | Relay/instrumentation cubicles | | y |
| 20-23 | block | Opening to 3 rd floor | y | |
| 24-26 | cylinder | Turbine wicket gate space | y | |
| 27-29 | cylinder | shaft | | y |
| 30-32 | cylinder | Draft tube | | y |
| 33 | block | 3 rd floor concrete block | | y |
| 34-36 | block | Penstock block | | y |
| 37-39 | cylinder | Main Inlet Valve (MIV) | | y |
| 40 | block | Access tunnel | y | |
| 41 | block | 3 rd floor concrete block | | y |
| 42-45 | block | Outlet duct exhaust | y | |
| 46 | block | Inlet duct horizontal | y | |
| 47-60 | block | ventilation outlets | y | |