

# Mitigation of the Effects of Micro-Tremors on High Sensitive Facilities

Goguladas Yogeshwaran  
Structural Engineer,  
Central Engineering Consultancy Bureau, Sri Lanka.  
(email: [ykoguladas@yahoo.com](mailto:ykoguladas@yahoo.com))  
James Brownjohn  
Professor of Structural Dynamics,  
University of Sheffield, UK.  
(email: [james.brownjohn@sheffield.ac.uk](mailto:james.brownjohn@sheffield.ac.uk))

## Abstract

High technology industries that produce micro-electronic components and other facilities need extreme precision experimental measurements at sub-micron level. The current and future products continue to decrease in sizes and the technology used to make these products demands stringent vibration control environment. Design process of the facilities is the most promising method to achieve this stringent vibration control environment.

Automatic updating of finite element model was developed for simulating the effects of micro-tremors on a typical building: The model was employed for exploring the vertical response of floors under base excitation. The vertical responses of the floors in the building due to for an example ground vibration signal were obtained and converted to vibration criterion curve to compare with specific vibration acceptance criteria. The structural parameters were iterated until the required level of vibration control was achieved and the structural elements can be optimized.

**Keywords:** High Sensitive Facilities, Vibration Criterion, Response

# 1. INTRODUCTION

Miniaturizations of advanced integrated circuits push technology for economic mass production at nano-scale to greater challenges. These equipments and the high technology sensitive equipment used in the laboratories for the research and for production in fields such as metrology, biotechnology, medicine and micro/optic electronics, require an environment with stringent vibration control in the range of sub –micron level. This environment intercepts many external and internal sources vibration and there is considerable level of uncertainty when quantifying the sources. As this problem is case specific there are not enough guide lines, either empirically or analytically for exploring the dynamic effects of the facilities. Hence vibration serviceability has become a high-profile research during the design process in the proposed facility to achieve a vibration control environment.

The vibrations can be from number of sources. It is of critical importance to identify the possible sources of vibration for the design process of the vibration-sensitive structures. External sources like moving vehicles on a rough surface, underground rail service, pile driving at the construction or far field micro tremors and internal sources of moving lift, personal activities, rotating exhaust fan, air conditioner and extensive support machinery typically present in high technology facilities may produce unacceptably severe vibrations, unless mitigation of these vibrations is taken into account in the facility design.

This paper presents the dynamic response of a building evaluated subject to micro tremors by an automated finite element model. The response is posited in the form of one third octave curve and the curve is compared with generic vibration criteria. Subsequently if the response function does not meet the required vibration criteria, the structural parameters can be updated in the automated finite element model. Finally, the critical appraisal can be provided for future rational design of low rise sensitive facilities.

## 2 LITERATURE REVIEW

In addition to the conventional design, several key steps are involved in the design for vibration control. The degree of vibration control has to be dictated at the first step according to vibration serviceability requirements. The vibration response varies from location to location on a floor. However the sensitive equipments vacating on the floor demand different range of stringent control level, therefore the limit of permissible vibration criteria need to be drawn logically to satisfy each equipment on the same floor, where it can perform to full operational level within the established vibration limit. Manufacturers' specifications are nowadays based on generic vibration curve [VC]<sup>1</sup> shown in Figure 2.1. The severity of vibration environment is increasing from VC-A to VC-E. Building cost will increase with severity of VC requirement<sup>2</sup>. Massive structural elements may be needed to control the dynamic response lines with VC-E

compared to VC-A, therefore due to the sustainability concerned, the facilitators are in position to do serviceability check against VC.

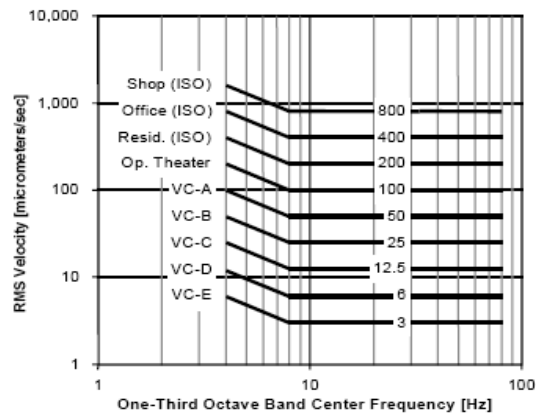

Figure 2.1 Generic Vibration Criterion (VC) Curves (Bayat A and Davis J.B, 2005)<sup>3</sup>

The vibration sensitive facilities has been configured from slab on grade to multi-storeyed building over the past decades<sup>4</sup> according to the availability of space and the interior design of the facilities. Slab-on grade is the best place to accommodate sensitive equipment as it will reduce the transmission and amplification of the vibration, being stiffly and uniformly supported by underlying soil<sup>5</sup>. It is noted that more stringent condition than VC-B is difficult to achieve on the upper floors<sup>6</sup>. However there are some historical evidence, which have shown that slab on grade are discarded, this is because 1. Voids are formed under slab on grade which degrades its stiffness and 2. Basements are built for accommodating the utilities services. On the other hand, the ground floor is a cost effective solution for stringent vibration control<sup>2</sup>. However it is not possible to have a multilevel fab with one or two levels of basement with a resonance frequency significantly above 6 Hz<sup>7</sup>.

Suspended slab may be flat, waffle or beam supported slab which are supported by grid of columns. In past, waffle slabs were successfully used for longer span bays as they have relatively high mass and stiffness. The waffle slab has the intrinsic merits to resist the inertia forces developed by the production tools and hence the vibration interaction among the various plants<sup>8</sup> and then horizontal vibration<sup>9</sup> will also be reduced. It can be seen that the most

economical approach to the low sensitive problem is the waffle slab<sup>10</sup>. However the entire building design for worst case scenario is not a cost effective solution<sup>4</sup>. In this case, the building has to be divided into compartments; however it has a disadvantage when rapid changes take place in tools and production lines due to the technology advancement<sup>4</sup>.

Foundation design for vibration control is taken in to account for designing against the ground borne vibration. The foundation can be pile, raft and pad footing. The type of foundation will vary according to the load and the type of soil. However, the types of intercepting vibration waves will also influencing the type of foundation selected. Stiff foundation such as pile or thick mat foundation is good enough to mitigate the micro vibration<sup>11,12</sup>. On the other hand, the excessive site vibration may be effectively controlled by stiff foundation supported on bedrock<sup>5</sup>.

After constructing the facility, it may be used by production machinery as well as utilities services such as air conditioner duct, power generator, exhaust fan and lift. Some utilities (cooling fan) can not be kept away from sensitive instrument. The area near the edge of the floor and away from passage is preferred to locate sensitive equipment<sup>13</sup>. However, envelope of the building is subject to high background noise and wind-induced vibrations so it has to be keep away from outer perimeter of the floor<sup>6</sup>. The long straight corridors have to be avoided near to sensitive equipment<sup>13</sup>. If similar plants are installed next to each other, they may give rise to response at beat frequencies<sup>14</sup>. Therefore, the type of building and its services has to be identified at initial design to find the quietest part of the building site<sup>9</sup>.

### 3 THEORY

Dynamic force exerting on a structure can be analysed by using equation (3.1). This equation is only valid for linear elastic behaviour of the structure. However, at any given time, it can be applied for dynamic equilibrium of the structure and for low level response, linear range can be assumed.

$$[M]\{\ddot{x}\} + [C]\{\dot{x}\} + [K]\{x\} = \{f\} \quad (3.1)$$

where  $[M]$ ,  $[C]$ ,  $[K]$ ,  $\{f\}$ ,  $\{\ddot{x}\}$ ,  $\{\dot{x}\}$  and  $\{x\}$  are the global mass, damping, and stiffness matrices, force, acceleration, velocity and displacement vectors of the system, respectively.

When, the equation (3.1) is used for base excitation, it is given by:

$$[M][\ddot{v}] + [C][\dot{v}] + [K][v] = -[M][\ddot{x}_g] \quad (3.2)$$

Where  $v$ ,  $\ddot{x}_g$  are relative displacement and ground acceleration respectively. The relative displacement can be calculated as follows.

$$v = x_g - x \quad (3.3)$$

Where  $x_g$  and  $x$  are ground and absolute displacement respectively. The solution of equation (3.3) can be found by transient analysis or mode superposition theory. Furthermore,  $C$  can be derived in terms of mass and stiffness, which is given by equation (3.4)

$$(C) = \alpha(M) + \beta(K) \quad (3.4)$$

where  $\alpha$  and  $\beta$  are Rayleigh coefficients which is related to damping ratio,  $\zeta$  as shown in equation (3.5)

$$\xi = \frac{\alpha}{2\omega} + \frac{\beta\omega}{2} \quad (3.5)$$

Where,  $\omega$  is angular frequency

## 4 MODELLING

### 4.1 Description of Building

The modelled structure represents a fabrication plant which is a three operational storey building. It is a concrete structure. The superstructure of the building is supported by end pile foundation (resting on bed rock). The Pile diameter is 0.600m and they are arranged with distance of 6.9 m and 4.2m from the centres in the X and Z direction respectively. The grid columns are arranged in the spacing of 13.8 m in the 8 bays and 8.4 m in the 6 bays of the building. The minimum and maximum head room are allowed as 6.0 m and 7.5 m respectively. It is important to note that the non structural elements (Partition walls) are not taken into account. The sizes of structural elements and type of floors have not been decided at initial stages.

The stringent condition on the ground floor has to be maintained below vibration criterion [VC] - C. The minimum level of VC-B has to be kept at first floor as well as second floor. The whole structure is being evaluated against a micro tremor interception to achieve our task.

### 4.2 Preliminary Finite Element Model

The hypothetical structure consists of three levels excluding roof structure. Slab panels on the upper floors are spans of 13.8 m x 8.4 m. Those panels have been recommended as waffle slab as they are long span panel. The ground floor slab panels are being decided as flat suspension slab with a dimension of 6.9 m x 4.2 m. Those panels are supported by capping beams on piles. All beam to beam and beam to column connections have been assumed to be rigid as those are constructed by insitu- concrete. The model with rigid connection was generally in agreement with the field counter measurements<sup>9, 15</sup>.

As the real structure has never been analysed by the finite element method, engineering judgements have been used to simplify the whole structure. The column and beam size and waffle slab thickness were initially decided as usual conventional theory without the concern of vibration serviceability.

The structural materials used here are concrete and steel reinforcement. The contributions of steel reinforcement are neglected in this dynamic response analysis. Dynamic modulus of elasticity of concrete was taken as 38 GPa. The concrete density was assumed to be 2400 kg/m<sup>3</sup>. Poisson ratio for concrete was assumed to be 0.2.

The waffle slab was modelled as plate elements according to Szilard's recommendations<sup>16</sup>. When the waffle slab is converted to equivalent plate thickness, it may lead to mass variation from actual condition. The artificial density content of plate was calculated by equalising the mass of the waffle slab and counter part of plate section where the mass is an important parameter in dynamic analysis. The equivalent thickness of plate element and its density were calculated. The equivalent thickness of plate element and its density was calculated as 0.427 m and 1518.8 Kg/ m<sup>3</sup>. The plate element was modelled using ANSYS SHELL 63. Primary beams, capping beams and columns were modelled using ANSYS BEAM 4 element. The ANSYS COMBIN 14 was used to model the piles.

### **4.3 Finite Element Analysis with ANSYS**

The developed finite element was then used to do modal analysis and transient analysis. Modal analysis was carried out for the first forty modes to determine the natural frequencies and the mode shapes of the structure. High number of modes are usual for high frequency floor. Block Lanczos mode extraction method was used in this modal analysis. It has features, which will be able to assign more than forty modes, viable for complex model having various elements and efficient in mode extraction<sup>17</sup>.

Transient analysis was done due to transient nature of loading. There are two methods available to do the transient analysis and they are mode superposition and direct integration method. The direct integration method has a better accuracy than mode super position. Mode superposition method is able to explore real behaviour of structure at each mode. It can lead to identify the participation of each mode in the ultimate dynamic response. For example, the sway mode may not be participating in vertical response at the middle of floor; however it can be confirmed by doing transient analysis for that particular mode.

Transient analysis solution can be done by either reduced or full structure matrices in ANSYS. Reduced method was used to speed up solution. It is viable for linear analysis. The accuracy of the result was checked by increasing integration time step from recommended value of ANSYS and reducing mesh size. No significant differences found.

## **5.0 SENSITIVITY ANALYSIS**

Even though the intended structure has 8 x 6 bays, the three storey building without roof having one bay structure was initially built up by advancing through different combination of bays. Finally a three storey building with 3 x 3 bays was checked for vibration serviceability rather than analysing the whole intended structure. This was done for applicability of critical appraisal.

## 5.1 Modal Analysis

Having set a lower limit of sway frequency as 3 Hz to avoid wind - induced sway, the modal analysis was carried out for the first forty modes to find modal properties of the structure. The greatest interest was laid on sway frequency and the first floor mode frequency, which were recorded for the preliminary model and was found to be 2.178 Hz. The structural parameters were updated to get sway frequency more than 3 Hz.

During updating process, the structures were artificially restrained in X direction. The effect of sway mode in X direction was avoided and the column dimension in Z direction was increased until the sway frequency was more than 3 Hz in Z direction. The optimized column dimensions were identified as 1.175 m in X direction and 1.050 m in Z direction for keeping sway frequency more than 3 Hz. The sway frequency with updated column dimension was obtained at 3.048 Hz. Number of storey was increased for a given column dimensions when the sway frequency was reduced from 3.048 to 2.0218 Hz.

By keeping the preliminary column dimension the same, the modal analysis was done for different thickness plate with span of 13.8 x 8.4 m. The sway frequencies were recorded against the various plate thicknesses. The above modal analysis was again done for floor slab span of 8.4 x 8.4 m. It was interesting to identify that there is no significant difference in sway frequency for varying thickness of a given panel but it was increased by 0.600 Hz with the reduction of panel size.

The modal analysis was again done for updated column dimensions and initial structural parameters of the floor. The first floor mode occurred as the fifth standard mode and natural frequency was identified as 11.698Hz as shown in figure 5.1.

The modal analysis was then done for the structure restraining in X and Z direction at each floor to restrain the low frequency 'rigid body' sway modes. The floor mode then occurred at first step. There was no significant difference in natural frequency of the floor mode and it was recorded as 11.698 Hz. The mode shape of floor mode for sway and non sway structure were similar as shown in Figure 5.1.

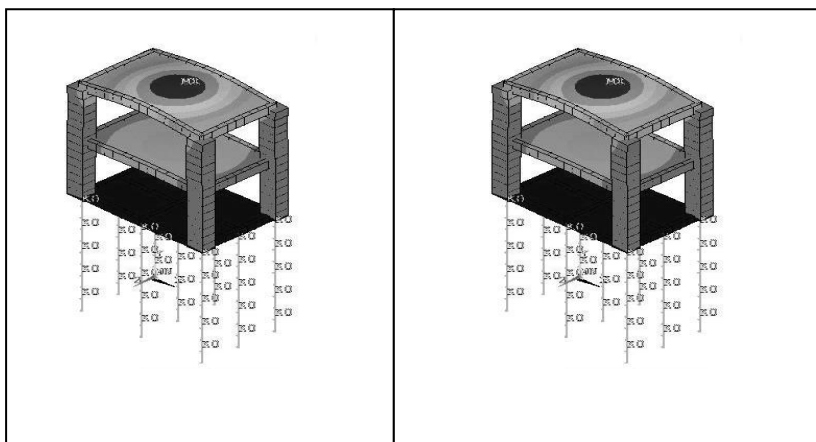

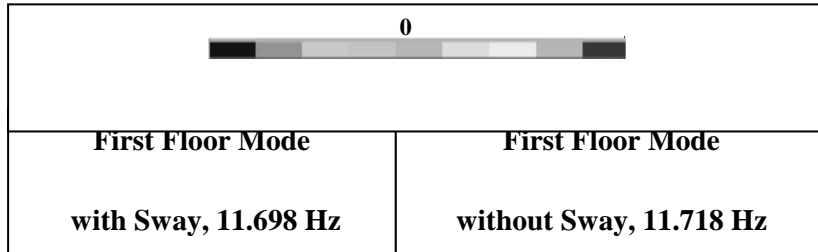

Figure 5.1. Influence of Sway mode in Floor Mode

The number of panels was increased in X –direction and Y-direction for given parameters. It was noticed that the sway frequency was reduced. However, the number of panels was symmetrically increased in both directions and there was no significant difference in the sway frequency.

## 5.2 Transient Analysis

The model was simulated by vertical acceleration field (typical micro tremor). A master degree of freedom was introduced in the direction of ‘Y’ on the middle of the second floor to identify the displacement response.

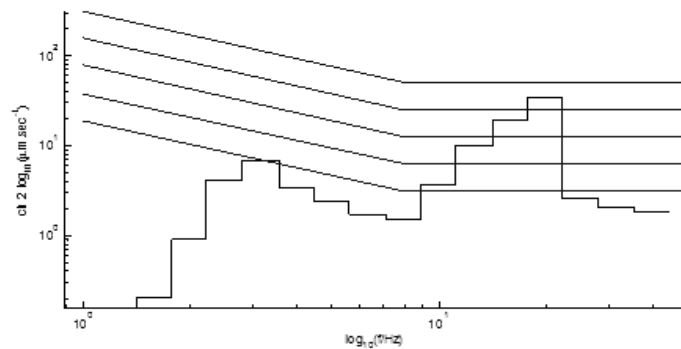

Figure 5.2 Vibration Criterion Curve for Absolute Response

Output data were obtained in every fourth step to add with the ground displacement data to obtain the absolute displacement variation, and then converted to vibration criterion curve, which is shown in Figure 5.2.



Peak displacement response was identified before 3 Hz and in between 10 Hz and 15 Hz. Since the sway frequency of the structure is maintained above 3 Hz, the peak response occurred before the 3 Hz is due to the ground displacement. The peak response in between 10 and 15 Hz is due to the ground acceleration. It occurred exactly at 11.698 Hz, which is the first mode of floor vibration.

The influence of the extra floors on the dynamic response of the current (second) floor was evaluated by changing the number of storeys and keeping the other parameters same. Three, four and seven storey building without the roof was studied. The peak response of the three and four storey building was very similar. However the peak response has moved towards the lower scale of the frequency when the number of storeys increases. In comparison to the other two story buildings, the peak response of the seven storeys has increased and it occurs at even lower frequency.

Compressive axial load has the ability to reduce natural frequencies of the floor. This scenario can be clearly identified when the column stiffness is infinitely increased and hence it acts as a rigid body. Therefore, the dynamic response at the slab can be reduced by reducing the column dimension, but the sway frequency of the structure will be reduced as discussed earlier

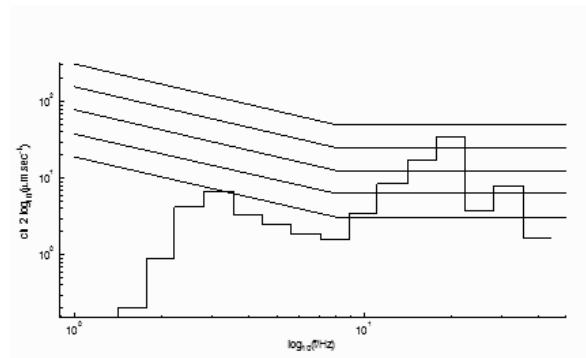

Figure 5.3 Influence of sway mode on dynamic response

The influence of sway modes on floor dynamic response was evaluated for a given structure. Sway mode of the structure was avoided by restraining the x and y direction on the first and second floor. Transient analysis was done by mode superposition method. Dynamic response of the second floor was similar to the sway structure up to the peak response as shown in figure 5.3. The variation after the peak response is because the number of floor mode contribution increases in non sway mode within the defined number of modes (40 modes). Therefore the influence of sway mode can be negligible in the concern of vertical response of the floors.

The effects of bay size on the floor response was analysed by reducing the bay size to 8.4 x 6.0 m. Transient analysis was carried out with the condition of non sway mode even though the sway mode will not significantly affect the floor vibration. The peak response of the middle of the panel was decreased dramatically. It occurred at the higher frequency scale away from Y axis where the natural frequency of the floor has increased. In this situation, slab panel acts as rigid body than column, i.e. slab now stiffer so column has to bend, hence the number of sway

modes occurring has increased before the floor mode appears. Floor mode will occur when the dynamic stiffness of panel is less than the column stiffness. Therefore Dynamic response of panel can be reduced by decreasing the panel size

As floor mode influences the dynamic response, the different combination of bays was analysed. The combination of 1 x 1, 2 x 1, 1x 2 and 3x3 were taken into account. Transient analysis was done with the non sway mode condition. Dynamic responses were taken in the middle of all the panels of the all combinations of panels There is no significant difference in critical response (the peak response increases) of the combinations of 1x1, 2x1 and 1x2. However the middle panel of combination 3x3 showed much higher peak response than other panels. Therefore, this shows that in an evenly distributed column grids, the response is much lower on the locations towards corner of the floor.

By considering the above critical appraisal, the transient analysis was done for 3x3 bays by direct integration method to achieve the vibration serviceability acceptance criteria as specified. Dynamic responses are increased with the number of panels as expected. For understanding the optimization process, the first floor waffle slab parameters are iterated. Equivalent thickness of plate was taken as 0.650 m, 0.813 m and 0.780 m. The same sensitivity control was achieved with various volume of waffle slab. This means that the structural parameters can be optimised to achieve the specified vibration serviceability acceptance criteria.

Having selected the flat suspension slab on the ground floor, a vibration serviceability acceptance criteria was expected as VC-C on the ground floor. More stringent criteria than VC-C was achieved with the slab thickness of 0.250 m. However when the thickness was iterated to optimize thickness of slab, there was no significant difference in the VC curve In the structural requirements it becomes an issue when the slab thickness is below the thickness of 0.175 m. Therefore the ground floor slab supporting by very stiff foundation is not always critical to achieve the vibration requirement. It was identified that the peak response was occurred due to ground displacement.

## **6.0 CONCLUSIONS**

A finite element model was developed for a specific building to study the dynamic response due to the micro tremor excitation to provide a good design for low rise sensitive facilities. The developed model has automatic updating facilities to change the variables like building dimensions, structural parameters, dynamic loading and type of analysis. Only the modern finite element software like ANSYS has a coding facility which would allow automatic updating of these parameters where a quick evaluation of sensitivity can be carried out. The comparison of the dynamic response with different structural parameters and an investigation of the modes of the structure enabled to evaluate the following conclusions:

1. The unsymmetrical extension of the building may lead to lower level of overall sway frequency. The extension of fabrication plant buildings has to be symmetrical to maintain a same order of sway frequency.

2. The contribution of sway mode in vertical response of the floor can be neglected. However, the sway frequency will affect the dynamic response of the floor, where the dynamic response of the floor increases with sway frequency for a given structure. Nevertheless the sway frequency reduces by increasing the number of storeys, which would lead to an increase in the dynamic floor response.
3. The high frequency floor is not only dependant on the structural parameters of the floor; however, it is also dependant on the stiffness of the supporting member and the connections between the floors and the supporting members.
4. The low rise sensitive facility building divided into different compartments by structural isolation is a useful method to reduce the critical displacement of each operating floors. The sensitive equipment housing on the corner panel of the floor is a very conservative approach as the dynamic response is very low.
5. Vibration control may not be critical for a specific vibration serviceability acceptance criteria on the ground floor as it is supported by a stiff foundation. The dynamic response due to the ground displacement without any effect of the building is the governing factor on the ground floor than the ground acceleration.

## References

1. Amick H, *On generic vibration criteria for advanced technology facilities*. Journal of the Institute of Environmental Sciences, Vol. XL, No.5, p 35-44, 1997.
2. Yazdanniyaz A, Carlson A, Bui S, Wenger C, and Lalime A, *Design of vibration-sensitive laboratory floors: Vibration criteria and prediction methods compared with measured vibration*. The Architectural Engineering Conference, Austin, Texas, USA, 2003.
3. Bayat A, and Davis J.B, *Converting semiconductor fabs: The vibration design perspective*. Journal of the IEST, Vol.48, p 161-168, 2005.
4. Anderson R, *Design for vibration control in microelectronics facilities*. Proceeding of International Conference on Vibration Control in Microelectronics, Optics, and Metrology, San Jose, CA, USA, SPIE Vol. 1619, 161, 1991.
5. Gordon C.G, *The design of low-vibration building for microelectronics and other occupancies*. Proceeding of first International conference on Vibration Control in Microelectronics, Optics, and Metrology, SPIE Vol.732, London, UK, 1987.
6. Chin-Quee D, *Vibration considerations in laboratories*. Technotes of Consulting Engineers and Scientists, Issue No.14.
7. Amick H and Kim J.J, *Active Vibration Control in Fabs*. Proceeding of Semiconductor International, July, 1997.
8. Howard C.Q, and Hansen.C.H, *Vibration analysis of waffle floors*. In: Computers and Structures publication, Vol.81, p 15-26, 2003.
9. Tang N, Wu C, Xiong B, Gendreau M, Amick H, Yin S.Y, and Wu T, *Dynamic features of precast waffle slabs in cleanroom design*. Proceeding of a conference and exposition on structural dynamics by Society for Experimental Mechanics, Orlando, Florida, USA, 2007.

10. Amick H, Hardash S, Gillett P, and Reaveley R.J, *Design of stiff, low-vibration floor structures*. Proceeding of International Society for Optical Engineering, San Diego, California, USA, pp.180-191, 1991.
11. Brownjohn J, and Pavic A, *Vibration control of ultra-sensitive facilities*. Proceedings of the Institution of Civil Engineers, Structures and Buildings, No 159, p 295-306, 2006.
12. Hwang J.S, ASCE M, Huang Y.N, Hung Y.H, and Huang J.C *Applicability of Seismic Protective Systems to Structures with Vibration-Sensitive Equipment*. Journal of Structural Engineering, Vol.130, No 11, 2004.
13. UNGAR E.E., STURZ D.H, and AMICK H, *Vibration control design of high technology facilities*. Sound and Vibration, 1990, 24, No.7, 20-27.
14. Hertlein B.H, *Designing and building to 'IMPOSSIBLE' tolerances for vibration sensitive equipment*. Proceeding of American Institute of Physics conference, USA, Vol. 657, pp .1209-1218, 2003.
15. Pavic A, Miskovic Z, and Reynolds P, *Modal testing and finite-element modal updating of a lively open-plan composite building floor*. Journal of Structural Engineering, p550-558, 2007.
16. Szilard R, *Theories and Applications of Plate Analysis*. 1<sup>st</sup> Edition, John Wiley & Sons, 2004.
17. ANSYS 10.0 Reference Manual.